

Display Elektronik GmbH

DATA SHEET

TFT MODULE

**DEM 800480E TMH-PW-N
(C2-TOUCH)**

5.0“ TFT + PCT

Product Specification

Ver.: 0

06.03.2019

Revise Records

Rev.	Date	Contents	Written	Approved
0	06.03.2019	Preliminary Specification	J	MHI

Special Notes

Note1.	
Note2.	
Note3.	
Note4.	
Note5.	

Contents

1. General Description and Features	4
1.1. Features	4
1.2. LCD Module	4
2. Mechanical Information	4
3. Electrical Specifications	5
3.1. Absolute Max. Ratings	5
3.2. AC Timing Characteristic of The LCD	8
3.3. Back-Light Unit	10
4. Optical Characteristics	11
4.1. Optical characteristic of the LCD	11
5. I/O Terminal	13
5.1. Pin Assignment	13
5.2. Block Diagram	15
6. Displayed Color and Input Data	16
7. Projected capacitive touch Screen Panel Specifications	17
7.1. Power Supply	17
7.2. DC Characteristics	17
7.3. Pin Assignments and Definitions.	17
7.4. FUNCTIONAL DESCRIPTION	18
8. Reliability Condition	18
9. Dimensional Outlines	20
10. Incoming Inspection Standards	21

1. General Description and Features

DEM 800480E TMH-PW-N (C2-TOUCH) is a transmissive type color active matrix TFT (Thin Film Transistor) liquid crystal display (LCD) that uses amorphous silicon TFT as a switching device. This model is composed of a TFT-LCD module, a driver circuit, projected capacitive touch panel and a back-light unit. Graphics and texts can be displayed on a WVGA 800 (W) x 3 x 480 (H) dots (15:9 aspect ratio) with 16.7M colors by supplying 24 bits data signal (8 bits/each color). The following table described the features of DEM 800480E TMH-PW-N (C2-TOUCH).

1.1 Features

- Transmissive and Backlight with 14 LEDs are available.
- TN (Twisted Nematic) mode.
- Digital RGB (8 bits/color) Data Transfer.
- Data enable mode.
- Projected Capacitive Touch Panel
- ROHS Compliance

1.2 LCD Module

Item	Specification	Unit
Screen Size	5.0 Inches	Diagonal
Display Resolution	800 x 480	Pixel
Active Area	108.00 x 64.80	mm
Outline Dimension	118.50 x 77.55 x 5.73	mm
Display Mode	Normally White Mode / Transmissive	--
Pixel Arrangement	R,G,B Vertical Stripe	--
Pixel Size	0.1350 x 0.1350	mm
Display Color	16.7 Million	--
Viewing Direction	6 o'clock (Gray inversion)	--
Input Interface	Digital RGB (8 bits/color) Data Transfer	--

2. Mechanical Information

Item		Min.	Typ.	Max.	Unit	Note
Module Size	Horizontal (H)	118.2	118.5	118.8	mm	
	Vertical (V)	77.25	77.55	77.85	mm	
	Thickness (T)	5.43	5.73	6.03	mm	(1)
Weight		--	(TBD)	--	g	--

Note (1) Not Include Component . Refer to the Outline Dimension Drawing as attached.

3. Electrical Specifications**3.1 Absolute Max. Ratings****3.1.1 Absolute Ratings of Environment**

If the operating condition exceeds the following absolute maximum ratings, the TFT LCD module may be damaged permanently.

($T_a=25\pm 2^\circ\text{C}$, $V_{SS}=\text{GND}=0$)

Item	Symbol	Min.	Max.	Unit	Note
Storage Temperature	T_{STG}	-30	80	°C	(1)
Operating Temperature	T_{OPR}	-20	70	°C	(1,2,3)

Note (1) 95 % RH Max. ($40^\circ\text{C} \geq T_a$). Maximum wet-bulb temperature at 39°C or less. ($T_a > 40^\circ\text{C}$) No condensation.

Note (2) In case of below 0° , the response time of liquid crystal (LC) becomes slower and the color of panel becomes darker than normal one. Level of retardation depends on temperature, because of LC's character

Note (3) Only operation is guaranteed at operating temperature. Contrast, response time, another display quality are evaluated at $+25^\circ\text{C}$.

3.1.2 Electrical Absolute Maximum Ratings

(V_{SS}=GND=0)

Parameter	Symbol	Min.	Max.	Unit	Remark
Power Supply Voltage	V _{DD}	-0.5	5.0	V	
Signal Input Voltage	R0-R7,G0-G7, B0-B7,DCLK,DE,HS,VS	-0.3	V _{DD} +0.3	V	--
Permissive Input Ripple Voltage	V _{RF}	--	100	mVp-p	V _{DD} = +3.3V

Display On/Off Sequence :

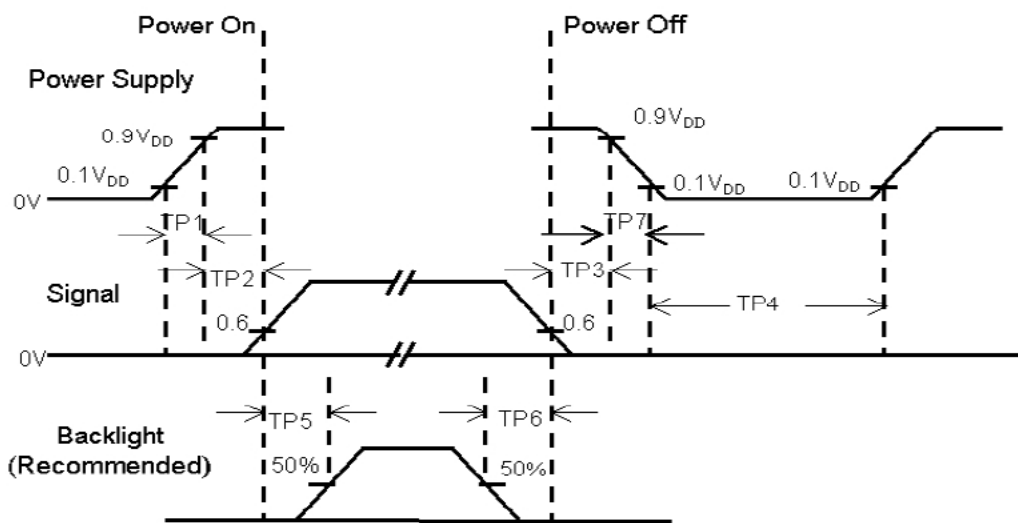

Note :

- (1) The supply voltage of the external system for the module input should be the same as the definition of V_{DD}.
- (2) Apply the lamp voltage within the LCD operation range. When the back-light turns on before the LCD operation or the LCD turns off before the back-light turns off, the display may momentarily become white.
- (3) In case of V_{DD} = off level, please keep the level of input signal on the low or keep a high impedance.
- (4) TP4 should be measured after the module has been fully discharged between power off and on period.
- (5) Interface signal shall not be kept at high impedance when the power is on.

3.1.3 DC Electrical Characteristics of the TFT LCD

(Ta=25±2°C, Vss=GND=0)

Item	Symbol	Min.	Typ.	Max.	Unit	Remark
Power Supply	VDD	3.0	3.3	3.6	V	
Input Voltage for logic	H Level	0.7xVDD	-	VDD	V	
	L Level	0	-	0.3xVDD	V	
Power Supply Current	IDD	-	(220)	(250)	mA	Note 1

Note1: fv =60Hz , Ta=25°C , Display pattern : Black pattern

Black Pattern / 0 Gray

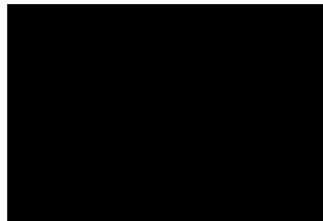

Active Area

3.2 AC Timing Characteristic of The LCD

3.2.1 Timing Condition (DE only mode)

Signal	Parameter	Symbol	Min.	Typ.	Max.	Unit.	Remark
DCLK	DCLK Cycle Time	T_{cph}	25	-	-	ns	
	DCLK Frequency	f_{clk}	-	30	40	MHz	
	DCLK High Plus Width	T_{cwh}	40	50	60	%	
Horizontal	HSD Setup Time	T_{hst}	8	-	-	ns	
	HSD Hold Time	T_{hhd}	8	-	-	ns	
	Horizontal Display Area	t_{hd}	-	800	-	Tcph	
	HSD Period Time	t_h	-	928	-	Tcph	
	HSD Pulse Width	t_{hpw}	1	48	-	Tcph	
	HSD Back Porch	t_{hb}	-	40	-	Tcph	
	HSD Front Porch	t_{hfp}	-	40	-	Tcph	
Vertical	VSD Setup Time	T_{vst}	8	-	-	ns	
	VSD Hold Time	T_{vhd}	8	-	-	ns	
	Vertical Display Area	t_{vd}	-	480	-	th	
	VSD Period Time	t_v	-	525	-	th	
	VSD Pulse Width	t_{vpw}	-	3	-	th	
	VSD Back Porch	t_{vb}	-	29	-	th	
	VSD Front Porch	t_{vfp}	-	13	-	th	
DE	DE Setup Time	T_{esu}	8	-	-	ns	
	DE Hold Time	T_{ehd}	8	-	-	ns	
DATA	Data Setup Time	T_{dsu}	8	-	-	ns	
	Data Hold Time	T_{dhd}	8	-	-	ns	

3.2.2 Timing Characteristic

3.2.2.1 DE and RGB Input Timing

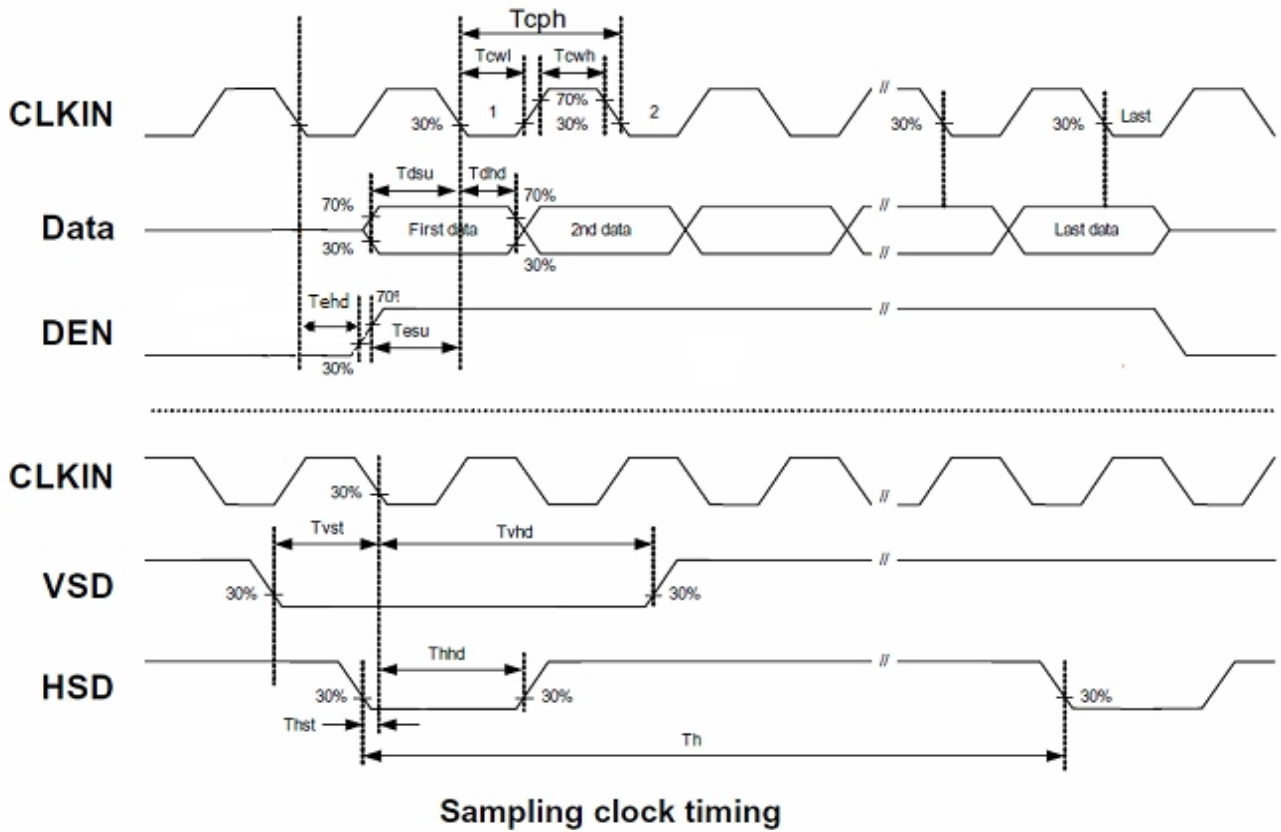

Sampling clock timing

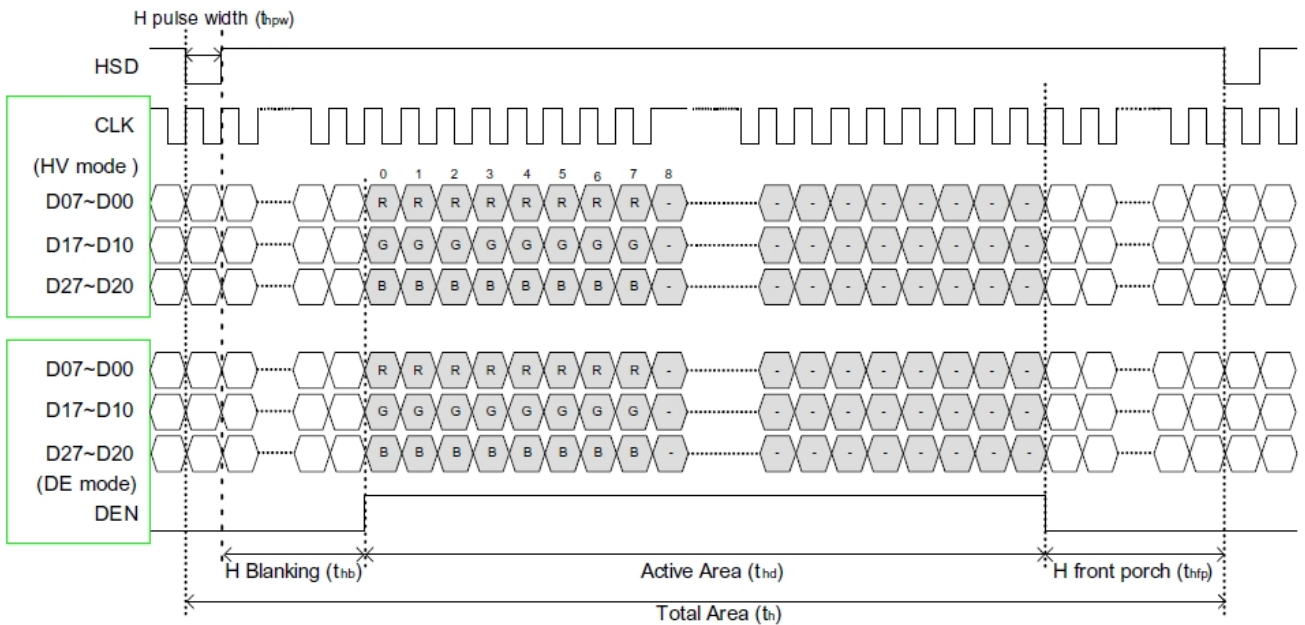

Horizontal display timing range

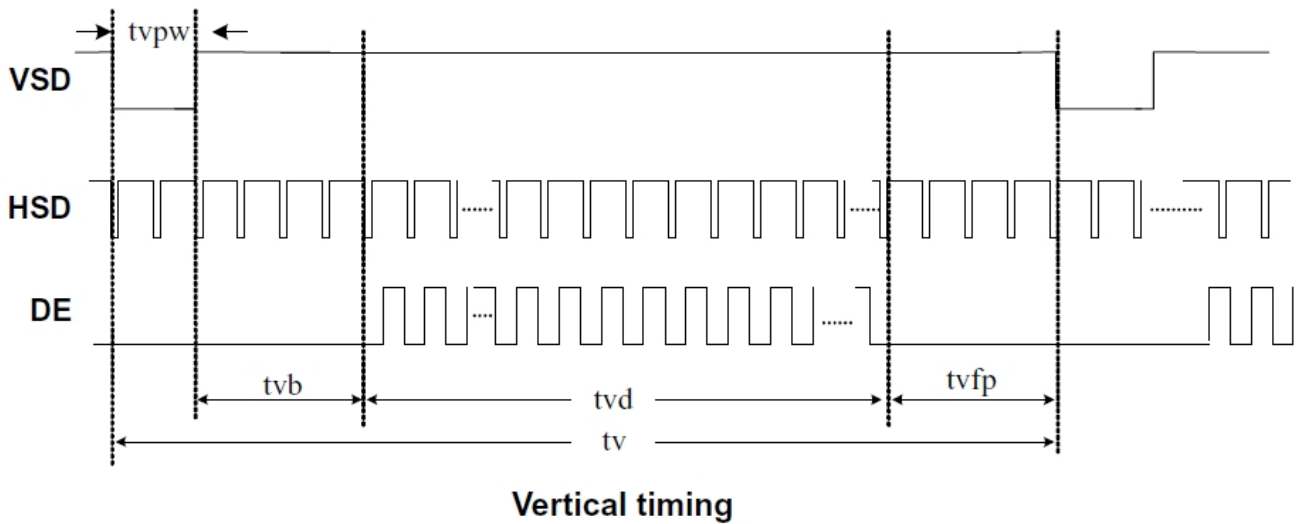

3.3 Backlight Unit

The Back-light system is an edge-lighting type with 14 white LEDs (Light Emitting Diode). The characteristics of 14 white LEDs are shown in the following tables.

(Ta= Room Temp)

Characteristics	Symbol	Min.	Typ.	Max.	Unit	Note
Forward Voltage	V_f	21	23.1	23.8	V	
Forward Current	I_f	-	40	50	mA	(1)
Power Consumption	P_{BL}	-	924	1190	mW	(2)
LED Lifetime	-	50000	-	-	hr	(3)

Note (1) LEDs in 7 series x 2 parallel type.

(2) Where $I_f = 40\text{mA}$, $V_f = 23.1$, $P_{BL} = V_f \times I_f$

(3) The environmental conducted under ambient air flow, at $T_a = 25 \pm 2^\circ\text{C}$, $60\%RH \pm 5\%$

4. Optical Characteristics

4.1 Optical characteristic of the LCD

The following items are measured under stable conditions. The optical characteristics should be measured in a dark room or equivalent state with the methods.

Measuring equipment: BM-7A

Item	Symbol	Condition	Min	Type	Max	Unit	Note	
Brightness	B		330	420	--	cd/m ²		
Response Time	T _r	θ=0°	-	3	6	ms	.	
	T _f		--	7	14	ms		
Contrast Ratio	CR	At optimized viewing angle	480	600	--	--		
Luminance Uniformity	ΔL		70	80		%		
Color Chromaticity (CIE 1931)	White	W _x	θ=0° Normal Viewing Angle	0.277	0.307	0.337	--	BM-7A
		W _y		0.318	0.348	0.378		
Viewing Angle (6H)	Hor.	θ _R	CR≥10	65	75	--	Degree	
		θ _L		65	75	--		
	Ver.	θ _U		50	60	--		
		θ _D		60	70	--		

a. Test equipment setup

After stabilizing and leaving the panel alone shall be warmed up for the stable operation of LCM, the measurement should be executed. Measurement should be executed in a stable, windless, and dark room. Optical specifications are measured by Topcon BM-7(fast) with a viewing angle of 2° at a distance of 50cm and normal direction.

b. Definition of response time: Tr and Tf

The response time is defined as the following figure and shall be measured by switching the input signal for "black" and "white".

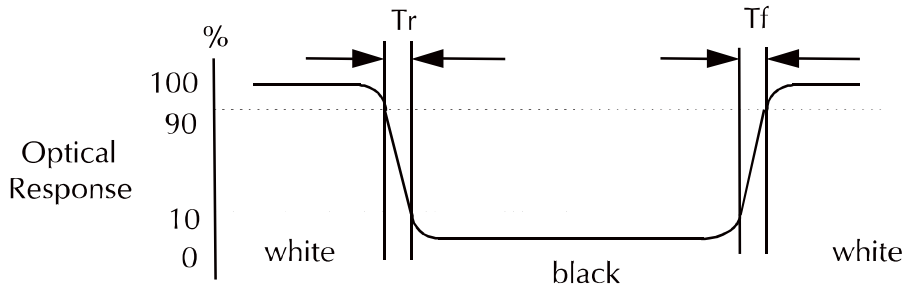

c. Definition of contrast ratio:

$$\text{Contrast Ratio (CR)} = \frac{\text{Brightness measured when LCD is at "white state"}}{\text{Brightness measured when LCD is at "black state"}}$$

d. Measured at the center area of the panel when all the input terminals of LCD panel are electrically opened.

e. View Angle

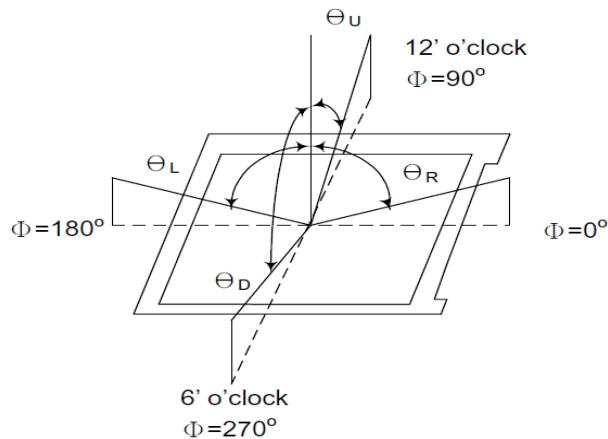

f. Definition of Luminance of White: Luminance of white at the center points

Light Source of Back-Light Unit	LED Type
---------------------------------	----------

g. Definition of White Uniformity

$$\text{White Uniformity} = \frac{\text{Min. luminance of white among 9-points}}{\text{Max. luminance of white among 9-points}} \times 100\%$$

h. The definition of Color Gamut -Color Chromaticity CIE 1931

Color coordinate of white & red, green, blue at center point.

Color Gamut : NTSC(%) = (RGB Triangle Area / NTSC Triangle Area) x 100

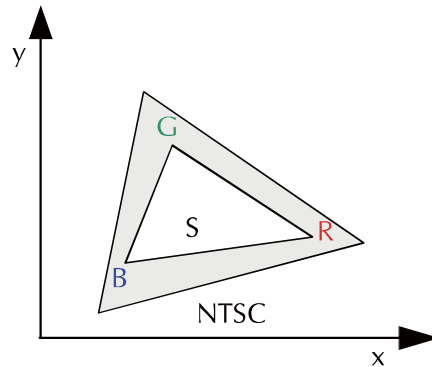

5. I/O Terminal

5.1 Pin Assignment

Pin No.	Symbol	I/O	Function	Remark
1	VLED-	P	Power for LED backlight cathode	
2	VLED+	P	Power for LED backlight anode	
3	GND	P	Power Ground	
4	VDD	P	Power Supply	
5	R0	I	Red data signal (LSB)	
6	R1	I	Red data signal	
7	R2	I	Red data signal	

8	R3	I	Red data signal	
9	R4	I	Red data signal	
10	R5	I	Red data signal	
11	R6	I	Red data signal	
12	R7	I	Red data signal (MSB)	
13	G0	I	Green data signal (LSB)	
14	G1	I	Green data signal	
15	G2	I	Green data signal	
16	G3	I	Green data signal	
17	G4	I	Green data signal	
18	G5	I	Green data signal	
19	G6	I	Green data signal	
20	G7	I	Green data signal (MSB)	
21	B0	I	Blue data signal (LSB)	
22	B1	I	Blue data signal	
23	B2	I	Blue data signal	
24	B3	I	Blue data signal	
25	B4	I	Blue data signal	
26	B5	I	Blue data signal	
27	B6	I	Blue data signal	
28	B7	I	Blue data signal (MSB)	
29	DGND	P	Digital ground	
30	DCLK	I	Pixel clock	
31	DISP	I	Display on/ off	
32	HSYNC	I	Horizontal sync signal	
33	VSYNC	I	Vertical sync signal	
34	DE	I	Data Enable signal	
35	NC	I	No Connect	
36	GND	P	Power Ground	
37	NC	-	No connect	
38	NC	-	No connect	
39	NC	-	No connect	
40	NC	-	No connect	

I: Input, O: Output, P: Power

Notes:

- 1) NC Pin must be retained; this pin can't contact GND or other signal.
- 2) GND Pin must ground contact, can not be floating.
- 3) Connector Part No: FH12A-40S-0.5SH (55)or equivalent.

5.2 Block Diagram

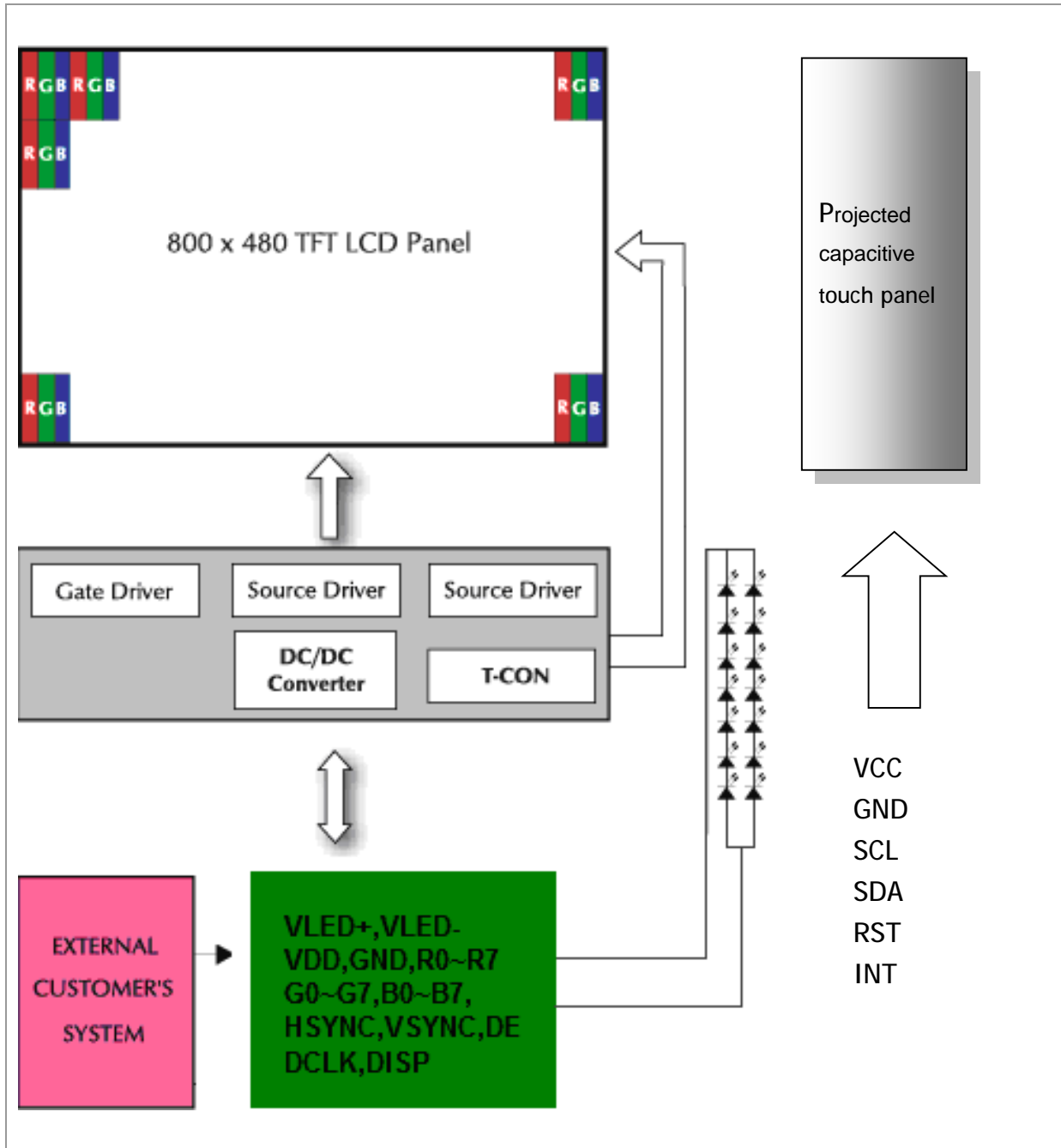

6. Displayed Color and Input Data

	Color & Gray Scale	Data Signal																							
		R7	R6	R5	R4	R3	R2	R1	R0	G7	G6	G5	G4	G3	G2	G1	G0	B7	B6	B5	B4	B3	B2	B1	B0
Basic Color	Black	0	0	0	0	0	0	0	0	0	0	0	0	0	0	0	0	0	0	0	0	0	0	0	
	Red	1	1	1	1	1	1	1	1	0	0	0	0	0	0	0	0	0	0	0	0	0	0	0	
	Green	0	0	0	0	0	0	0	0	1	1	1	1	1	1	1	1	0	0	0	0	0	0	0	
	Blue	0	0	0	0	0	0	0	0	0	0	0	0	0	0	0	0	1	1	1	1	1	1	1	
	Cyan	0	0	0	0	0	0	0	0	1	1	1	1	1	1	1	1	1	1	1	1	1	1	1	
	Magenta	1	1	1	1	1	1	1	1	0	0	0	0	0	0	0	0	1	1	1	1	1	1	1	
	Yellow	1	1	1	1	1	1	1	1	1	1	1	1	1	1	1	1	0	0	0	0	0	0	0	
	White	1	1	1	1	1	1	1	1	1	1	1	1	1	1	1	1	1	1	1	1	1	1	1	
Red	Black	0	0	0	0	0	0	0	0	0	0	0	0	0	0	0	0	0	0	0	0	0	0		
	Red(1)	0	0	0	0	0	0	0	1	0	0	0	0	0	0	0	0	0	0	0	0	0	0		
	Red(2)	0	0	0	0	0	0	1	0	0	0	0	0	0	0	0	0	0	0	0	0	0	0		
	:	:	:	:	:	:	:	:	:	:	:	:	:	:	:	:	:	:	:	:	:	:	:		
	Red(127)	0	1	1	1	1	1	1	1	0	0	0	0	0	0	0	0	0	0	0	0	0	0		
	:	:	:	:	:	:	:	:	:	:	:	:	:	:	:	:	:	:	:	:	:	:	:		
	Red(254)	1	1	1	1	1	1	1	0	0	0	0	0	0	0	0	0	0	0	0	0	0	0		
	Red(255)	1	1	1	1	1	1	1	1	0	0	0	0	0	0	0	0	0	0	0	0	0	0		
Green	Black	0	0	0	0	0	0	0	0	0	0	0	0	0	0	0	0	0	0	0	0	0	0		
	Green(1)	0	0	0	0	0	0	0	0	0	0	0	0	0	0	1	0	0	0	0	0	0	0		
	Green(2)	0	0	0	0	0	0	0	0	0	0	0	0	0	1	0	0	0	0	0	0	0	0		
	:	:	:	:	:	:	:	:	:	:	:	:	:	:	:	:	:	:	:	:	:	:	:		
	Green(127)	0	0	0	0	0	0	0	0	0	1	1	1	1	1	1	1	0	0	0	0	0	0		
	:	:	:	:	:	:	:	:	:	:	:	:	:	:	:	:	:	:	:	:	:	:	:		
	Green(254)	0	0	0	0	0	0	0	0	1	1	1	1	1	1	1	0	0	0	0	0	0	0		
	Green(255)	0	0	0	0	0	0	0	0	1	1	1	1	1	1	1	0	0	0	0	0	0	0		
Blue	Black	0	0	0	0	0	0	0	0	0	0	0	0	0	0	0	0	0	0	0	0	0	0		
	Blue(1)	0	0	0	0	0	0	0	0	0	0	0	0	0	0	0	0	0	0	0	0	0	1		
	Blue(2)	0	0	0	0	0	0	0	0	0	0	0	0	0	0	0	0	0	0	0	0	0	1		
	:	:	:	:	:	:	:	:	:	:	:	:	:	:	:	:	:	:	:	:	:	:	:		
	Blue(127)	0	0	0	0	0	0	0	0	0	0	0	0	0	0	0	0	1	1	1	1	1	1		
	:	:	:	:	:	:	:	:	:	:	:	:	:	:	:	:	:	:	:	:	:	:	:		
	Blue(254)	0	0	0	0	0	0	0	0	0	0	0	0	0	0	0	1	1	1	1	1	1	0		
	Blue(255)	0	0	0	0	0	0	0	0	0	0	0	0	0	0	0	1	1	1	1	1	1	1		

0 : Low level voltage, 1 :High level voltage

Each basic color can be displayed in 256 gray scales from 8 bit data signals. With the combination of total 24 bit data signals, the 16.7M color display can be achieved on the screen.

7. Projected capacitive touch Screen Panel Specifications

7.1 Features

Item	Specification	Unit
Screen Size	5.0 Inches	Diagonal
Type	Transparent Type Projected Capacitive Touch Panel	--
Input Mode	Human's Finger	--
Sensor Active Area	108.00 x 64.80	mm
Interface	I2C	--
Cover Glass Pencil-Handness	6H(min) by JIS K5400	--
Digital Power Supply	3.3	V
Power Consumption	TBD	mA
IC solution	IC : ILI2117A	

7.2 Electrical Characteristics

1. Power Supply

Item	Symbol	Min	Typ.	Max	Unit
System power supply voltage	VDD	2.8		3.3	V
Ambient operating temperature	T _A	-40		85	°C
Junction Temperature	T _J			125	°C

2. DC Characteristics

Item	Symbol	Min	Typ.	Max	Unit
Input Voltage, High 1	(V _{IH1}) ¹	1			V
Input Voltage, High 2	(V _{IH2}) ²	1.3			V
Input Voltage, Low	(V _{IL})			0.5	V
Output Voltage, High 1	(V _{OH1}) ³		See Note3		V
Output Voltage, High 2	(V _{OH2}) ⁴	V _{VDD} - 0.1			V
Output Voltage, Low	(V _{OL})			0.1	V

Specifications are subjected to change without notice.

Notes:

1. V_{IH1} includes pins CHIP_EN, SDA, SCL, INT
2. V_{IH2} includes pin EXT_CLK
3. V_{OH1} is for INT output voltage level which is programmable by registers. Typical values are 1.2V/1.5V/1.8V/V_{VDD}.
4. V_{OH2} refers to other digital pins.

7.3 Pin Assignments and Definitions.

Item	Name	I/O	Unit
1	VCC	P	Power supply 3.3V
2	SCL	I	I2C Clock
3	SDA	I/O	I2C Data
4	INT	I	Interrupt request to the host
5	RST	I	External Reset, active low
6	GND	P	Ground

7.4 FUNCTIONAL DESCRIPTION

7.4.1 AC Characteristics of the SDA and SCL on I2C interface

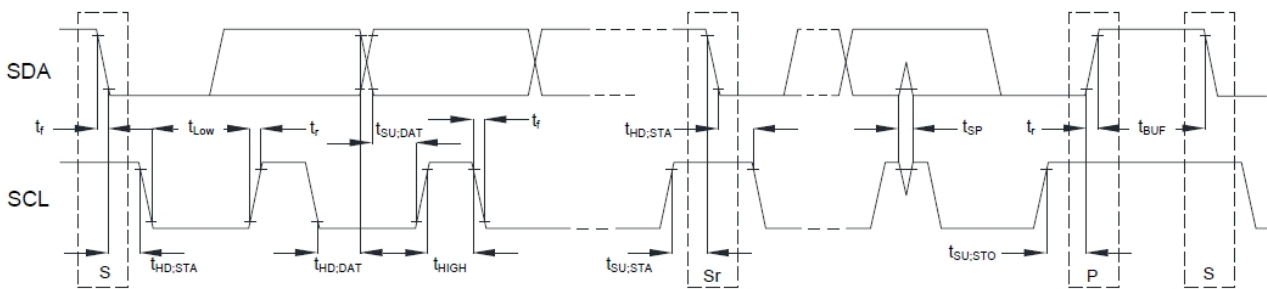

The timing of I2C Interface

Symbol	Parameter	100KHz			400KHz		
		Min	Max	Unit	Min	Max	Unit
f_{SCL}	SCL clock frequency	0	100	KHz	0	400	KHz
$t_{HD:STA}$	Hold time (repeated) START condition. After this period, the first clock pulse is generated	4.0	-	μs	0.6	-	μs
t_{LOW}	LOW period of the SCL clock	4.7	-	μs	1.3	-	μs
t_{HIGH}	HIGH period of the SCL clock	4.0	-	μs	0.6	-	μs
$t_{SU:STA}$	Set-up time for a repeated START condition	4.7	-	μs	0.6	-	μs
$t_{HD:DAT}$	Data hold time	0	3.45	μs	0	0.9	μs
$t_{SU:DAT}$	Data set-up time	250	-	ns	100	-	ns
t_r	Rise time of both SDA and SCL signals	-	1000	ns	-	300	ns
t_f	Fall time of both SDA and SCL signals	-	300	ns	-	300	ns
$t_{SU:STO}$	Set-up time for STOP condition	4.0	-	μs	0.6	-	μs
t_{BUF}	Bus free time between a STOP and START condition	4.7	-	μs	1.3	-	μs

8 Reliability Condition

No change on display and in operation under the following test condition.

Condition: Unless otherwise specified, tests will be conducted under the following condition.

Temperature: $20 \pm 5^\circ C$.

Humidity: $65 \pm 5\% RH$.

Tests will be not conducted under functioning state.

No.	Parameter	Condition	Notes
1	High Temperature Operating	$70^\circ C \pm 2^\circ C$, 240hrs (Operation state).	
2	Low Temperature Operating	$-20^\circ C \pm 2^\circ C$, 240hrs (Operation state).	1
3	High Temperature Storage	$80^\circ C \pm 2^\circ C$, 240hrs.	2
4	Low Temperature Storage	$-30^\circ C \pm 2^\circ C$, 240hrs.	1,2
5	High Temperature and High Humidity Operation Test	$60^\circ C \pm 2^\circ C$, 90%, 240hrs.	1,2

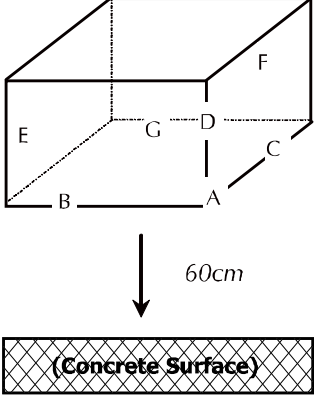
6	Vibration Test	Total fixed amplitude: 1.5mm. Vibration Frequency: 10~55Hz. One cycle 60 seconds to 3 direction of X, Y, Z each 15 minutes.	3
7.	Drop Test	To be measured after dropping from 60cm high on the concrete surface in packing state.  <p><i>Dropping method corner dropping:</i></p> <p><i>A corner: Once edge dropping.</i></p> <p><i>B, C, D edge: Once face dropping.</i></p> <p><i>E, F, G face: Once.</i></p>	

- Notes:
1. No dew condensation to be observed.
 2. The function test shall be conducted after 4 hours storage at the normal temperature and humidity after removed from the test chamber.
 3. Vibration test will be conducted to the product itself without putting I in a container.

9 Dimensional Outlines

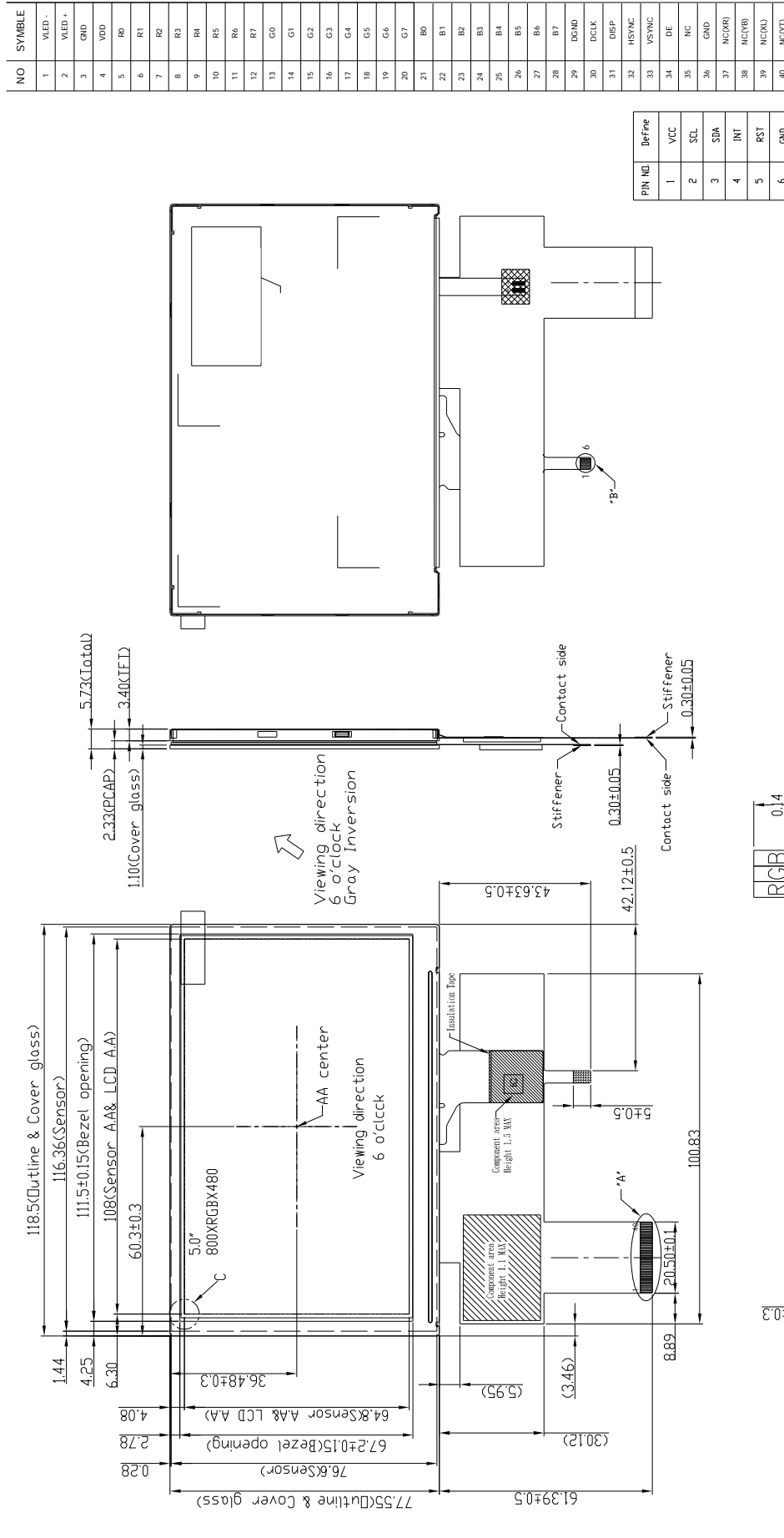

NO	SYMBLE
1	VLED-
2	VLED+
3	GND
4	VDD
5	R0
6	R1
7	R2
8	R3
9	R4
10	R5
11	R6
12	R7
13	G0
14	G1
15	G2
16	G3
17	G4
18	G5
19	G6
20	G7
21	B0
22	B1
23	B2
24	B3
25	B4
26	B5
27	B6
28	B7
29	DGND
30	DCLK
31	DISP
32	HSYNC
33	VS SYNC
34	DE
35	NC
36	GND
37	NC(XR)
38	NC(YR)
39	NC(XL)
40	NC(YL)

PIN NO.	Define
1	VCC
2	SCL
3	SDA
4	INT
5	RST
6	GND

TFT FPC Matching connector: Hirose FH12A-4DS-0.5SH or Equivalent.
 PCAP FPC Matching connector: Hirose FH34SJ-6S-0.5SH or Equivalent.

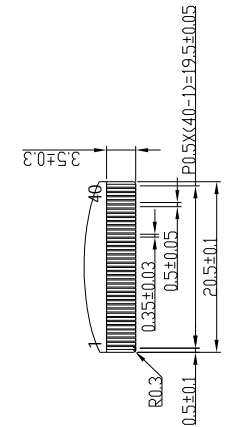
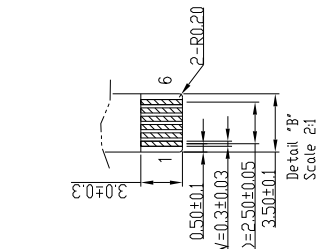
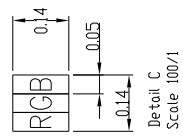

10 Incoming Inspection Standards

10.1 Inspection and Environment Conditions

10.1.1 Inspection Conditions:

- (1) Inspection Distance: 35 cm±5cm
- (2) View Angle : Light-on Inspection Angle : ±5°
Cosmetic Inspection Angle : ±45°

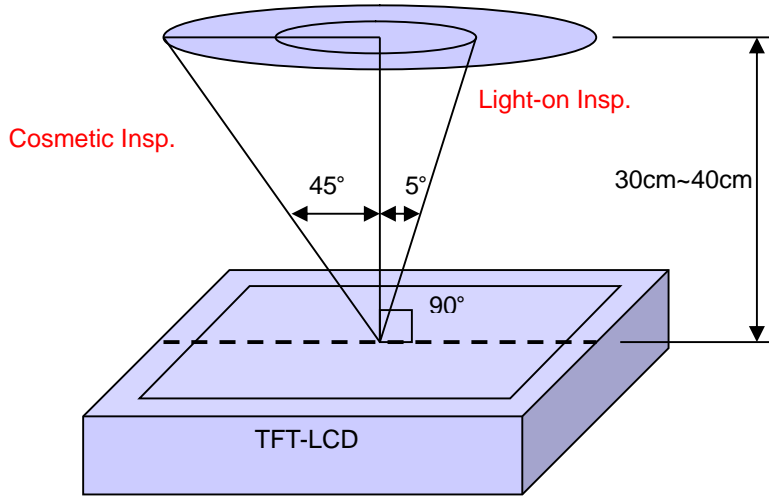

(perpendicular to LCD panel surface)

10.1.2 Environment Conditions:

Ambient Temperature		23°C±5°C
Ambient Humidity		55±10%RH
Ambient Illumination	Cosmetic Inspection	more than 600 Lux
	Functional Inspection	300~500 Lux

10.1.3 Sampling Conditions:

- (1) Lot Size: Quantity of shipment lot per model
- (2) Sampling Method:

Sampling Plan		MIL-STD-105E
		Normal Inspection, Single Sampling
		Level II
AQL	Major Defect	1.0%
	Minor Defect	1.5%

- (3) The classification of Major(MA) and Minor(MI) defects is shown as 3. Inspection Criteria.

10.1.4 Inspection Criteria

10.1.4.1 Cosmetic Inspection(Panel):

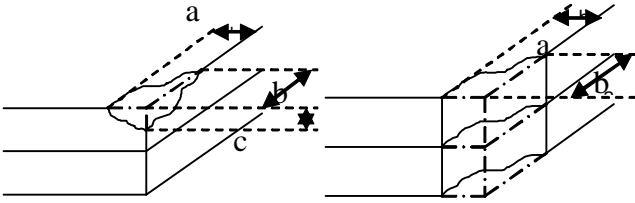
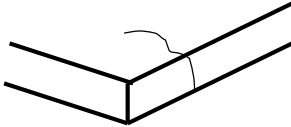
Item	Judgment Criteria	Classification
Chipping on Panel	 <p>$a \leq 3.0\text{mm}$、$b \leq 3.0\text{mm}$、$c \leq t$ (Bottom glass thickness)</p>	MA
Scratch on Panel *Note-2	<p>$W \leq 0.05\text{mm}$ or $L < 5\text{mm}$: Ignored $0.05\text{mm} < W \leq 0.1\text{mm}$ and $L \leq 5\text{mm}$: $N \leq 5$ $W > 0.1\text{mm}$ or $L > 5\text{mm}$: Not allowed</p>	MI
Bubble or Dent on Panel *Note-3	<p>$D \leq 0.2\text{mm}$: Ignored $0.2\text{mm} < D \leq 0.3\text{mm}$: $N \leq 5$ $D > 0.3\text{mm}$: Not allowed</p>	MI
Panel Crack	 <p>Not Allowed crack</p>	MA
Bezel Deformation	Obvious deformation is not allowed.	MI
Bezel Oxidation	Not allowed if it rusts continuously over 1 cm (It is out of warranty with rusted tin plate)	MI
Bezel Scratch	$L \leq 20\text{mm}$, $W \leq 0.2$, $N \leq 3$	MI
Metal Squash Dent /Flange(Front Side)	$D(W) \leq 1, L \leq 3, N \leq 3$;	MI
B/L High Voltage Wire Denudation	Not allowed	MA
Polarizer flaw or leak out resin	Defect is defined as the active area.	MI
Outline Dimension	Must in Spec, refer to related product spec.	MI

10.1.4.2 Functional Inspection:

Item	Judgment Criteria			Classification	
	Area(Note1)	I	O		
Point Defect	Bright dot	Random	2		MI
		2 dots adjacent	0	0	
		3 dots adjacent or more	0	0	
	Dark dot	Random	3		
		2 dots adjacent	0		
		3 dots adjacent or more	0	0	
	Total Dot Defect		5		
	Distance	Distance between Bright and Bright dot	$L \geq 5\text{mm}$		
		Distance between Bright and Dark dot	$L \geq 5\text{mm}$		
		Distance between Dark dot	$L \geq 5\text{mm}$		
(1) It is defined as Point Defect if defect area $> 0.5\text{dot}$ (2) It is ignored if defect area $\leq 0.5\text{dot}$ (3) Weak point defect will be defined as Bright Dot if it can be observed through ND filter 5% (Full Screen Black Inspection)					
Line Defect	Obvious vertical or horizontal line defect is not allowed.			MA	
Mura	Not allowed if it can be observed through ND Filter 5 %			MI	
Foreign Material in spot shape *Note-3	$D \leq 0.2\text{mm}$: Ignored $0.2\text{mm} < D \leq 0.5\text{mm}$: $N \leq 8$ $D > 0.5\text{mm}$: Not allowed			MI	
Foreign Material in line or spiral shape *Note-4	$W \leq 0.05\text{mm}$ or $L \leq 5\text{mm}$: Ignored $0.05\text{mm} < W \leq 0.2\text{mm}$ and $L 1.0\text{mm} \leq 5\text{mm}$: $N \leq 8$ $W > 0.2\text{mm}$ or $L > 5\text{mm}$: Not allowed			MI	
Display Function Abnormal	No Malfunction can be allowed			MA	

Note-1 : I/O Area Definition

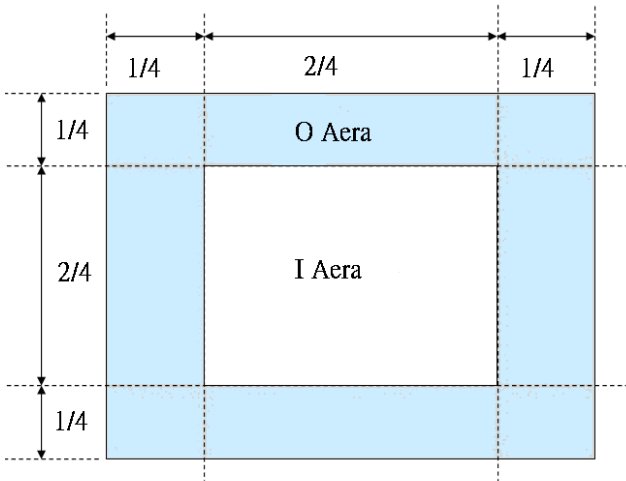

Note-2 : Polarizer Scratch

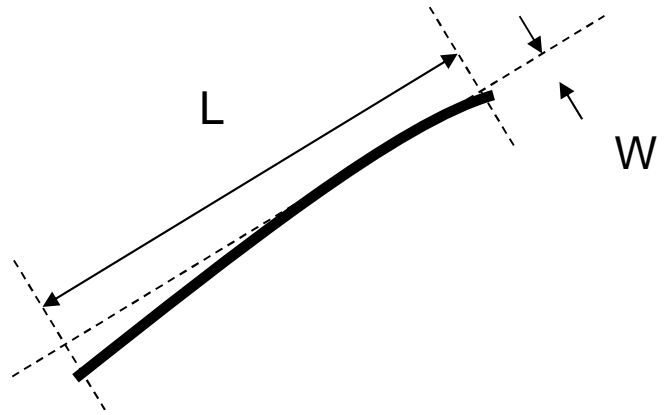

Note-3 : Spot Foreign Material
($W \geq L / 4$)

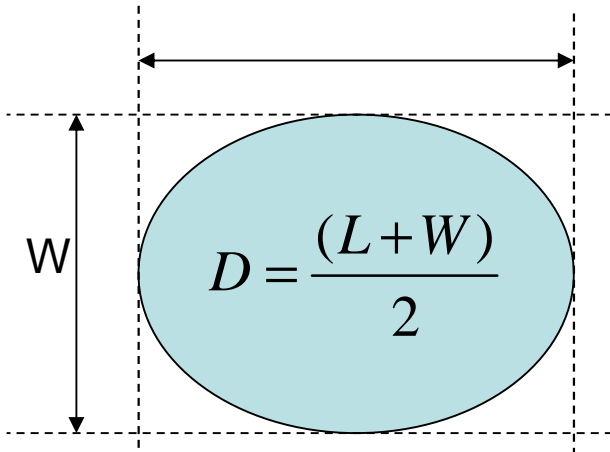

Note-4 : Line or Spiral Foreign Material
($W < L / 4$)

