

DISPLAY Elektronik GmbH

DATA
SHEET

TFT MODULE

DEM 8001280A VMH-PW-N

7,0" TFT

Product Specification

Version: 1

01.02.2018

Revision History

VERSION	DATE	REVISED PAGE NO.	Note
0	28.08.2017	-	First Issue
1	01.02.2018	P15	Modify LED Driving Conditions

Contents

1. Summary
2. General Specification
3. Interface
4. Counter Drawing
5. Block Diagram
6. Absolute Maximum Ratings
7. Electrical Characteristics
8. Interface Timing Chart
9. Optical Characteristics
10. Reliability

2. Summary

This is a 7" Color TFT-LCD (Thin Film Transistor Liquid Crystal Display) module composed of LCD panel, LVDS driver ICs, control circuit and backlight. By applying 6 bits +Hi-FRC digital data, 800xRGBx1280 Dots, 16.7M-color images are displayed on the 7" diagonal screen. General specifications are summarized in the following table

2. General Specifications

- Size: 7.0 Inch
- Dot Matrix: 800 x RGB x 1280 Dots
- Module Dimension: 164.61 x 106.30 x 6.00 mm
- Active Area: 150.72 x 94.20 mm
- Dot Pitch: 0.11775 x 0.11775 mm
- LCD Type: IPS TFT, Normally Black, Transmissive
- Viewing Angle(CR>10): 85/85/85/85
- Aspect Ratio: 16:9
- Backlight Type: LED ,Normally White
- Interface: LVDS
- Pixel Configuration: R.G.B. Vertical Stripe
- With /Without TP: Without TP
- Surface: Anti-Glare

*Color tone slight changed by temperature and driving voltage.

3. Interface

3.1. LCM PIN Definition: CN (Interface signal)

Pin No.	SYMBOL	I/O	FUNCTION	NOTE
1	NC	-	Not connect (CPT Test only)	
2	VDD	P	Digital power	
3	VDD	P	Digital power	
4	NC	-	Not connect (CPT Test only)	
5	REST	I	Global reset. Keep 3.3V+/-0.3V during operation. Normally pull high(High=3.3V+/-0.3V, Low=GND). (R=10KΩ , C=1uf)	
6	STBYB	I	Standby mode control. Normally pull high. When STBYB=H, Normal operation. (Default) When STBYB=L, TCON and source driver are off and all output are High-Z. (High=3.3V+/-0.3V, Low=GND)	
7	GND	P	Ground	
8	RXIN0-	I	Negative LVDS differential data inputs	
9	RXIN0+	I	Positive LVDS differential data inputs	
10	GND	P	Ground	
11	RXIN1-	I	Negative LVDS differential data inputs	
12	RXIN1+	I	Positive LVDS differential data inputs	
13	GND	P	Ground	
14	RXIN2-	I	Negative LVDS differential data inputs	
15	RXIN2+	I	Positive LVDS differential data inputs	
16	GND	P	Ground	
17	RXCLKIN-	I	Negative LVDS differential clock inputs	
18	RXCLKIN+	I	Positive LVDS differential clock inputs	
19	GND	P	Ground	
20	RXIN3-	I	Negative LVDS differential data inputs	
21	RXIN3+	I	Positive LVDS differential data inputs	
22	GND	P	Ground	
23	TP_SYNC	O	Sync signal for touch panel, keep floating if not used.	
24	NC	-	Not connect (CPT Test only)	
25	GND	P	Ground	
26	NC	-	Not connect (CPT Test only)	
27	NC	-	Not connect (CPT Test only)	
28	NC	-	Not connect (CPT Test only)	
29	AVDD	P	Power for Analog Circuit(AVDD = 12.080V±0.2V)	
30	GND	P	Ground	
31	LED-	P	LED Cathode	
32	LED-	P	LED Cathode	
33	L/R	-	Left/right selection (High= 1.8V±0.1V)Normally pull high	Note1
34	U/D	-	Up/down selection (High= 1.8V±0.1V)Normally pull high	Note1
35	VOFF	P	Negative power for TFT(VOFF = -6.0V±0.6V)	
36	NC	-	Not connect (CPT Test only)	
37	NC	-	Not connect (CPT Test only)	

38	VON	P	Positive power for TFT(VON = -24.0V±1V)	
39	LED+	P	LED ANODE	
40	LED+	P	LED ANODE	

Note1: Selection of scanning mode

Setting of scan control input		Scanning direction
U/D(Normally Pull high)	L/R(Normally Pull high)	
1.8V	1.8V	UP to down,left to right(Default)
GND	GND	Down to up,right to left
1.8V	GND	UP to down, right to left
GND	1.8V	Down to up, left to right

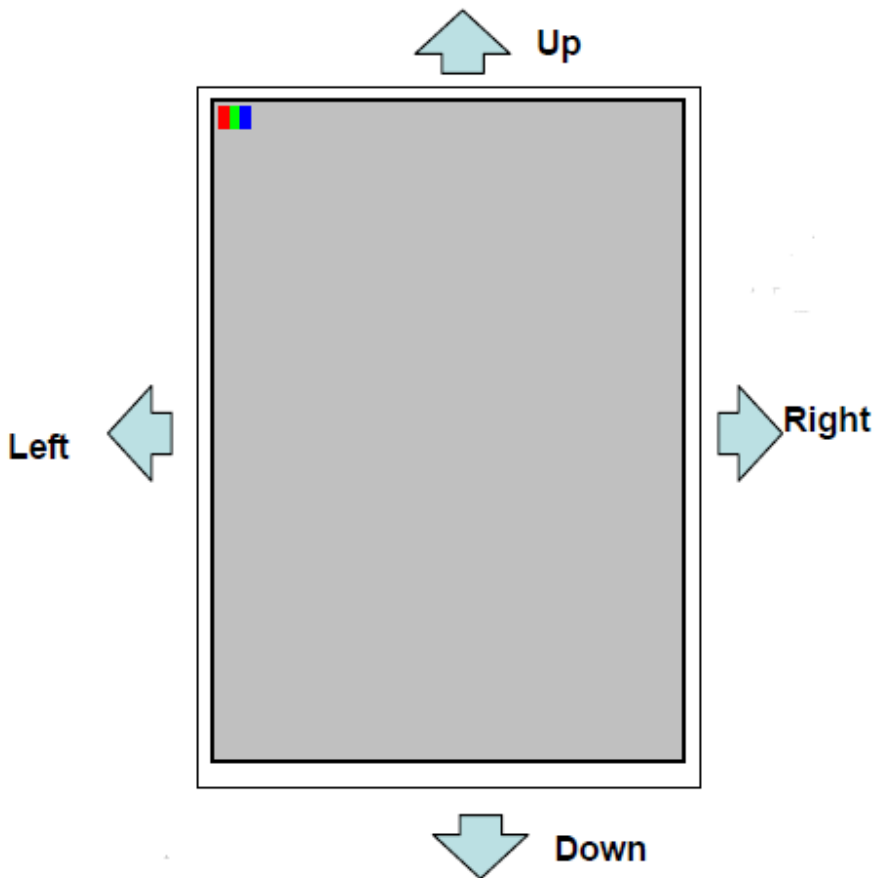

4. Counter Drawing

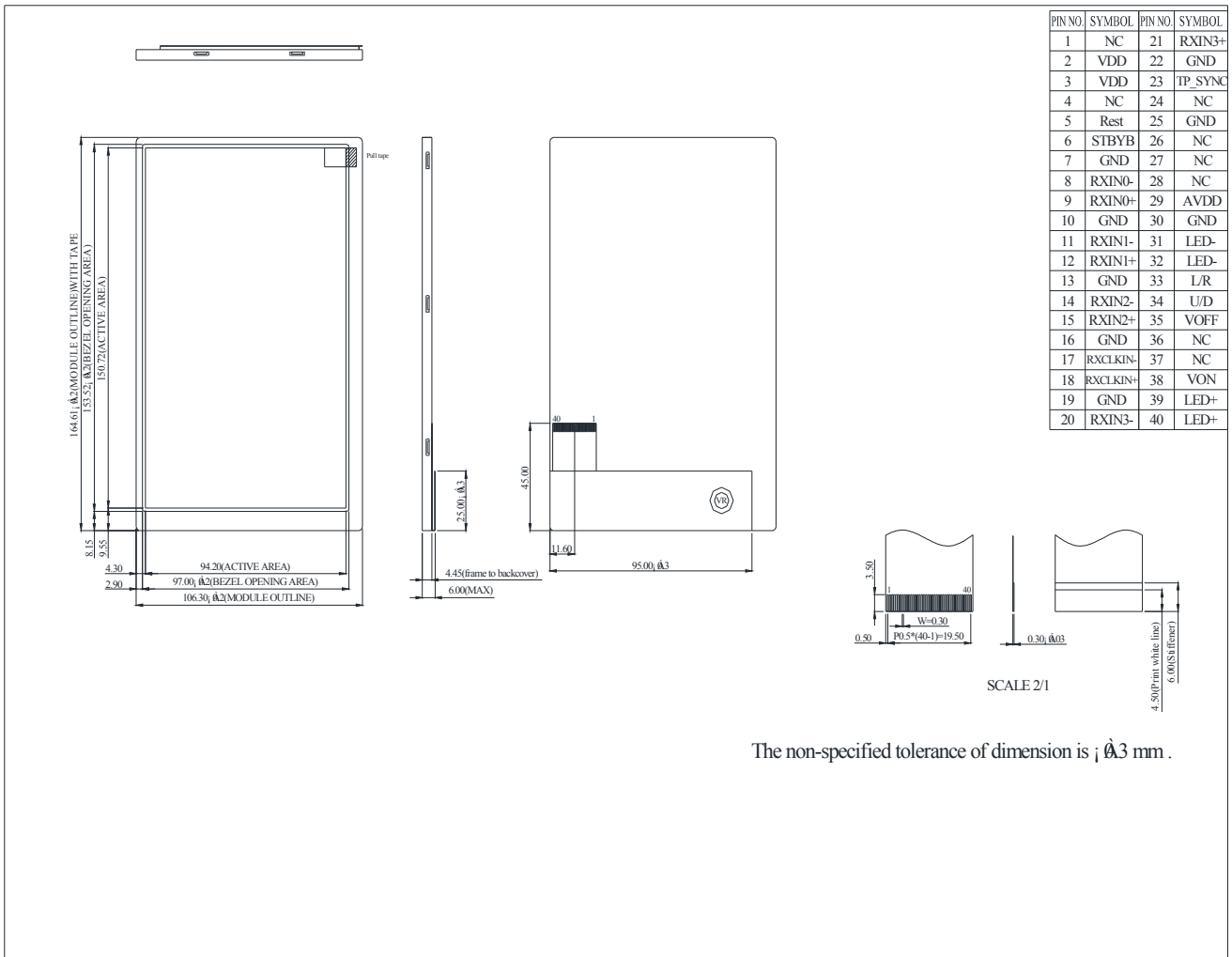

5. Block Diagram

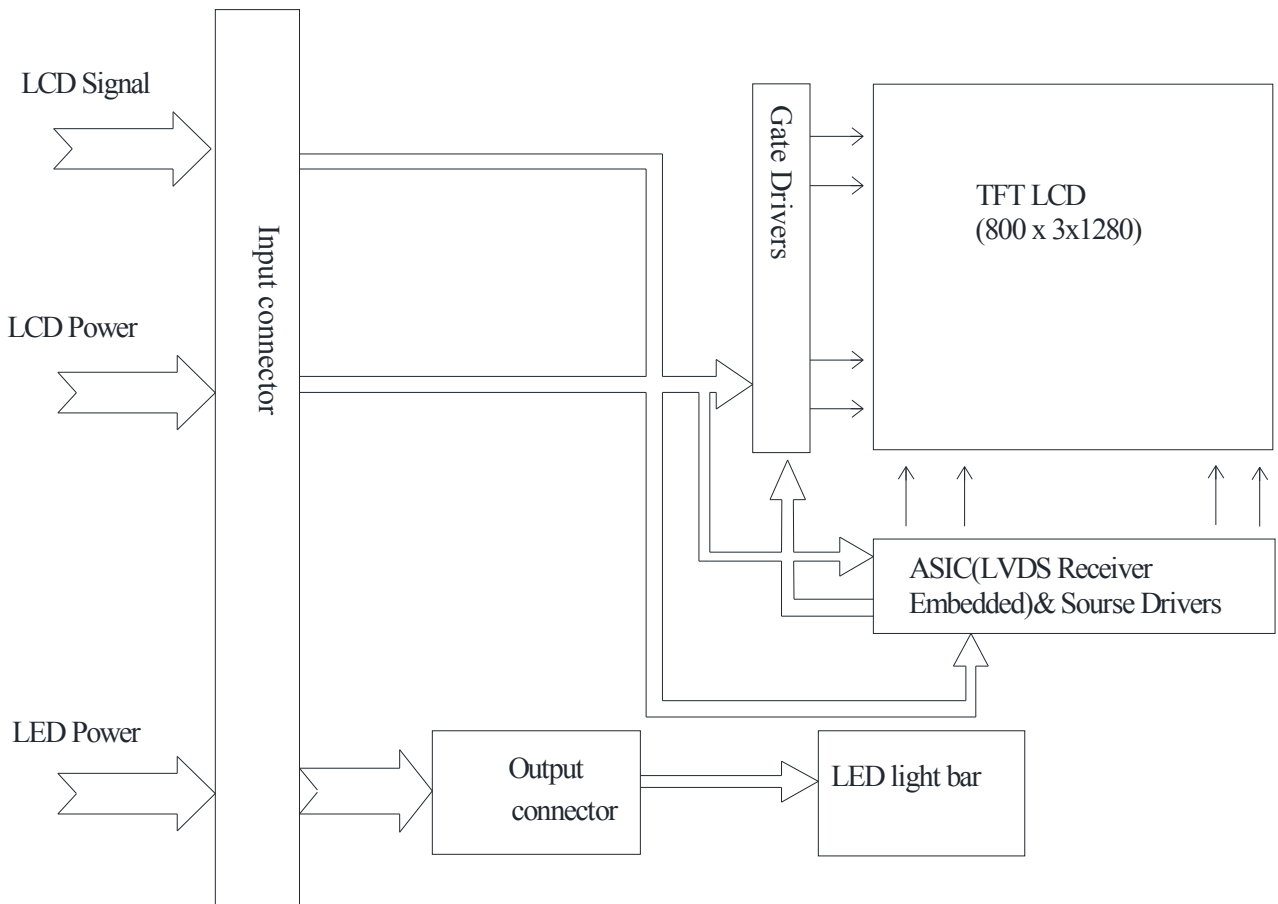

6. Absolute Maximum Ratings

Item	Symbol	Min	Typ	Max	Unit
Operating Temperature	TOP	-20	—	+70	°C
Storage Temperature	TST	-30	—	+80	°C

Note: Device is subject to be damaged permanently if stresses beyond those absolute maximum ratings listed above

1. Temp. $\leq +60^{\circ}\text{C}$, 90% RH MAX. Temp. $> +60^{\circ}\text{C}$, Absolute humidity shall be less than 90% RH at $+60^{\circ}\text{C}$

7. Electrical Characteristics

7.1. TFT LCD
Ta=+25°C

ITEM	SYMBOL	MIN	TYP	MAX	UNIT	Note
Digital Power Supply Voltage For LCD	DVDD	3	3.3	3.6	V	Note4
Logic Input Voltage (LVDS:IN+,IN-)	VCM	1	1.2	1.4	V	Note1
	VID	200	-	600	mV	Note1
	VTH	-	-	100	mV	VCM=1.2V Note1
	VTL	-100	-	-	mV	Note1
1 Data Time	UI	-	tclk*1/7	-	Tclk	Note3
LVDS Clock to Data Skew	tskew	-	-	300	Ps	Note3
Input Data Eye Width	teyew	1082	-	-	Ps	Note3
Analog Power Supply Voltage	AVDD	11.880	12.080	12.280	V	Note4
Gate On Power Supply Voltage	VON	22.5	23.4	24.5	V	Note4
Gate Off Power Supply Voltage	VOFF	-6.6	-6.0	-5.4	V	Note4
Common Power Supply Voltage	VCOM	3.45	4.15	4.85	V	Note2
Logic Input Voltage	VIH	0.8* DVDD	-	DVDD	V	Note2
	VIL	GND	-	0.2* DVDD	V	

7.2. TFT-LCD Current Consumption

ITEM	SYMBOL	MIN	TYP	MAX	UNIT	NOTE
Rush Current	Irush	-	-	2	A	Note6
Gate On Power Current	IVON	-	0.5	5	mA	Note5
Gate Off Power Current	IVOFF	-	0.5	5	mA	Note5
Digital Power Current	IVDD	-	40	80	mA	Note5
Analog Power Current	IAVDD	-	90	150	mA	Note5

Note1: LVDS DC electrical characteristics

LVDS Single-End Signal

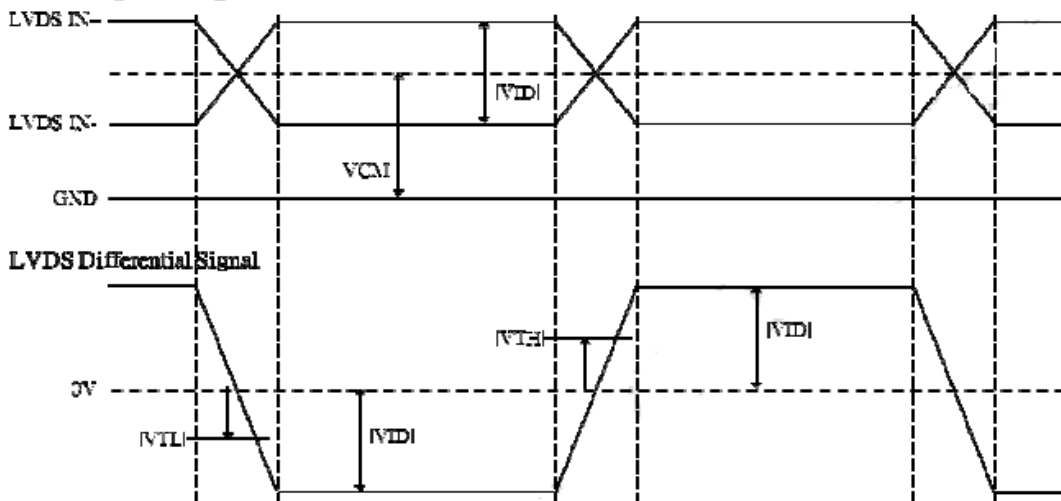

Note2: Vcom is supplied from FPCA, it could be adjusted by VR to make the flicker level be Minimum

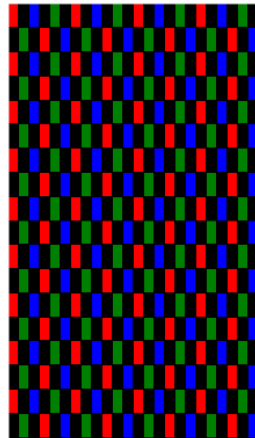

Flicker pattern

Note3: LVDS AC electrical characteristics

Differential LVDS signal: The following condition is base on operation frequency at **85MHz**

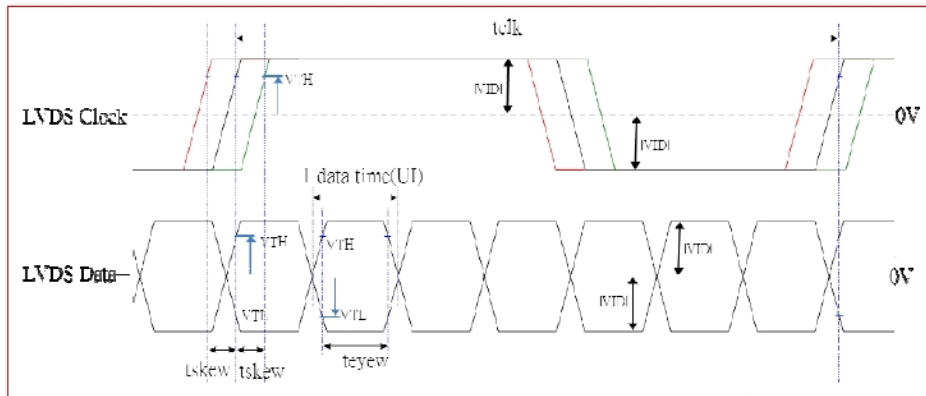

Note4:

(1) POWER SEQUENCE

Power ON : VDD→AVDD/VOFF→VON→Video & Logic Signal

Power off: Video & Logic Signal→VON→AVDD/VOFF→VDD

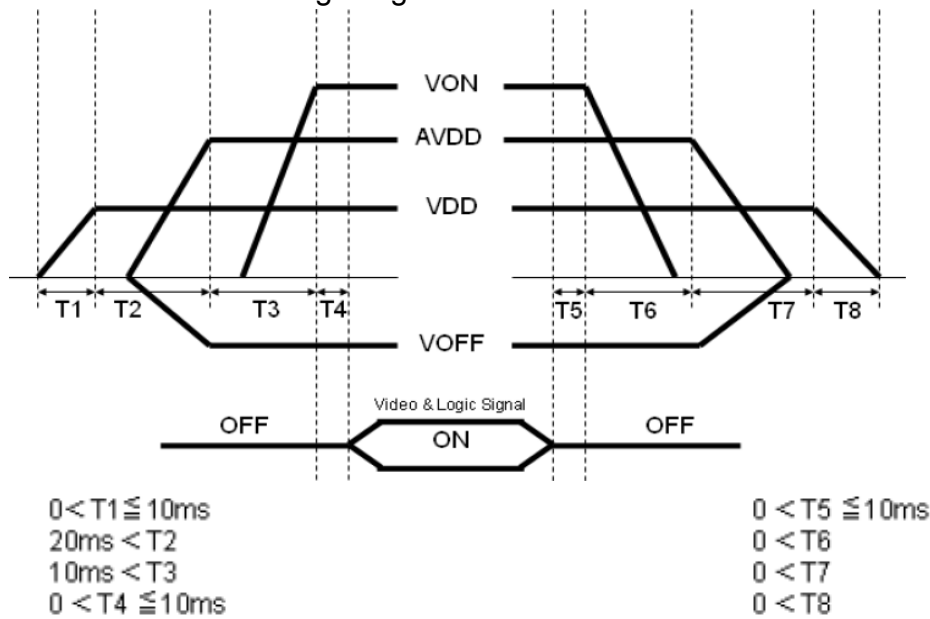

(2) Vin-dip state

(1) when $3.0V > V_{in} \geq 2.7V$, $t_d \leq 10ms$

(2) when $V_{in} < 2.7V$, Vin-dip condition should as the Vin-turn-off condition.

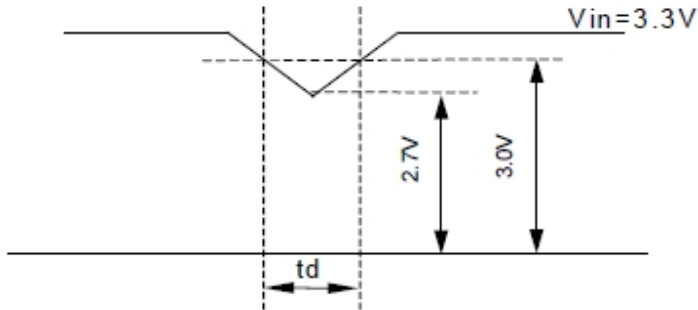

Note5: Typ. value is White Pattern: 1280 line mode.

Circuit condition (Typ): VDDI=3.3 V, fV=60 Hz, fH=77.28 kHz, fCLK=66.77 MHz



Note6: Irush measure condition

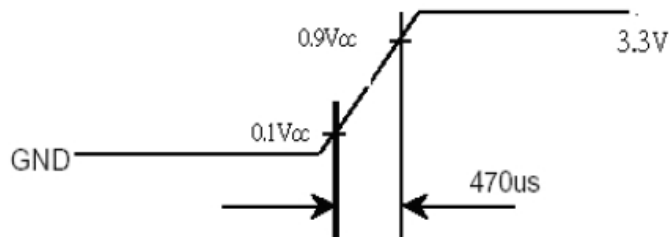
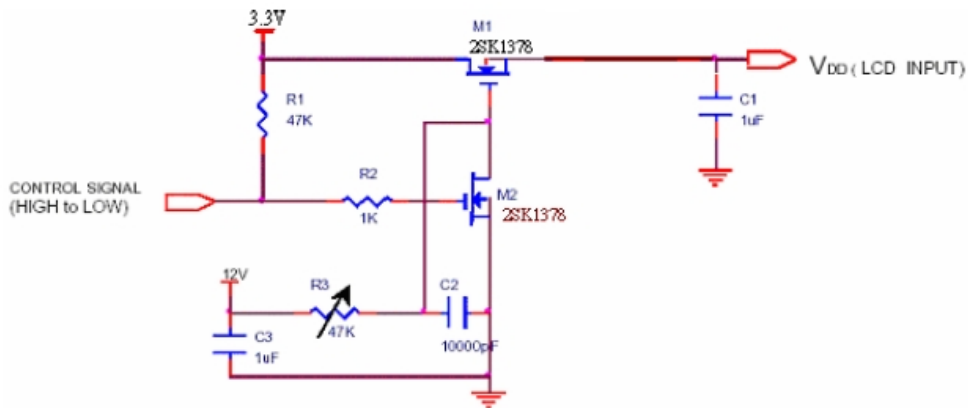

7.3. LED Driving Conditions

Parameter	Symbol	Min.	Typ.	Max.	Unit	Remark
LED Current	I _{LED}	-	102	-	mA	Note 5
Power Consumption	-	-	2.142	-	W	
LED Voltage	LED+	19.6	21.0	23.8	V	Note 1
LED Lifetime	-	50000	-	-	Hr	Note 2,3,4

Note 1 : : There are 1 Groups LED

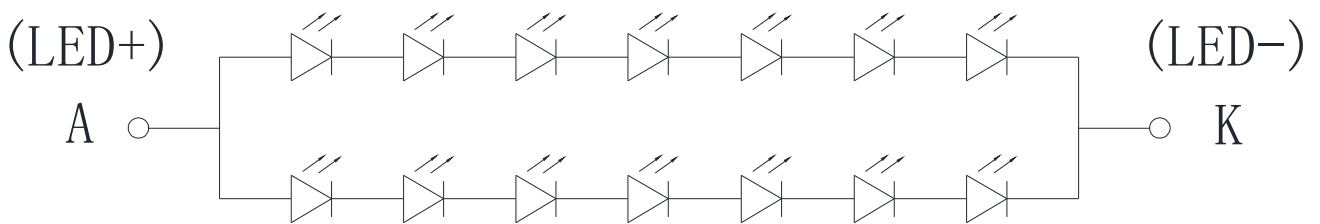

Note 2 : Ta = +25°C

Note 3 : Brightness to be decreased to 50% of the initial value

Note 4 : The single LED lamp case

Note 5: Make sure LED current less than Max. value

8. Interface Timing Chart

8.1. (a) LVDS Input Time Sequence

Horizontal Sequence

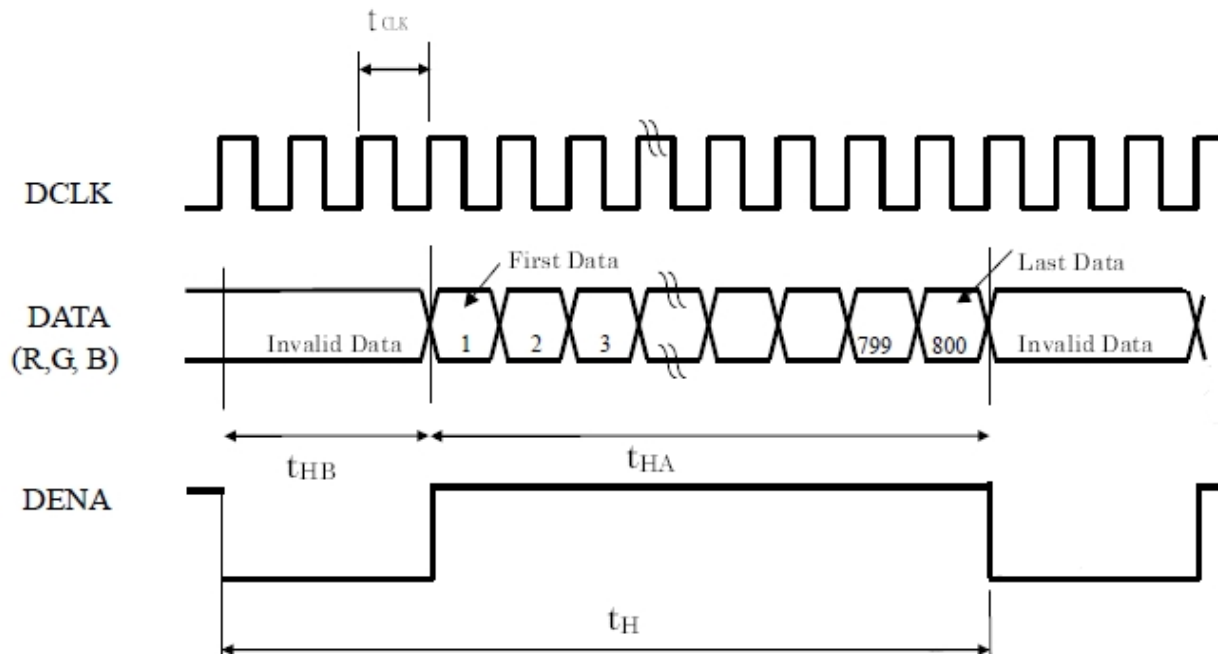

(b) LCD Input Time Sequence

Vertical sequence

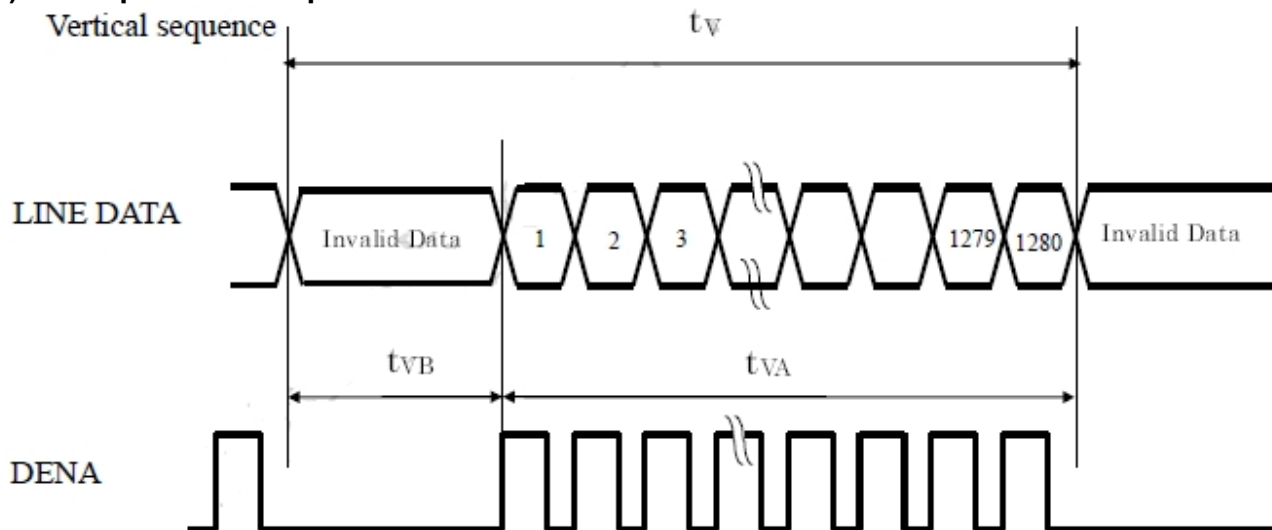

(c)LVDS Input Data Mapping

8 Bit LVDS input

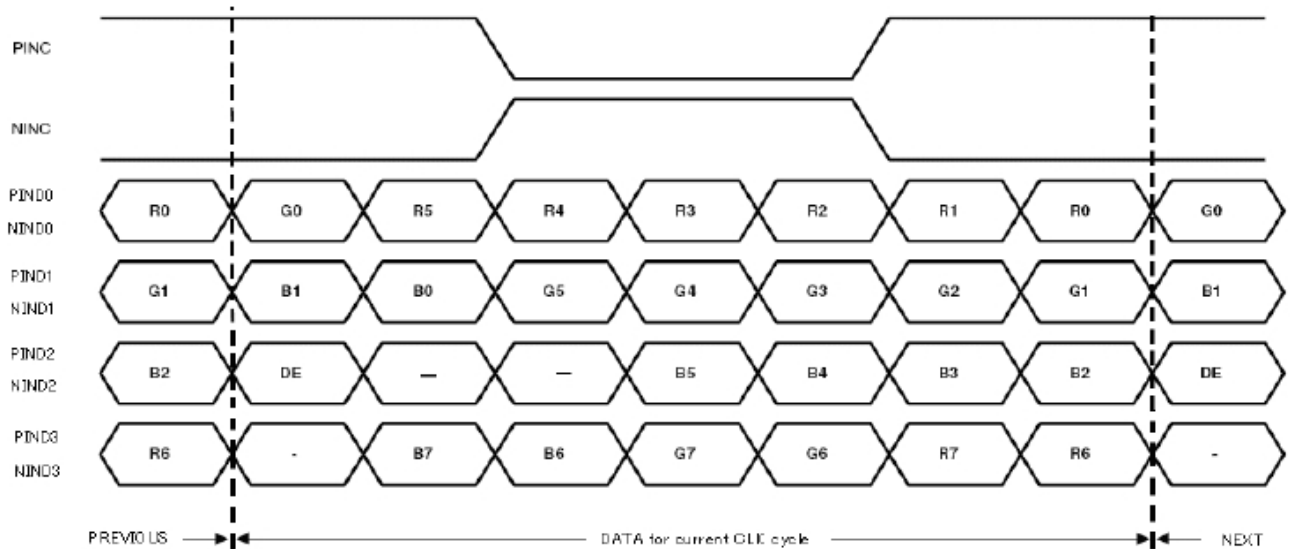

8.2. Timing Chart

		Item	Symbol	Min	Typ	Max	Unit	
LCD Timing	Frame Rate		-	60	60	60	Hz	
	DCLK		Frequency	Fclk	66.3	66.8	85	MHz
	DENA	Horizontal	Horizontal total time	tH	860	864	1026	t _{CLK}
			Horizontal Active time	t _{HA}	800	800	800	t _{CLK}
			Horizontal Blank time	t _{HB}	60	64	226	t _{CLK}
	DENA	Vertical	Vertical total time	tV	1286	1288	1380	tH
			Vertical Active time	t _{VA}	1280	1280	1280	tH
			Vertical Blank time	t _{VB}	6	8	100	tH

Note:

*1) DENA(DATA ENABLE)usually is positive

*2)During the whole blank period,DCLK should keep input

8.3. DATA Mapping

COLOR	INPUT DATA	R DATA								G DATA								B DATA							
		R7 MSB	R6	R5	R4	R3	R2	R1	R0 LSB	G7 MSB	G6	G5	G4	G3	G2	G1	G0 LSB	B7 MSB	B6	B5	B4	B3	B2	B1	B0 LSB
BASIC COLOR	BLACK	0	0	0	0	0	0	0	0	0	0	0	0	0	0	0	0	0	0	0	0	0	0	0	0
	RED(255)	1	1	1	1	1	1	1	1	0	0	0	0	0	0	0	0	0	0	0	0	0	0	0	
	GREEN(255)	0	0	0	0	0	0	0	0	1	1	1	1	1	1	1	0	0	0	0	0	0	0	0	
	BLUE(255)	0	0	0	0	0	0	0	0	0	0	0	0	0	0	0	1	1	1	1	1	1	1	1	
	CYAN	0	0	0	0	0	0	0	0	1	1	1	1	1	1	1	1	1	1	1	1	1	1	1	
	MAGENTA	1	1	1	1	1	1	1	1	0	0	0	0	0	0	0	1	1	1	1	1	1	1	1	
	YELLOW	1	1	1	1	1	1	1	1	1	1	1	1	1	1	1	0	0	0	0	0	0	0	0	
	WHITE	1	1	1	1	1	1	1	1	1	1	1	1	1	1	1	1	1	1	1	1	1	1	1	
RED	RED(0)	0	0	0	0	0	0	0	0	0	0	0	0	0	0	0	0	0	0	0	0	0	0		
	RED(1)	0	0	0	0	0	0	0	1	0	0	0	0	0	0	0	0	0	0	0	0	0	0		
	RED(2)	0	0	0	0	0	0	1	0	0	0	0	0	0	0	0	0	0	0	0	0	0	0		
	RED(254)	1	1	1	1	1	1	1	0	0	0	0	0	0	0	0	0	0	0	0	0	0	0		
	RED(255)	1	1	1	1	1	1	1	1	0	0	0	0	0	0	0	0	0	0	0	0	0	0		
GREEN	GREEN(0)	0	0	0	0	0	0	0	0	0	0	0	0	0	0	0	0	0	0	0	0	0	0		
	GREEN(1)	0	0	0	0	0	0	0	0	0	0	0	0	0	1	0	0	0	0	0	0	0	0		
	GREEN(2)	0	0	0	0	0	0	0	0	0	0	0	0	0	1	0	0	0	0	0	0	0	0		
	GREEN(254)	0	0	0	0	0	0	0	1	1	1	1	1	1	1	0	0	0	0	0	0	0	0		
	GREEN(255)	0	0	0	0	0	0	0	1	1	1	1	1	1	1	0	0	0	0	0	0	0	0		
BLUE	BLUE(0)	0	0	0	0	0	0	0	0	0	0	0	0	0	0	0	0	0	0	0	0	0	0		
	BLUE(1)	0	0	0	0	0	0	0	0	0	0	0	0	0	0	0	0	0	0	0	0	0	1		
	BLUE(2)	0	0	0	0	0	0	0	0	0	0	0	0	0	0	0	0	0	0	0	0	1	0		
	BLUE(254)	0	0	0	0	0	0	0	0	0	0	0	0	0	0	1	1	1	1	1	1	1	0		
	BLUE(255)	0	0	0	0	0	0	0	0	0	0	0	0	0	0	1	1	1	1	1	1	1	1		

Note:

(1) Gray level: Color(n):n is level order;higher n means bright level.

(2) DATA : 1 : high; 0:low

9. Optical Characteristics

Item	Symbol	Condition.	Min	Typ.	Max.	Unit	Remark
Response Time	Tr	$\theta=0^\circ$ 、 $\phi=0^\circ$	-	25	35	.ms	Note 3
	Tf						
Contrast Ratio	CR	At optimized viewing angle	600	800	-	-	Note 4
Color Chromaticity	White	$\theta=0^\circ$ 、 $\phi=0$	0.256	0.306	0.356		Note 2,5,6
			0.290	0.340	0.390		
Viewing Angle	Hor.	Θ_R	80	85	-	Deg.	Note 1
		Θ_L	80	85	-		
	Ver.	Φ_T	80	85	-		
		Φ_B	80	85	-		
Brightness	-	-	360	450	-	cd/m ²	Center of display

Ta=25°C ± 2°C,

Note 1: Definition of viewing angle range

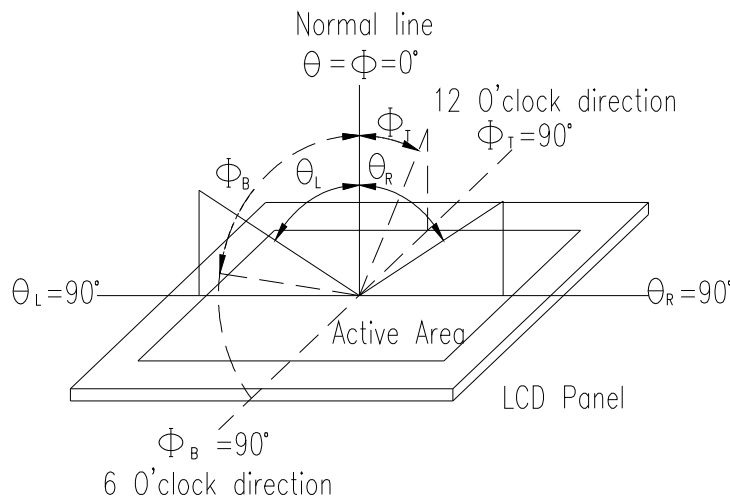

Fig. 10.1. Definition of viewing angle

Note 2: Test equipment setup:

After stabilizing and leaving the panel alone at a driven temperature for 10 minutes, the measurement should be executed. Measurement should be executed in a stable, windless, and dark room. Optical specifications are measured by Topcon BM-7or BM-5 luminance meter 1.0° field of view at a distance of 50cm and normal direction.

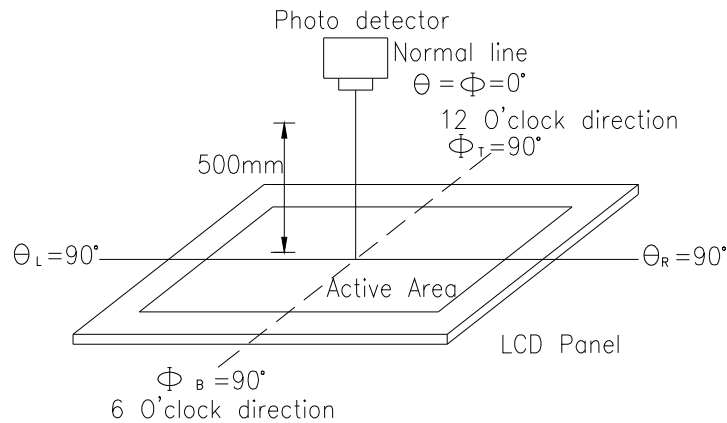
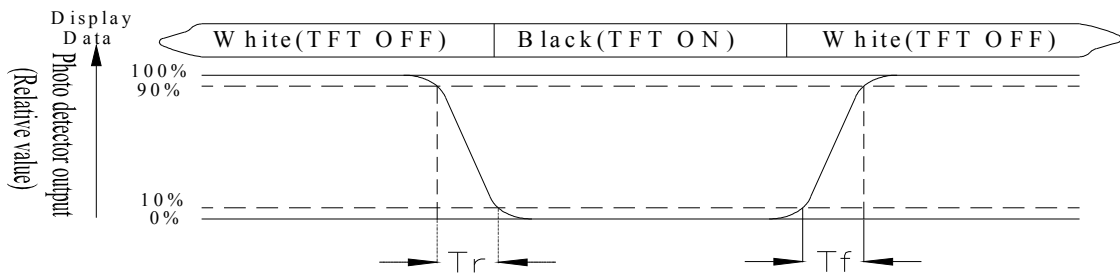

Fig. 10.2. Optical measurement system setup

Note 3: Definition of Response time:

The response time is defined as the LCD optical switching time interval between “White” state and “Black” state. Rise time, T_r , is the time between photo detector output intensity changed from 90% to 10%. And fall time, T_f , is the time between photo detector output intensity changed from 10% to 90%



Note 4: Definition of contrast ratio:

The contrast ratio is defined as the following expression.

$$\text{Contrast ratio (CR)} = \frac{\text{Luminance measured when LCD on the "White" state}}{\text{Luminance measured when LCD on the "Black" state}}$$

Note 5: White $V_i = V_{i50} \pm 1.5V$

Black $V_i = V_{i50} \pm 2.0V$

“±” means that the analog input signal swings in phase with VCOM signal.

“±” means that the analog input signal swings out of phase with VCOM signal.

The 100% transmission is defined as the transmission of LCD panel when all the input terminals of module are electrically opened.

Note 6: Definition of color chromaticity (CIE 1931)

Color coordinates measured at the center point of LCD

Note 7: Measured at the center area of the panel when all the input terminals of LCD panel are electrically opened.

10. Reliability

Content of Reliability Test (Wide temperature, -20°C~+70°C)

Environmental Test			
Test Item	Content of Test	Test Condition	Note
High Temperature storage	Endurance test applying the high storage temperature for a long time.	+80°C 200hrs	2
Low Temperature storage	Endurance test applying the low storage temperature for a long time.	-30°C 200hrs	1,2
High Temperature Operation	Endurance test applying the electric stress (Voltage & Current) and the thermal stress to the element for a long time.	+70°C 200hrs	—
Low Temperature Operation	Endurance test applying the electric stress under low temperature for a long time.	-20°C 200hrs	1
High Temperature/ Humidity Operation	The module should be allowed to stand at 60%, 90%RH max	+60°C, 90%RH 96hrs	1,2
Thermal shock resistance	The sample should be allowed stand the following 10 cycles of operation <div style="text-align: center;"> <p style="margin: 0;">-20°C +25°C +70°C</p> <p style="margin: 0;">30min 5min 30min</p> <p style="margin: 0;">1 cycle</p> </div>	-20°C / +70°C 10 cycles	—
Vibration test	Endurance test applying the vibration during transportation and using.	Total fixed amplitude : 1.5mm Vibration Frequency : 10~55Hz One cycle 60 seconds to 3 directions of X,Y,Z for Each 15 minutes	3
Static electricity test	Endurance test applying the electric stress to the terminal.	VS=±600V(Contact) ±800V(Air), RS=330Ω CS=150pF 10 times	—

Note1: No dew condensation to be observed.

Note2: The function test shall be conducted after 4 hours storage at the normal Temperature and humidity after remove from the test chamber.

Note3: The packing have to including into the vibration testing.