

Display Elektronik GmbH

DATA SHEET

TFT MODULE

**DEM 480272N TMH-PW-N
(C-TOUCH)**

4,3“ TFT + PCT

Product Specification

Version: 1.1.1

21.01.2016

Revision History

VERSION	DATE	REVISED PAGE NO.	Note
0	09.10.2014		Preliminary
1	09.10.2014		First issue
1.1.0	09.07.2015		Modify Reliability & Module dimension (H=4.21mm)
1.1.1	21.01.2016		Modify Static electricity test

Contents

1. Summary
2. General Specification
3. Interface
4. Contour Drawing
5. Block Diagram
6. Absolute Maximum Ratings
7. Electrical Characteristics
8. DC Characteristics
9. AC Characteristics
10. Optical Characteristics
11. Reliability
12. Touch Panel Information

1. Summary

This technical specification applies to 4.3' color TFT-LCD panel. The 4.3' color TFT-LCD panel is designed for camcorder, digital camera application and other electronic products which require high quality flat panel displays. This module follows RoHS.

2. General Specifications

- Size: 4.3 inch
- Dot Matrix: 480 x RGB x 272
- Module dimension: 105.50 x 67.2 x 4.21 mm
- Active area: 95.04 x 53.86 mm
- Dot pitch: 0.066 x 0.198 mm
- LCD type: TFT, Normally White, Transmissive
- View Direction: 12 o'clock
- Gray Scale Inversion Direction: 6 o'clock
- Backlight Type: LED, Normally White
- With /Without TP: With CTP
- Surface TFT: Glare

*Color tone slight changed by temperature and driving voltage.

3.Interface

3.1. LCM PIN Definition

Pin	Symbol	Function	Remark
1	VBL-	Power for LED backlight cathode	
2	VBL+	Power for LED backlight anode	
3	GND	Power ground	
4	VDD	Power voltage	
5	R0	Red data (LSB)	
6	R1	Red data	
7	R2	Red data	
8	R3	Red data	
9	R4	Red data	
10	R5	Red data	
11	R6	Red data	
12	R7	Red data (MSB)	
13	G0	Green data (LSB)	
14	G1	Green data	
15	G2	Green data	
16	G3	Green data	
17	G4	Green data	
18	G5	Green data	
19	G6	Green data	
20	G7	Green data (MSB)	
21	B0	Blue data (LSB)	
22	B1	Blue data	
23	B2	Blue data	
24	B3	Blue data	
25	B4	Blue data	
26	B5	Blue data	
27	B6	Blue data	
28	B7	Blue data (MSB)	
29	GND	Power ground	
30	DCLK	Pixel clock	
31	DISP	Display on/off	
32	NC	No connection	
33	NC	No connection	
34	DE	Data Enable	
35	NC	No connection	
36	GND	Power ground	
37	NC	No connection	
38	NC	No connection	
39	NC	No connection	
40	NC	No connection	

3.2. CTP PIN Definition

Pin	Symbol	Function	Remark
1	VSS	Ground for analog circuit	
2	VDDT	Power Supply : +3.0V	
3	SCL	I2C clock input	
4	NC	No connect	
5	SDA	I2C data input and output	
6	NC	No connect	
7	/RST	External Reset, Low is active	
8	/WAKE	External interrupt from the host	
9	/INT	External interrupt to the host	
10	VSS	Ground for analog circuit	

4. Contour Drawing

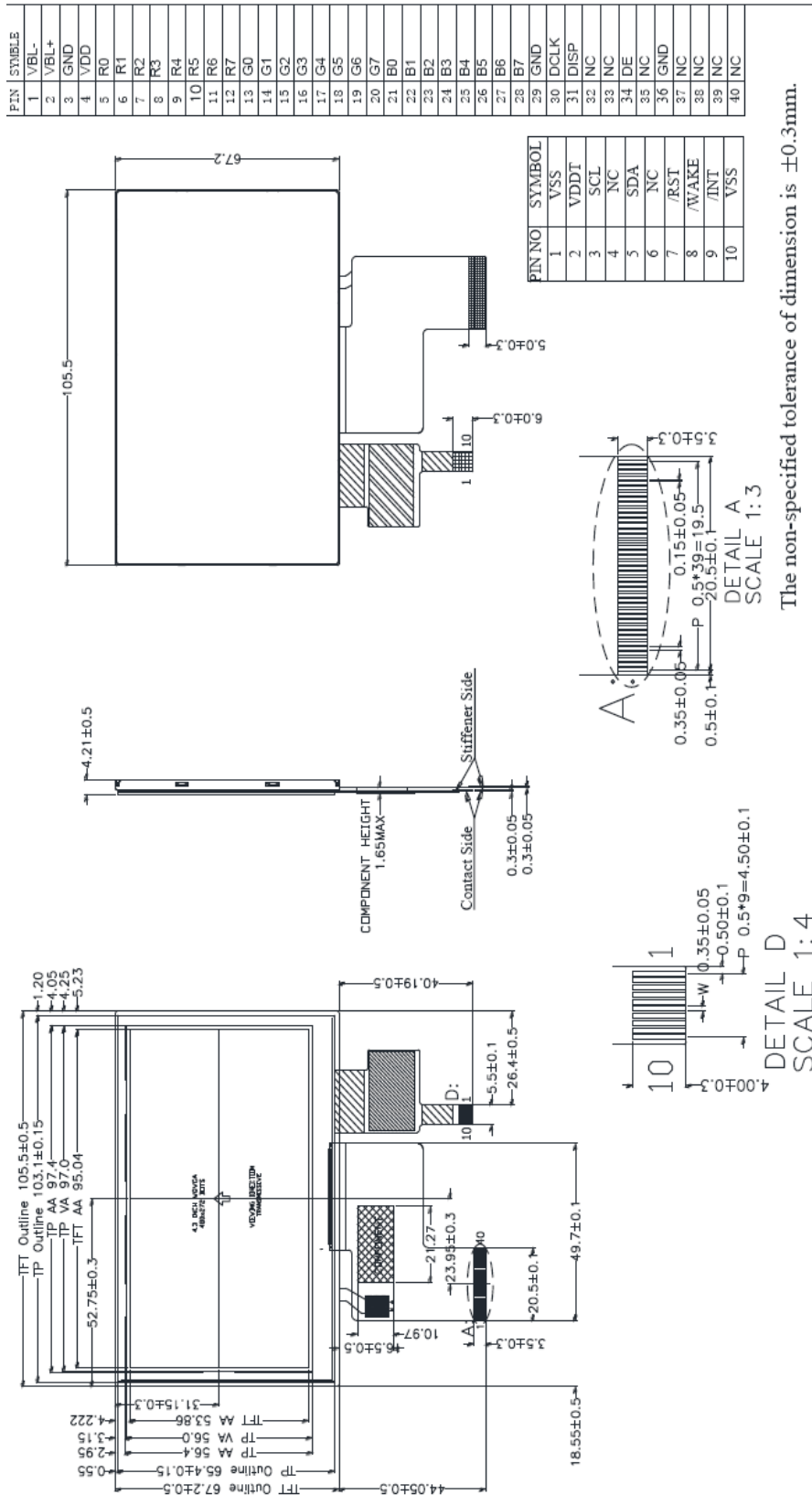

5. Block Diagram

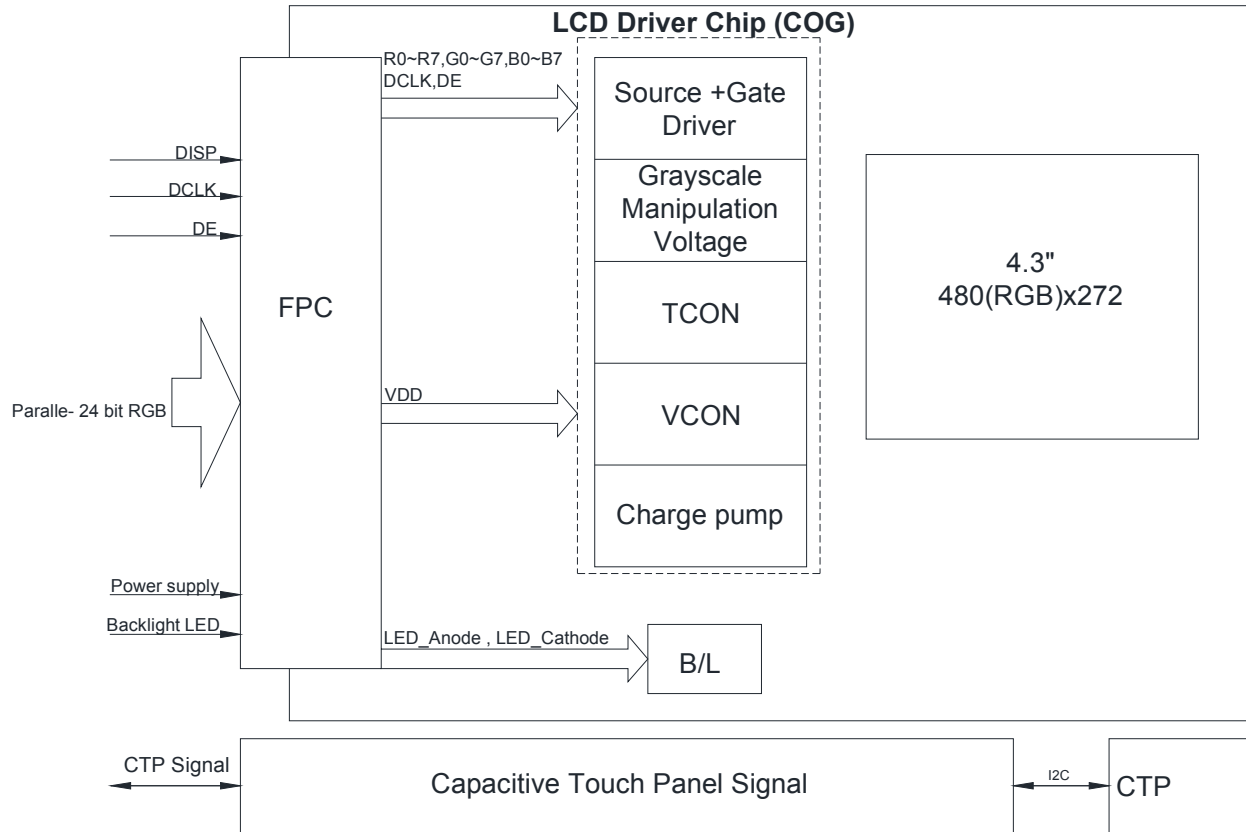

6. Absolute Maximum Ratings

Item	Symbol	Min	Typ	Max	Unit
Operating Temperature	TOP	-20	—	+70	°C
Storage Temperature	TST	-30	—	+80	°C

Note: Device is subject to be damaged permanently if stresses beyond those absolute maximum ratings listed above

- Temp. $\leq 60^{\circ}\text{C}$, 85% RH MAX. Temp. $> 60^{\circ}\text{C}$, Absolute humidity shall be less than 85% RH at 60°C

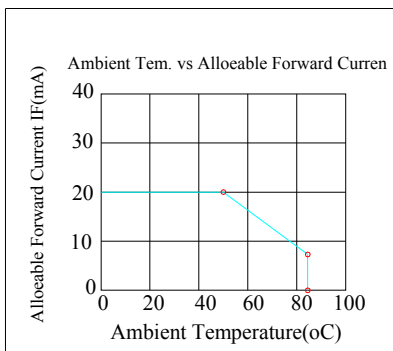

7. Electrical Characteristics

7.1. Operating conditions:

Item	Symbol	Condition	Min	Typ	Max	Unit
Supply Voltage For Logic	VDD	—	3	3.3	3.6	V
Digital operation current	IDD	—	—	17	25	mA
Supply Voltage For CTP	VDDT	--	2.8	3.1	3.3	V

7.2. LED driving conditions

Parameter	Symbol	Min.	Typ.	Max.	Unit	Remark
LED current	—	18	20	30	mA	
Power Consumption	—	—	640	990	mW	
LED voltage	VBL+	30	32	33	V	Note 1
LED Life Time		20,000	—	—	Hr	Note 2,3,4

Note 1 : There are 1 Groups LED

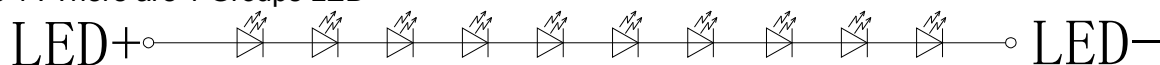

Note 2 : Ta = 25°C

Note 3 : Brightness to be decreased to 50% of the initial value

Note 4 : The single LED lamp case

8. DC CHARATERISTICS

Parameter	Symbol	Rating			Unit	Condition
		Min	Typ	Max		
Low level input voltage	VIL	GND	-	0.2 VDD	V	
High level input voltage	VIH	0.8 VDD	-	VDD	V	

9. Data input Characteristics

Parallel RGB Interface

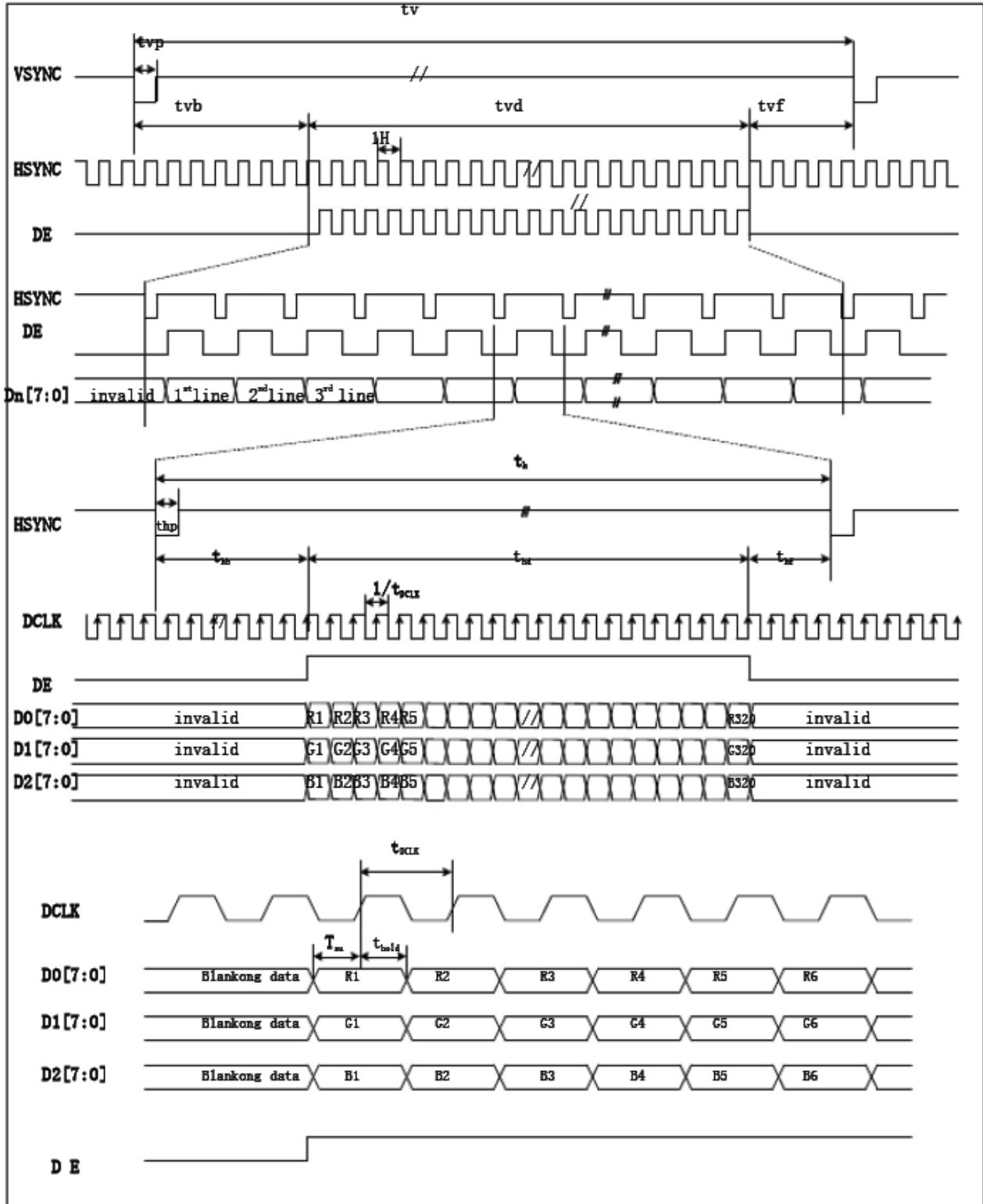

Parameter	Symbol	Min.	Typ.	Max.	Unit.	Note
DCLK Frequency	1/tDCLK	5	9	12	MHz	
Horizontal Period	th	520	525	800	tDCLK	
Horizontal Display	thd	-	480	-	tDCLK	
Horizontal Back Porch	thb	36	40	255	tDCLK	
Horizontal Front Porch	thf	4	5	65	tDCLK	
Horizontal Pulse Width	thp	1	-	-	tDCLK	
Vertical Period	tv	277	288	400	th	
Vertical Display Period	tvd	-	272	-	th	
Vertical Back Porch	tvb	3	8	31	th	
Vertical Front Porch	tvf	2	8	97	th	
Vertical Pulse Width	tvp	1	-	-	th	
Data setup time	tsu	12	-	-	ns	
Data hold time	thold	12	-	-	ns	

10. Optical Characteristics

Item	Symbol	Condition.	Min	Typ.	Max.	Unit	Remark
Response time	Tr	$\theta=0^\circ, \phi=0^\circ$	-	10	20	ms	Note 3
	Tf		-	15	30	ms	
Contrast ratio	CR	At optimized viewing angle	400	500	-	-	Note 4
Color Chromaticity	White	$\theta=0^\circ, \phi=0^\circ$	0.26	0.31	0.36	-	Note 2,5
			0.28	0.33	0.38	-	
Viewing angle (Gray Scale Inversion Direction)	Hor.	Θ_R	60	70	-	Deg.	Note 1
		Θ_L	60	70	-		
	Ver.	Φ_T	40	50	-		
		Φ_B	60	70	-		
Brightness	-	-	320	400	-	cd/m ²	Center of display

Ta=25±2°C

Note 1: Definition of viewing angle range

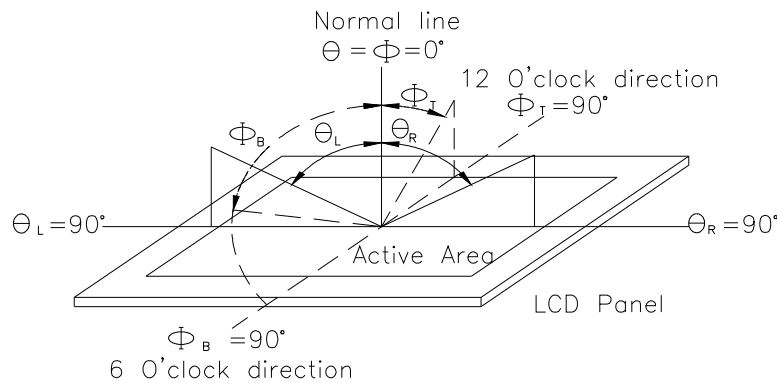

Fig. 11.1. Definition of viewing angle

Note 2: Test equipment setup:

After stabilizing and leaving the panel alone at a driven temperature for 10 minutes, the measurement should be executed. Measurement should be executed in a stable, windless, and dark room. Optical specifications are measured by Topcon BM-7orBM-5 luminance meter 1.0° field of view at a distance of 50cm and normal direction.

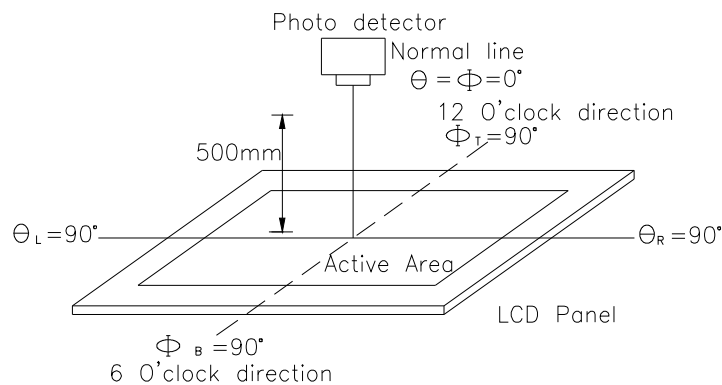
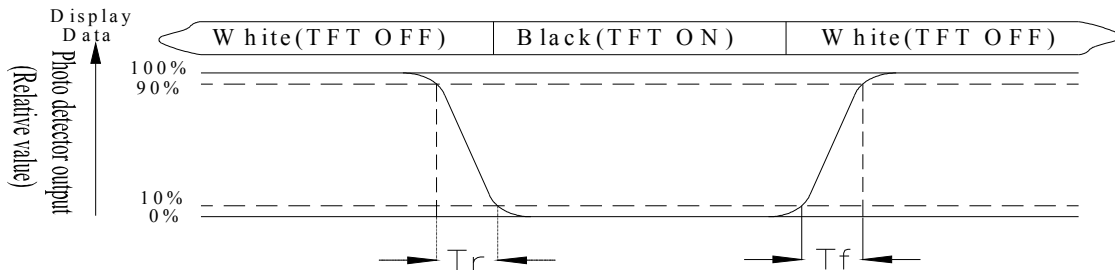

Fig. 11.2. Optical measurement system setup

Note 3: Definition of Response time:

The response time is defined as the LCD optical switching time interval between “White” state and “Black” state. Rise time, T_r , is the time between photo detector output intensity changed from 90% to 10%. And fall time, T_f , is the time between photo detector output intensity changed from 10% to 90%



Note 4: Definition of contrast ratio:

The contrast ratio is defined as the following expression.

$$\text{Contrast ratio (CR)} = \frac{\text{Luminance measured when LCD on the "White" state}}{\text{Luminance measured when LCD on the "Black" state}}$$

Note 5: White $V_i = V_{i50} \pm 1.5V$

Black $V_i = V_{i50} \pm 2.0V$

“±” means that the analog input signal swings in phase with VCOM signal.

“±” means that the analog input signal swings out of phase with VCOM signal.

The 100% transmission is defined as the transmission of LCD panel when all the input terminals of module are electrically opened.

Note 6: Definition of color chromaticity (CIE 1931)

Color coordinates measured at the center point of LCD

Note 7: Measured at the center area of the panel when all the input terminals of LCD panel are electrically opened.

11. Reliability

Content of Reliability Test (Wide temperature, -20°C~70°C)

Environmental Test			
Test Item	Content of Test	Test Condition	Note
High Temperature storage	Endurance test applying the high storage temperature for a long time.	80°C 96hrs	2
Low Temperature storage	Endurance test applying the low storage temperature for a long time.	-30°C 96hrs	1,2
High Temperature Operation	Endurance test applying the electric stress (Voltage & Current) and the thermal stress to the element for a long time.	70°C 96hrs	—
Low Temperature Operation	Endurance test applying the electric stress under low temperature for a long time.	-20°C 96hrs	1
High Temperature/ Humidity Operation	The module should be allowed to stand at 60°C,85%RH max	60°C,85%RH 96hrs	1,2
Thermal shock resistance	The sample should be allowed stand the following 10 cycles of operation <div style="text-align: center;"> <p>-20°C 25°C 60°C 30min 5min 30min 1 cycle</p> </div>	-20°C/60°C 10 cycles	—
Vibration test	Endurance test applying the vibration during transportation and using.	Total fixed amplitude : 15mm Vibration Frequency : 10~55Hz One cycle 60 seconds to 3 directions of X,Y,Z for Each 15 minutes	3
Static electricity test	Endurance test applying the electric stress to the terminal.	VS=±600V(contact), ±800v(air), RS=330Ω CS=150pF 10 times	—

Note1: No dew condensation to be observed.

Note2: The function test shall be conducted after 4 hours storage at the normal Temperature and humidity after remove from the test chamber.

Note3: The packing have to including into the vibration testing.

12. Touch Panel Information

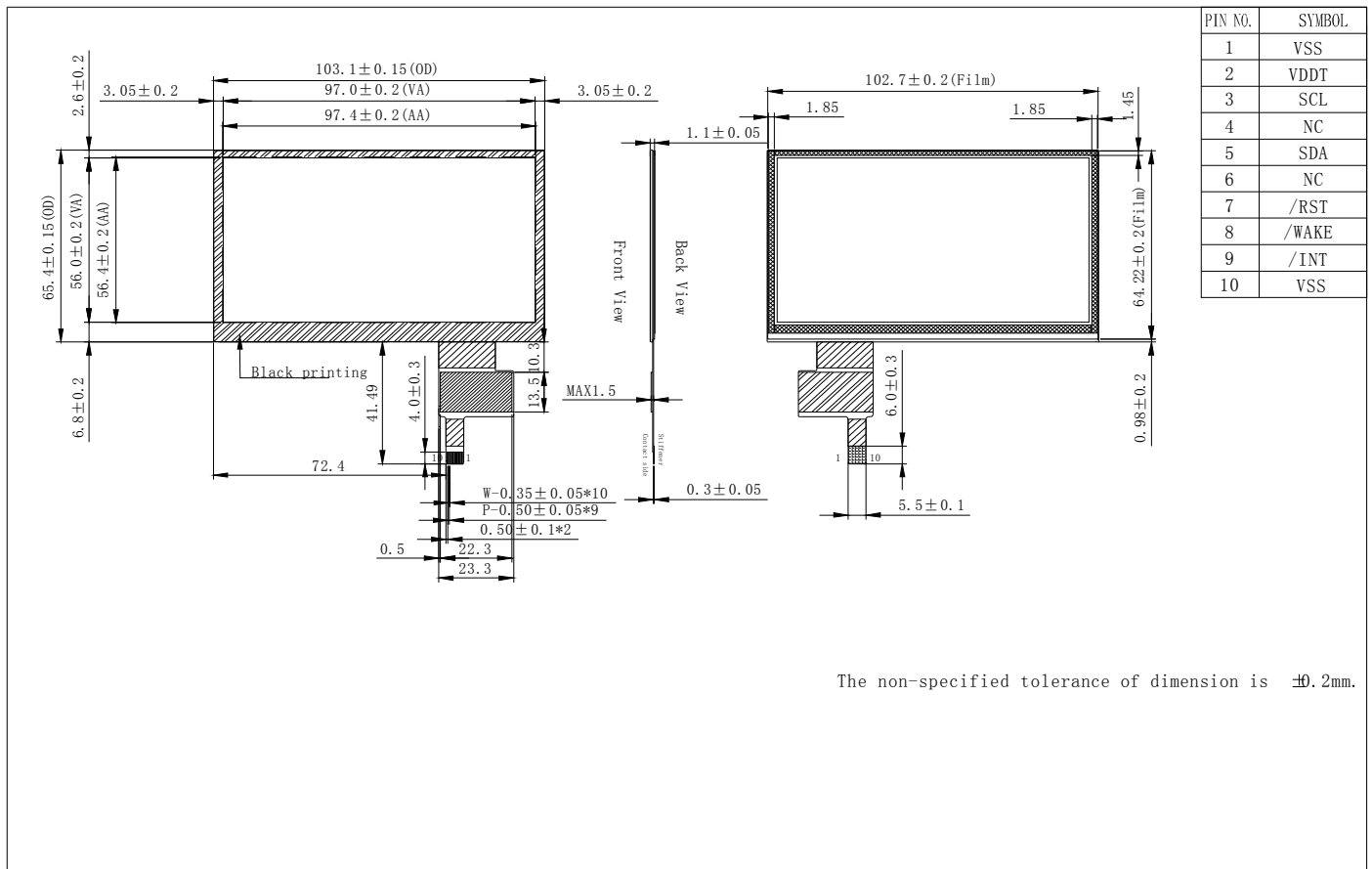

12.1. CTP I2C Timing:

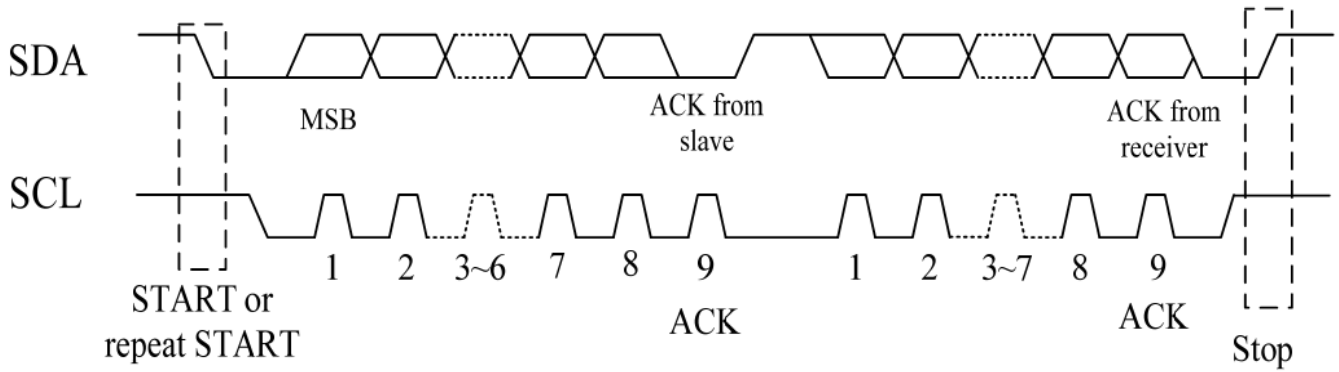

I2C Serial Data Transfer Format

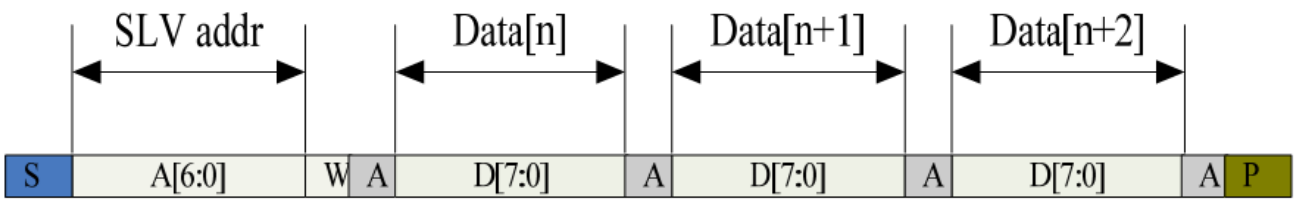

I2C master write, slave read

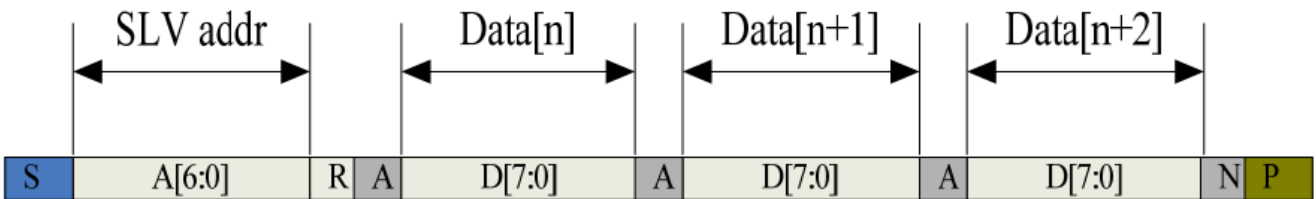

I2C master read, slave write

Mnemonics	Description
S	12C Start or 12C Restart
A[6:0]	Slave address A[6:4]:3'b011 A[3:0]:data bits are identical to those of 12CCON[7:4]register
W	1'b0:Write
R	1'b1:Read
A(N)	ACK(NACK)
P	STOP: the indication of the end of a packet(if this bit is missing, S will indicate the end of the current packet and beginning of the next packet)

Lists the meanings of the mnemonics used in the above figures

Parameter	Unit	Min	Max
SCL frequency	KHz	0	400
Bus free time between a STOP and START condition	us	4.7	\
Hold time (repeated) ST ART condition	us	4.0	\
Data setup time	ns	250	\
Setup time for a repeated START condition	us	4.7	\
Setup time for STOP condition	us	4.0	\

Interface Timing Characteristics

AS FOR STANDARD CTPM, HOST NEED TO USE BOTH INTERRUPT CONTROL SIGNAL AND SERIAL DATA INTERFACE TO GET THE TOUCH DATA.HERE IS THE TIMING TO GET TOUCH DATA.

12.3. TOUCH DATA READ PROTOCOL

NAME	VALUE	DESCRIPTION
START CH	0X00	START COMMAND FOR CTPM TOUCH DATA PACKET,HOST MUST SEND CTPM A START CH COMMAND BEFORE READ TOUCH DATA
Lst READ BYTE ~ LAST READ BYTE		TOUCH DATA PACKET SENT BY CTPM,EACH BYTE HAS 8-BIT DATA ,A TOUCH DATA PACKET CONSISTS OF N BYTE

A DATA PACKET STARTS WITH A HEADER AND ENDS WITH CRC CODE,AS FOR 5 POINTS DATA PACKET,THE LENGTH OF THE PACKET IS ALWAYS 26 BYTES IN SPIE OF ACTUAL TOUCH POINTS.

Address	Name	Bit7	Bit6	Bit5	Bit4	Bit3	Bit2	Bit1	Bit0	Host Access
00h	Devide__Mode		Device Model[2:0]							RW
01h	Gest__ID	Gesture ID[7:0]								R
02h	TD__Status					Number of touch points[3:0]				R
03h	Touch1__XH	1 st Event Flag			1 st Touch X Position[11:8]				R	
04h	Touch1__XL	1 st Touch X Position[7:0]								R
05h	Touch1__YH	1 st Touch ID[3:0]			1 st Touch Y Position[11:8]				R	
06h	Touch1__YL	1 st Touch Y Position[7:0]								R
07h										R
08h										R
09h	Touch2__XH	2 nd Event Flag			2 nd Touch X Position[11:8]				R	
0Ah	Touch2__XL	2 nd Touch X Position[7:0]								R
0Bh	Touch2__YH	2 nd Touch ID[3:0]			2 nd Touch Y Position[11:8]				R	
0Ch	Touch2__YL	2 nd Touch Y Position[7:0]								R
0Dh										R
0Eh										R
0Fh	Touch3__XH	3 rd Event Flag			3 rd Touch X Position[11:8]				R	
10h	Touch3__XL	3 rd Touch X Position[7:0]								R
11h	Touch3__YH	3 rd Touch ID[3:0]			3 rd Touch Y Position[11:8]				R	
12h	Touch3__YL	3 rd Touch Y Position[7:0]								R

13h				R	
14h				R	
15h	Touch4__XH	4thEvent Flag		4thTouch X Position[11:8]	R
16h	Touch4__XL	4th Touch X Position[7:0]		R	
17h	Touch4__YH	4thTouch ID[3:0]		4thTouch Y Position[11:8]	R
18h	Touch4__YL	4th Touch Y Position[7:0]		R	
19h				R	
1Ah				R	
1Bh	Touch5__XH	5thEvent Flag		5thTouch X Position[11:8]	R
1Ch	Touch5__XL	5th Touch X Position[7:0]		R	
1Dh	Touch5__YH	5thTouch ID[3:0]		5thTouch Y Position[11:8]	R
1Eh	Touch5__YL	5th Touch Y Position[7:0]		R	