

**DISPLAY Elektronik GmbH**

# DATA SHEET

**LCD MODULE**

**DEM 320240G FGH-PW**

*Product Specification*

*Version: 10*

**21/Dec/2016**

# GENERAL SPECIFICATION

---

MODULE NO. :

# DEM 320240G FGH-PW

CUSTOMER P/N

Version No.	Change Description	Date
0	Original Version	15.03.2010
1	Update Product Specification	30.03.2010
2	Update Module And Backlight Drawing	08.04.2010
3	Change Module Drawing	13.04.2010
4	Change LCD Voltage	25.06.2010
4.1.3	Low current version	24.08.2011
5	Add Test Adjunct	07.03.2014
6	Add Version	14.04.2014
7	Change Module Drawing	05.05.2014
8	Delete Chapter	20.05.2014
9	Change Power Supply Voltage	26.02.2016
10	Change Module Drawing	21.12.2016

PREPARED BY: LT

DATE: 21.12.2016

APPROVED BY: MHO

DATE: 21.12.2016

**CONTENTS**

**1. FUNCTIONS & FEATURESS.....2**

**2. MECHANICAL SPECIFICATIONS .....2**

**3. EXTERNAL DIMENSIONS .....3**

**4. BLOCK DIAGRAM .....4**

**5. PIN ASSIGNMENT .....4**

**6. BACKLIGHT DRAWING.....5**

**7. MAXIMUM ABSOLUTE LIMIT.....6**

**8. POWER SUPPLY.....6**

**9. JUMPER SETTING .....6**

**10. ELECTRICAL CHARACTERISTICS.....7**

**11. INSTRUCTION SET .....10**

**12. OPTICAL CHARACTERISTICS ..... 11**

**13. LCD MODULES HANDLING PRECAUTIONS .....12**

**14. OTHERES.....12**

**1. FUNCTIONS & FEATURESS**

Module Model	LCD Type	Remark
DEM 320240G FGH_PW	FSTN Transflective Positive Mode	Paper white polarizer

- Viewing Direction : 6 O'clock
- Driving Scheme : 1/240 Duty Cycle, 1/17 Bias
- Display Content : 320 x 240 Dots
- Power Supply Voltage : TYP: 3.3 Volt (typ.) / 5.0 Volt (typ.)
- LCD Driving Voltage : 14.4 Volt (typ.)
- LCD-Controller : RA8835 (Raio)
- Backlight Color : Paper White
- RoHS : Compliance

**2. MECHANICAL SPECIFICATIONS**

- Module Size(Without FFC) : 93.30 x 73.00 x 6.70 mm
- Viewing Area : 81.80 x 62.00 mm
- Active Area : 76.785 x 57.585 mm
- Dot Size : 0.225 x 0.225 mm
- Dot Pitch : 0.24 x 0.24 mm

3. EXTERNAL DIMENSIONS

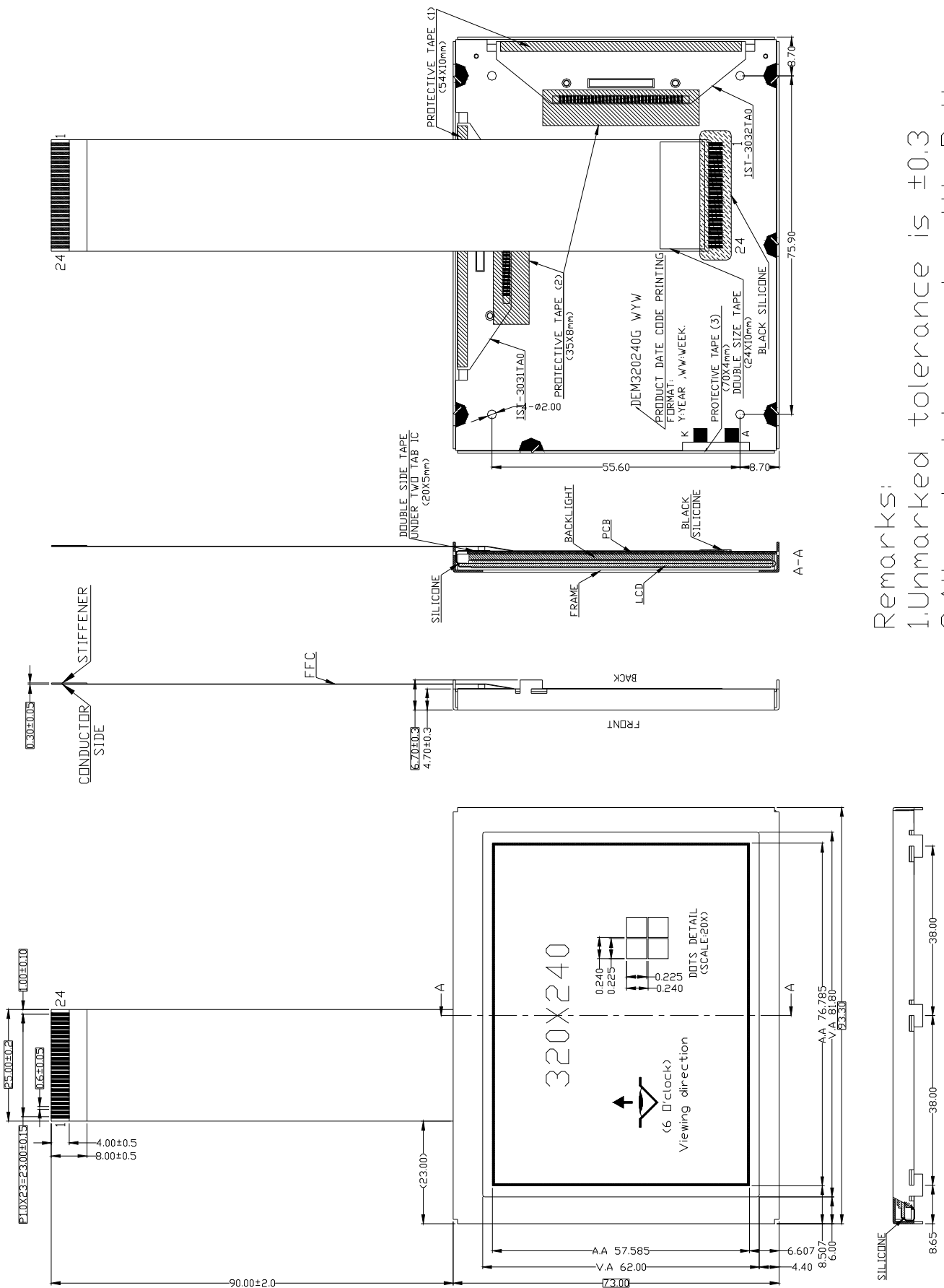

Remarks:  
 1. Unmarked tolerance is ±0.3  
 2. All materials comply with RoHS  
 3.  ...:critical dimension.

**4. BLOCK DIAGRAM**

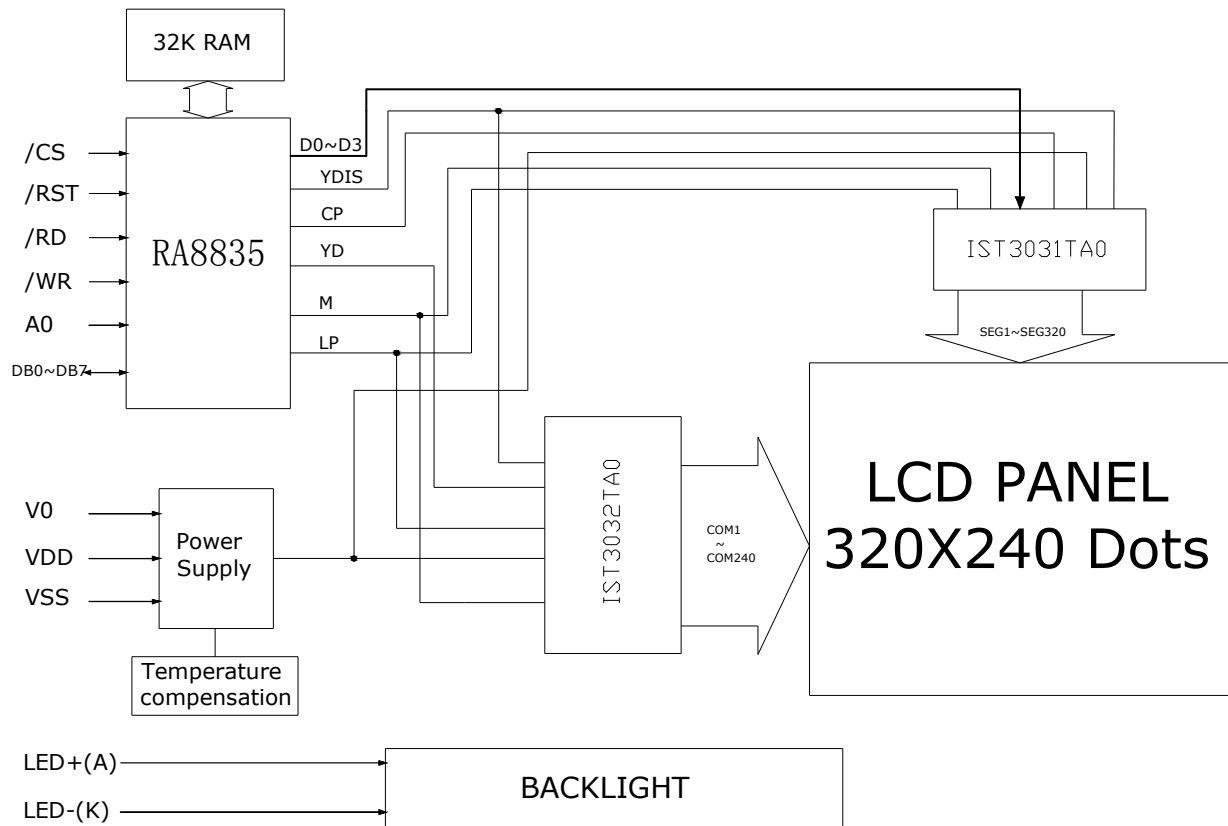

**5. PIN ASSIGNMENT**

Pin No.	Symbol	Function
1	/RST	Reset signal
2	/RD	8080 family: Read signal; 6800 family: Enable clock (E)
3	/WR	8080family: Write signal; 6800 family: R/W signal
4	/CS	Chip select
5	A0	Data type select, H: Data register; L: Command register
6~13	DB0~DB7	Data bus
14	VDD	Power supply of module
15	VSS	Ground
16	V0	Contrast voltage for LCD drive (typ.: 0.5v)
17~22	NC	No used
23	LED+(A)	Anode for backlight
24	LED-(K)	Cathode for backlight

6. BACKLIGHT DRAWING

Item	Symbol	min.	typ.	max.	Unit	Condition
Forward Voltage	Vf	2.8	3.2	3.5	V	If= 90 mA
Power Dissipation	Pd	-	-	297	mW	If= 90 mA
Luminous Uniformity	$\Delta Lv$	70			%	MIN/MAX*100%
Luminance	Lv	85	120		cd/m <sup>2</sup>	If= 90 mA T=25°C
Color Coordinate	X	0.27		0.34		
	Y	0.27		0.34		
Peak wave length	$\lambda P$	-	-	-	nm	

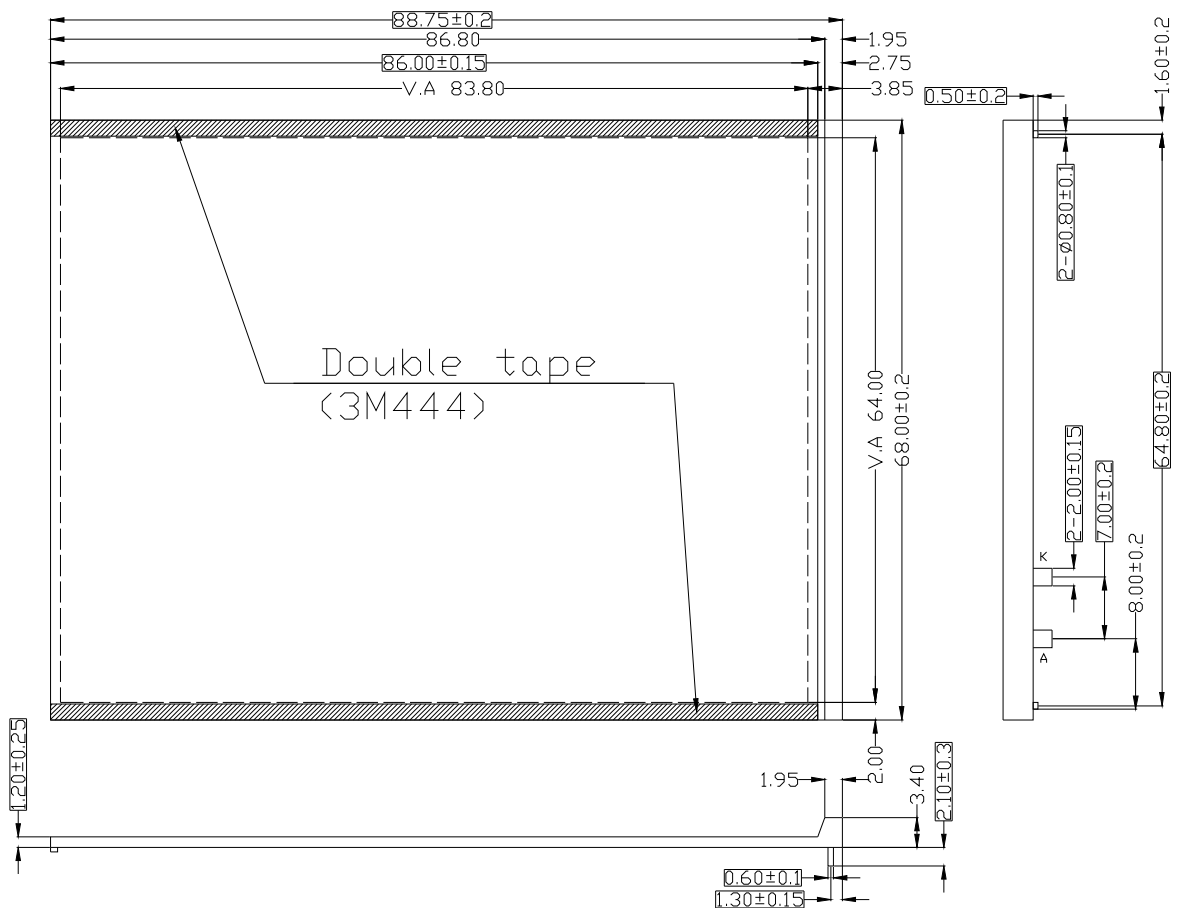

Remarks:

1. Unmarked tolerance is  $\pm 0.2$
2. All materials comply with RoHs
3.   ...:critical dimension.
4. LED Life time 30000 hrs

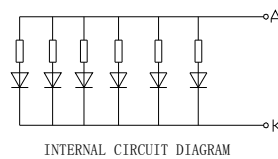

**7. MAXIMUM ABSOLUTE LIMIT**

Item	Symbol	Standard value	Unit
Supply voltage range	$V_{DD}$	-0.3~+6.5	V
Input voltage range	$V_{IN}$	-0.3~ $V_{DD}+0.3$	V
Power supply for liquid crystal drive	$V_{DDH}$	-0.3 ~ +26	V
Operating temperature range	$T_{opr}$	-20 ~ +70	°C
Storage temperature range	$T_{stg}$	-30 ~ +80	°C

**8. POWER SUPPLY**

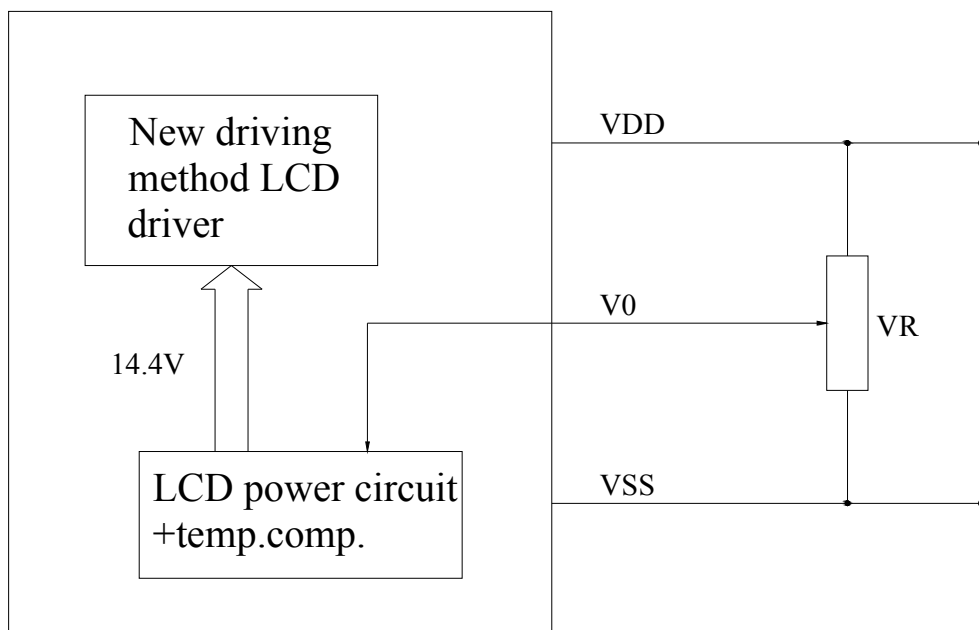

**9. JUMPER SETTING**

Item	Option	Jumper setting	Remark
MPU	8080 family (default)	Pin1,2 short on JP4	-
	6800 family	Pin 2,3 short on JP4	-



**10. ELECTRICAL CHARACTERISTICS**

**10-1 DC Characteristics**

Item	Symbol	Standard Value			Test Condition	Unit
		MIN	TYP	MAX		
Power supply for logic	$V_{DD}$	2.4	3.3 5.0	5.5	$V_{DD}-V_{SS}$	V
Supply current for logic	$I_{DD}$	--	15	22.5	$V_{DD}=3.3V$	mA
Power supply for LCD	$V_{OP}$	--	15.8	--	$-20^{\circ}C$	V
		--	15.1	--	$0^{\circ}C$	V
		--	14.4	--	$25^{\circ}C$	V
		--	13.7	--	$50^{\circ}C$	V
		--	12.7	--	$70^{\circ}C$	V
Input voltage	$V_{IH}$	$0.8V_{DD}$	-	$V_{DD}$	-	V
	$V_{IL}$	$V_{SS}$	-	$0.2V_{DD}$	-	V

**10-2. AC Characteristics**

**10-2-1. 8080 Family Interface Timing**

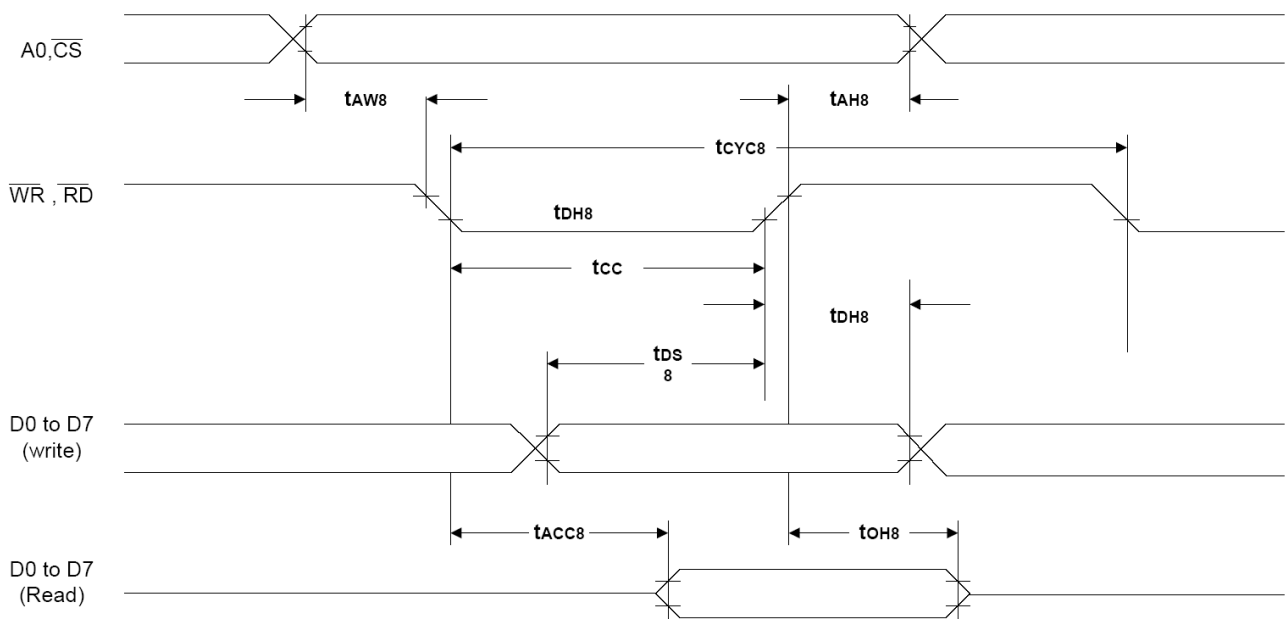

Ta=25°C

Signal	Symbol	Parameter	V <sub>DD</sub> = 4.5 to 5.5V		V <sub>DD</sub> = 2.7 to 4.5V		Unit	Condition
			Min.	Max.	Min.	Max.		
A0, $\overline{\text{CS}}$	t <sub>AH8</sub>	Address hold time	10	—	10	—	ns	CL = 100pF
	t <sub>AW8</sub>	Address setup time	0	—	0	—	ns	
$\overline{\text{WR}}$ , $\overline{\text{RD}}$	t <sub>CYC8</sub>	System cycle time	note.	—	note.	—	ns	
	t <sub>CC</sub>	Strobe pulse width	120	—	150	—	ns	
D0 to D7	t <sub>DS8</sub>	Data setup time	120	—	120	—	ns	
	t <sub>DH8</sub>	Data hold time	5	—	5	—	ns	
	t <sub>ACC8</sub>	$\overline{\text{RD}}$ access time	—	50	—	80	ns	
	t <sub>OH8</sub>	Output disable time	10	50	10	55	ns	

10-2-2. 6800 Family Interface timing

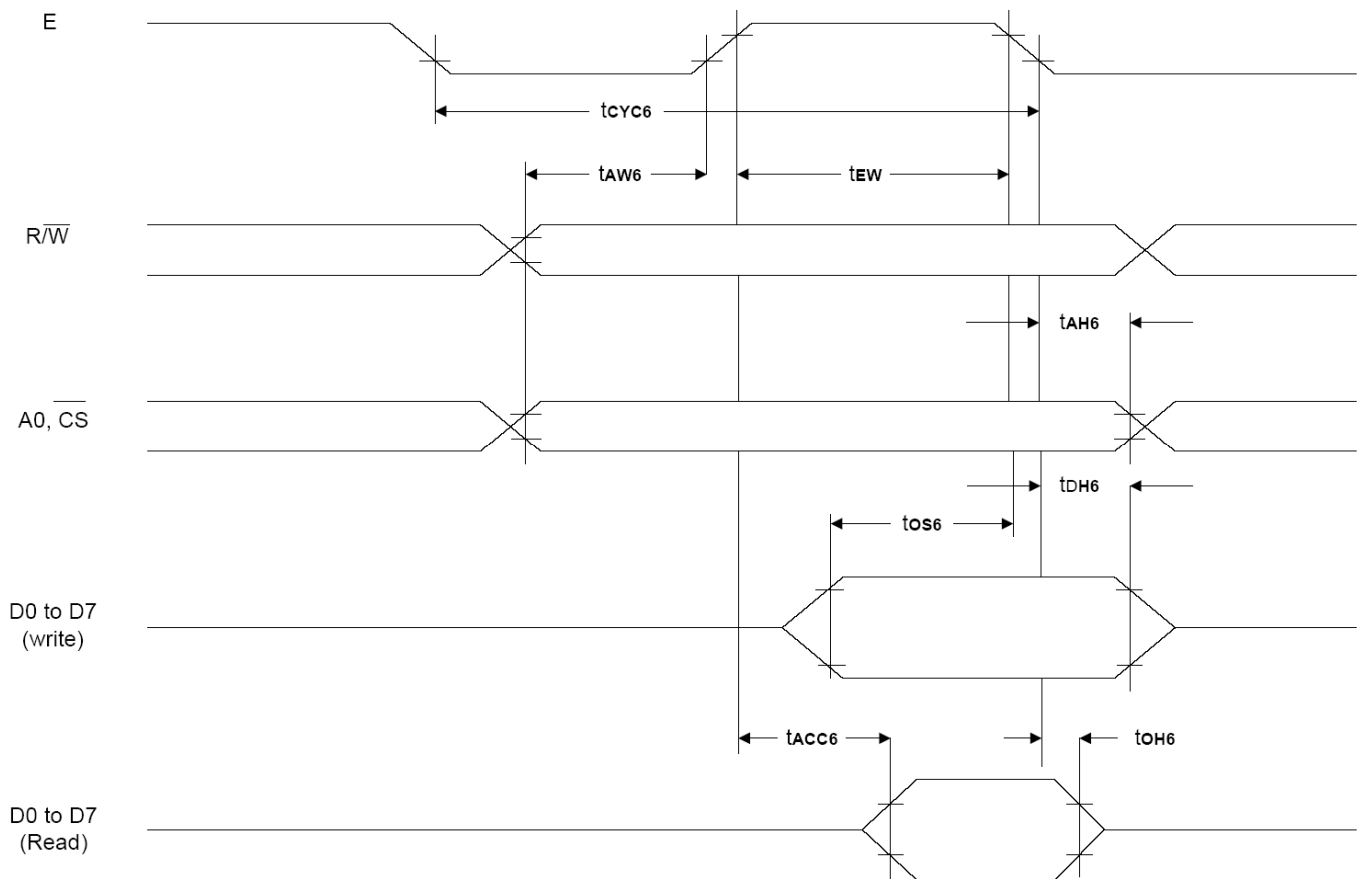

Ta=25°C

Signal	Symbol	Parameter	V <sub>DD</sub> = 4.5 to 5.5V		V <sub>DD</sub> = 2.7 to 4.5V		Unit	Condition
			Min.	Max.	Min.	Max.		
A0, $\overline{\text{CS}}$ , R/(W)	t <sub>CYC6</sub>	System cycle time	note.	—	note.	—	ns	CL = 100 pF
	t <sub>AW6</sub>	Address setup time	0	—	10	—	ns	
	t <sub>AH6</sub>	Address hold time	0	—	0	—	ns	
D0 to D7	t <sub>DS6</sub>	Data setup time	100	—	120	—	ns	
	t <sub>DH6</sub>	Data hold time	0	—	0	—	ns	
	t <sub>OH6</sub>	Output disable time	10	50	10	75	ns	
	t <sub>ACC6</sub>	Access time	—	85	—	130	ns	
E	t <sub>EW</sub>	Enable pulse width	120	—	150	—	ns	

10-2-3. Sleep In Command Timing

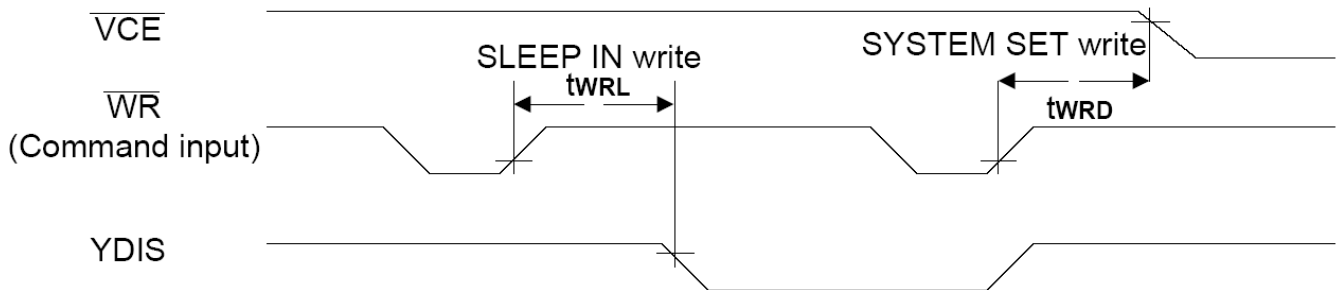

Ta=25°C

Signal	Symbol	Parameter	V <sub>DD</sub> = 4.5 to 5.5V		V <sub>DD</sub> = 2.7 to 4.5V		Unit	Condition
			Min.	Max.	Min.	Max.		
$\overline{\text{WR}}$	t <sub>WRD</sub>	VCE falling-edge delay time	note 1.	—	note 1.	—	ns	CL = 100 pF
	t <sub>WRL</sub>	YDIS falling-edge delay time	—	note 2.	—	note 2.	ns	

11. INSTRUCTION SET

The Command Set

Class	Command	Code											Hex	Command Description	Command Read Parameters	
		RD	WR	A0	D7	D6	D5	D4	D3	D2	D1	D0			No. of Bytes	Section
System Control	SYSTEM SET	1	0	1	0	1	0	0	0	0	0	0	40	Initialize device and display	8	9-2-1
	SLEEP IN	1	0	1	0	1	0	1	0	0	1	1	53	Enter standby mode	0	9-2-2
Display Control	DISPLAY ON/OFF	1	0	1	0	1	0	1	1	0	0	D	58, 59	Enable and disable display and display flashing	1	9-3-1
	SCROLL	1	0	1	0	1	0	0	0	1	0	0	44	Set display start address and display regions	10	9-3-2
	CSRFORM	1	0	1	0	1	0	1	1	1	0	1	5D	Set cursor type	2	9-3-3
	CGRAM ADR	1	0	1	0	1	0	1	1	1	0	0	5C	Set start address of character generator RAM	2	9-3-6
	CSRDIR	1	0	1	0	1	0	0	1	1	CD 1	CD 0	4C to 4F	Set direction of cursor movement	0	9-3-4
	HDOT SCR	1	0	1	0	1	0	1	1	0	1	0	5A	Set horizontal scroll position	1	9-3-7
	OVLAY	1	0	1	0	1	0	1	1	0	1	1	5B	Set display overlay format	1	9-3-5
Drawing Control	CSRW	1	0	1	0	1	0	0	0	1	1	0	46	Set cursor address	2	9-r1
	CSRR	1	0	1	0	1	0	0	0	1	1	1	47	Read cursor address	2	9-4-2
Memory Control	MWRITE	1	0	1	0	1	0	0	0	0	1	0	42	Write to display memory	—	9-5-1
	MREAD	1	0	1	0	1	0	0	0	0	1	1	43	Read from display memory	—	9-5-2

Notes:

1. In general, the internal registers of the RA8835A series are modified as each command parameter is input. However, the microprocessor does not have to set all the parameters of a command and may send a new command before all parameters have been input. The internal registers for the parameters that have been input will have been changed but the remaining parameter registers are unchanged. 2-byte parameters (where two bytes are treated as 1 data item) are handled as follows:

- a. CSRW, CSRR: Each byte is processed individually. The microprocessor may read or write just the low byte of the cursor address.
- b. SYSTEM SET, SCROLL, CGRAM ADR: Both parameter bytes are processed together. If the command is changed after half of the parameter has been input, the single byte is ignored.

2. APL and APH are 2-byte parameters, but are treated as two 1-byte parameters.

**12. OPTICAL CHARACTERISTICS**

Item	Symbol	Condition	MIN	TYP	MAX	Unit	Note
Viewing angle	$\theta_f$	25°C & C $\geq$ 2		35		degree	
	$\theta_b$			25			
	$\theta_l$			40			
	$\theta_r$			30			
Contrast ratio	C	25°C		9		-	
Rising time	tr	25°C		190	285	ms	
Falling time	tf	25°C		350	525	ms	
Frame frequency	fF	25°C		70		Hz	

**NOTE1: DEFINITION OF RESPONSE TIME**

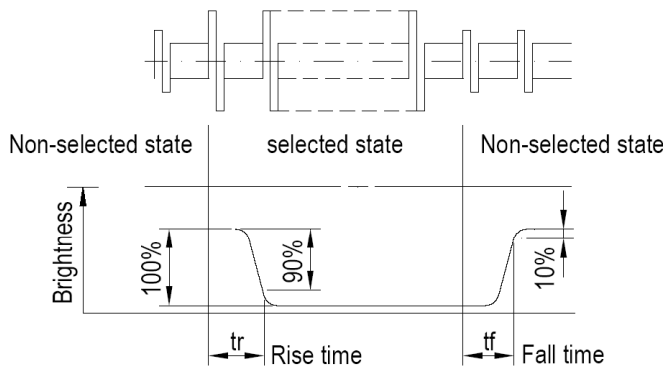

**NOTE2: DEFINITION OF ANGLES  $\theta$  AND  $\phi$**

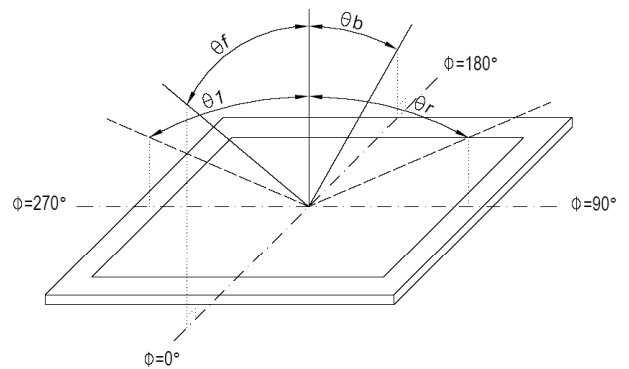

**NOTE3: DEFINITION OF CONTRAST RATIO C**

$$C = \frac{\text{Brightness of selected dot (B1)}}{\text{Brightness of unselected dot (B2)}}$$

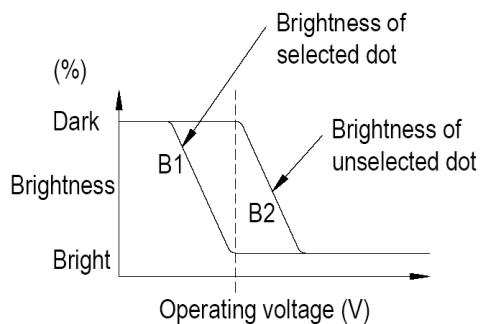

**NOTE4: DEFINITION OF VIEWING ANGLES  $\theta_1$  AND  $\theta_2$**

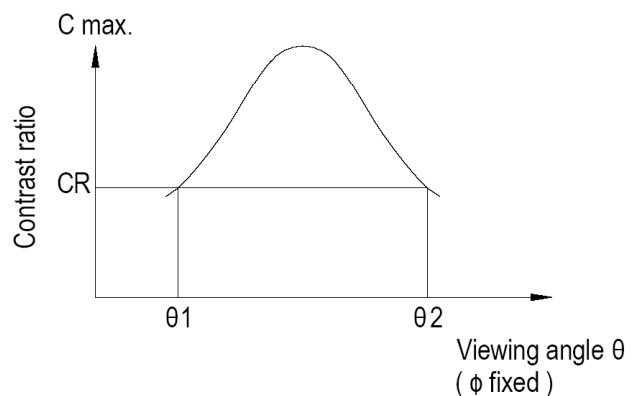

**13. LCD MODULES HANDLING PRECAUTIONS**

- The display panel is made of glass. Do not subject it to a mechanical shock by dropping it from a high place, etc.
- If the display panel is damaged and the liquid crystal substance inside it leaks out, do not get any in your mouth. If the substance come into contact with your skin or clothes promptly wash it off using soap and water.
- Do not apply excessive force to the display surface or the adjoining areas since this may cause the color tone to vary.
- The polarizer covering the display surface of the LCD module is soft and easily scratched. Handle this polarize carefully.
- To prevent destruction of the elements by static electricity, be careful to maintain an optimum work environment.
  - Be sure to ground the body when handling the LCD module.
  - Tools required for assembly, such as soldering irons, must be properly grounded.
  - To reduce the amount of static electricity generated, do not conduct assembly and other work under dry conditions.
  - The LCD module is coated with a film to protect the display surface. Exercise care when peeling off this protective film since static electricity may be generated.
- Storage precautions  
When storing the LCD modules, avoid exposure to direct sunlight or to the light of fluorescent lamps. Keep the modules in bags designed to prevent static electricity charging under low temperature / normal humidity conditions (avoid high temperature / high humidity and low temperatures below 0°C).Whenever possible, the LCD modules should be stored in the same conditions in which they were shipped from our company.

**14. OTHERES**

- Liquid crystals solidify at low temperature (below the storage temperature range) leading to defective orientation of liquid crystal or the generation of air bubbles (black or white). Air bubbles may also be generated if the module is subjected to a strong shock at a low temperature.
- If the LCD modules have been operating for a long time showing the same display patterns may remain on the screen as ghost images and a slight contrast irregularity may also appear. Abnormal operating status can be resumed to be normal condition by suspending use for some time. It should be noted that this phenomena does not adversely affect performance reliability.
- To minimize the performance degradation of the LCD modules resulting from caused by static electricity, etc. exercise care to avoid holding the following sections when handling the modules:
  - Exposed area of the printed circuit board
  - Terminal electrode sections