

Display Elektronik GmbH

DATA SHEET

TFT MODULE

DEM 240240A VMH-PW-N

1,54" TFT

Product Specification

Ver.: 0

31.05.2018

Revise Records

Rev.	Date	Contents	Written	Approved
0	31.05.2018	Preliminary Specification	R	MHI

Special Notes

Note1.	
Note2.	
Note3.	
Note4.	
Note5.	

Contents

- 1. General Description and Features..... 4**
 - 1.1. Features 4
 - 1.2. LCD Module 4
- 2. Mechanical Information 4**
- 3. Electrical Specifications..... 5**
 - 3.1 Absolute Max. Ratings 5
 - 3.2 Electrical Absolute Rating 5
- 4. Electrical Characteristics 5**
 - 4.1. TFT-LCD Module 5
 - 4.2. Backlight Unit 6
- 5. Input Terminal Pin Assignment 7**
 - 5.1. Pin Assignment (LCD) 7
- 6. Optical Characteristics..... 8**
- 7. Reliability Condition 11**
- 8. DIMANSIONAL OUTLINE 12**
- 9. Incoming Inspection Standards 13**

1. General Description and Features

This TFT is a color active matrix LCD module incorporating amorphous silicon TFT (Thin Film Transistor). It is composed of a color TFT-LCD panel, driver IC, FPC and a back light unit. The module display area contains 240x240 pixels and can display up to 262K colors.

1.1. Features

- 240 x 240 pixels resolution.
- Display in 262k colors.
- SPI Interface
- RoHS Compliance

1.2. LCD Module

Item	Specification	Unit
Screen Size	1.54 Inches	Diagonal
Display Resolution	240 x RGB x 240	Dot
Active Area	27.72 x 27.72	mm
Outline Dimension	31.50 x 35.00 x 2.30	mm
Display Mode	IPS	--
Pixel Arrangement	RGB Stripe	--
Pixel Size	0.1155 x 0.1155	mm
Surface Treatment	Anti-Glare	--
Display Color	262k	--
Viewing Direction	IPS	--
Input Interface	4-Wire-SPI	--

2. Mechanical Information

Item		Min.	Typ.	Max.	Unit	Note
Module Size	Horizontal (H)	31.30	31.50	31.70	mm	--
	Vertical (V)	34.80	35.00	35.20	mm	
	Thickness (T)	2.20	2.30	2.40	mm	(1)
Weight		--	TBD	--	g	--

Note (1) Not include Component.

Refer to the Outline Dimension for further information.

3. Electrical Specifications

3.1 Absolute Max. Ratings

3.1.1 Absolute Ratings of Environment

If the operating condition exceeds the following absolute maximum ratings, the TFT LCD module may be damaged permanently. (Ta=25±2°C, VSS=GND=0)

Item	Symbol	Min.	Max.	Unit	Note
Storage Temperature	T _{STG}	-30	80	°C	(1)
Operating Temperature	T _{OPR}	-20	70	°C	(1,2,3)

Note (1) 90 % RH Max. (40 °C ≥ Ta). Maximum wet-bulb temperature at 39 °C or less. (Ta > 40°C) No condensation.

Note (2) In case of below 0°C, the response time of liquid crystal (LC) becomes slower and the color of panel becomes darker than normal one. Level of retardation depends on temperature, because of LC's character

Note (3) Only operation is guaranteed at operating temperature. Contrast, response time, another display quality are evaluated at +25°C.

3.2 Electrical Absolute Rating

The following are maximum values which, if exceeded, may cause faulty operation or damage to the unit.

(VSS=GND=0)

Item	Symbol	Min.	TYP	max	Unit	Note
Interface Operation Voltage	IOVCC	1.65v	+1.8v	+3.3v	V	
Input Current	IOICC	-	6.0	-	mA	

4. Electrical Characteristics

4.1. TFT-LCD Module

ITEM	SYMBOL	MIN	TYP	MAX	UNIT	NOTE
System Voltage	V _{CC}	2.4	2.8	3.3	V	
Input Current	I _{CC}	-	6.0	7.5	mA	
Input voltage ' H ' level	V _{IH}	0.7V _{CC}	-	V _{CC}	V	
Input voltage ' L ' level	V _{IL}	V _{SS}	0	0.3V _{CC}	V	
Output voltage ' H ' level	V _{OH}	0.8 V _{CC}	--	V _{CC}	V	
Output voltage ' L ' level	V _{IL}	0	0	0.2V _{CC}	V	

Operation Mode	Image	Current Consumption			
		Typical		Maximum	
		IOICC (mA)	ICC (mA)	IOICC (mA)	ICC (mA)
Normal Mode	Black	0.005	6.0	0.01	7.5

TYPICAL: IOVCC=1.8V, VCC=2.75V; MAXIMUM: IOVCC=1.65 TO 3.3V, VCC=2.4 TO 3.3V

4.2. Backlight Unit

(Ta=25±2°C)

Item	Symbol	Value			Unit	Note
		Min.	Typ.	Max.		
LED Total Input Voltage	V _L	2.8	3	3.2	V	
LED Total Input Current	I _L	-	45	-	mA	(1)
Power Consumption	P _{BL}	-	135	144	mW	(2)
Lifetime	-	35000	50000	-	Hrs	(3)

Note (1) Circuit diagram

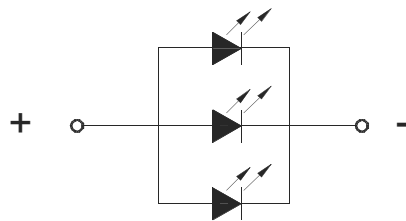

(2) Where $I_L = 45\text{mA}$, $V_L = 3$, $P_{BL} = V_B \times I_B$

(3) The environmental conducted under ambient air flow at $T_a=25^\circ\text{C} \pm 2^\circ\text{C}$, $60\%\text{RH} \pm 5\%$

5. Input Terminal Pin Assignment

5.1. Pin Assignment (LCD)

Pin No.	Symbol	Function	Remark
1	LEDK	Backlight power supply negative	
2	LEDK	Backlight power supply negative	
3	GND	Ground	
4	GND	Ground	
5	FMARK	Synchronies MCU to frame rate	
6	SDA	4w serial interface SDA	
7	WR(SCL)	4w serial interface SCL	
8	RS(D/C)	4w serial interface D/C	
9	CS	4w serial interface CS	
10	RESET	-This signal will reset the device and it must be applied to properly initialize the chip.	
11	IOVCC	Power supply to interface pins (TYP 1.8V or 2.8V)	
12	IOVCC	Power supply to interface pins (TYP 1.8V or 2.8V)	
13	VCC	Power supply(TYP 2.8V)	
14	VCC	Power supply(TYP 2.8V)	
15	GND	Ground	
16	GND	Ground	
17	NC	NC	
18	NC	NC	
19	NC	NC	
20	NC	NC	
21	NC	NC	
22	NC	NC	
23	LEDA	Backlight power supply positive	
24	LEDA	Backlight power supply positive	

6. Optical Characteristics

Item	Symbol	Condition	Min	Type	Max	Unit	Note	
Brightness	B		320	400	--	cd/m ²		
Response Time (White - Black)	Tr +Tf	$\theta=0^\circ$	--	30	40	ms		
Contrast ratio	CR	At optimized viewing angle	300	500	--	--		
Luminance Uniformity	ΔL		80	85		%		
Color Chromaticity (CIE 1931)	White	Wx	$\theta=0^\circ$	0.273	0.313	0.353	--	BM-7A
		Wy	Normal Viewing Angle	0.289	0.329	0.369		
Viewing Angle	Ver.	θ_U	CR \geq 10	--	80	--	Degree	
		θ_D		--	80	--		
	Hor.	θ_R		--	80	--		
		θ_L		--	80	--		

a. Test equipment setup

After stabilizing and leaving the panel alone shall be warmed up for the stable operation of LCM, the measurement should be executed. Measurement should be executed in a stable, windless, and dark room. Optical specifications are measured by Topcon BM-7(fast) with a viewing angle of 1° at a distance of 50cm and normal direction.

b. Definition of response time: Tr and Tf

The response time is defined as the following figure and shall be measured by switching the input signal for "black" and "white".

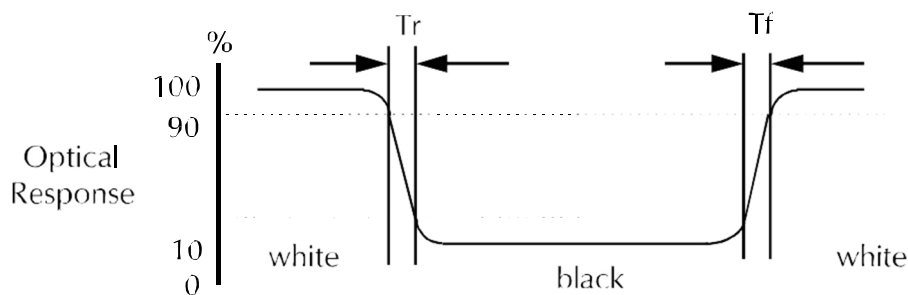

c. Definition of contrast ratio:

Brightness measured when LCD is at "white state"

Contrast Ratio (CR) =

Brightness measured when LCD is at "black state"

- d. Measured at the center area of the panel when all the input terminals of LCD panel are electrically opened.
- e. View Angle

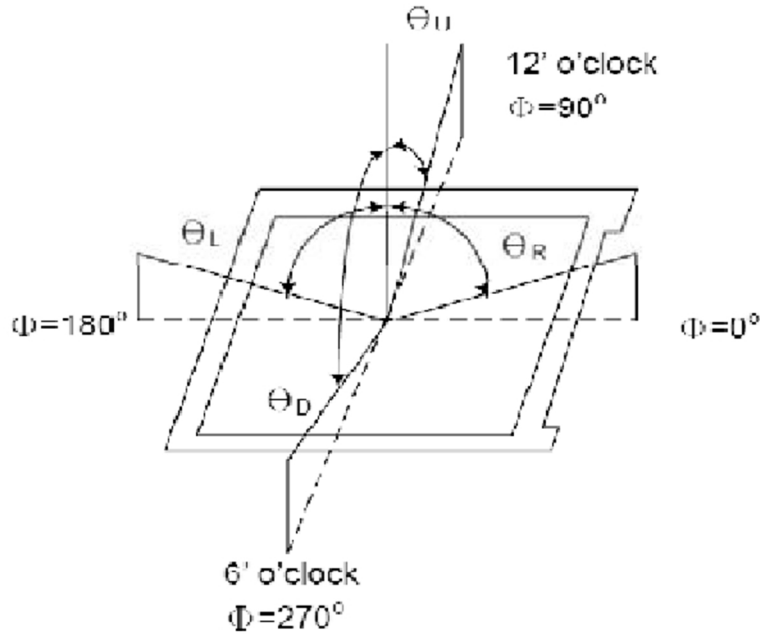

- f. Definition of Luminance of White: Luminance of white at the center points

Light Source of Back-Light Unit	LED Type
---------------------------------	----------

- g. Definition of White Uniformity

$$\text{White Uniformity} = \frac{\text{Min. luminance of white among 9-points}}{\text{Max. luminance of white among 9-points}} \times 100\%$$

- h. The definition of Color Gamut -Color Chromaticity CIE 1931

Color coordinate of white & red, green, blue at center point.

Color Gamut : NTSC(%) = (RGB Triangle Area / NTSC Triangle Area) x 100

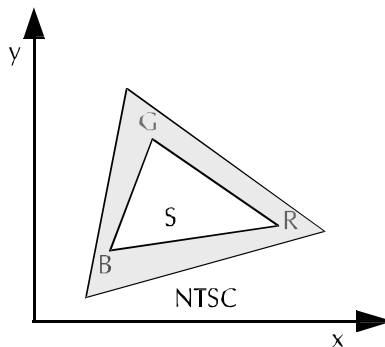

7. Reliability Condition

No change on display and in operation under the following test condition.

Condition: Unless otherwise specified, tests will be conducted under the following condition.

Temperature: 20°C ± 5°C

Humidity: 65%RH ± 5%

Tests will be not conducted under functioning state.

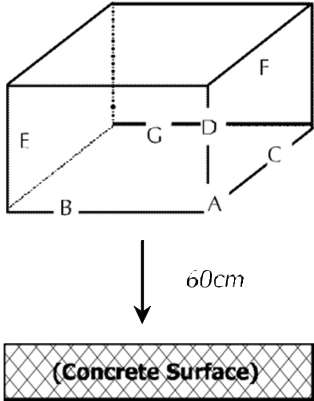
No.	Parameter	Condition	Notes
1	High Temperature Operating	+70°C±2°C, 120hrs (Operation state).	
2	Low Temperature Operating	-20°C±2°C, 120hrs (Operation state).	1
3	High Temperature Storage	+80°C±2°C, 120hrs.	2
4	Low Temperature Storage	-30°C±2°C, 120hrs.	1,2
5	High Temperature and High Humidity Operation Test	+60°C±2°C, 90%, 120hrs.	1,2
6	Vibration Test	Total fixed amplitude: 1.5mm. Vibration Frequency: 10~55Hz. One cycle 60 seconds to 3 direction of X, Y, Z each 15 minutes.	3
7.	Drop Test	To be measured after dropping from 60cm high on the concrete surface in packing state.  <i>Dropping method corner dropping:</i> <i>A corner: Once edge dropping.</i> <i>B, C, D edge: Once face dropping.</i> <i>E, F, G face: Once.</i>	

- Notes:
1. No dew condensation to be observed.
 2. The function test shall be conducted after 4 hours storage at the normal temperature and humidity after removed from the test chamber.
 3. Vibration test will be conducted to the product itself without putting I in a container.

8. DIMANSIONAL OUTLINE

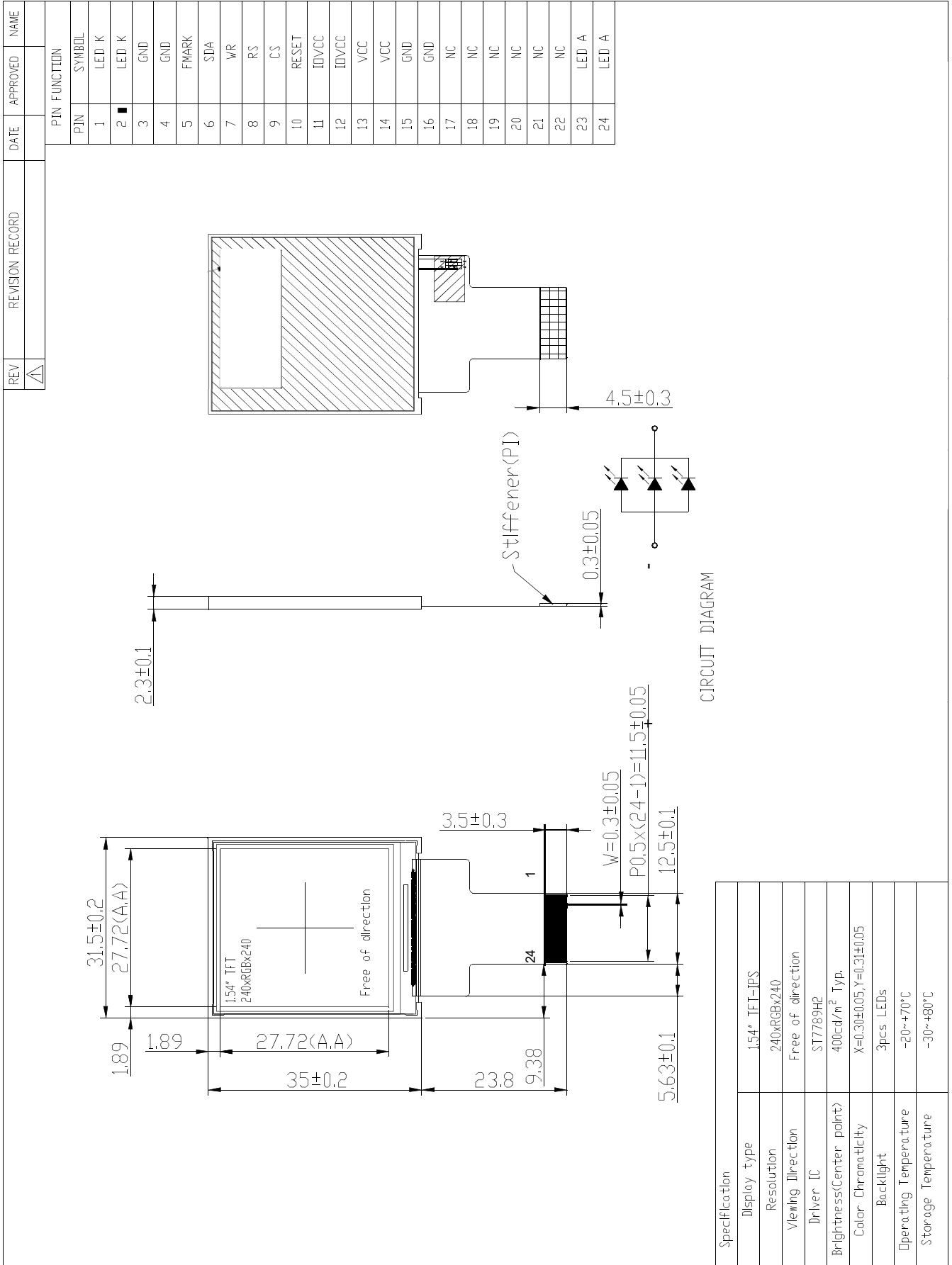

9. Incoming Inspection Standards

9.1. Inspection and Environment Conditions

9.1.1. Inspection Conditions:

- (1) Inspection Distance: 35 cm±5cm
- (2) View Angle : Light-on Inspection Angle : ±5°

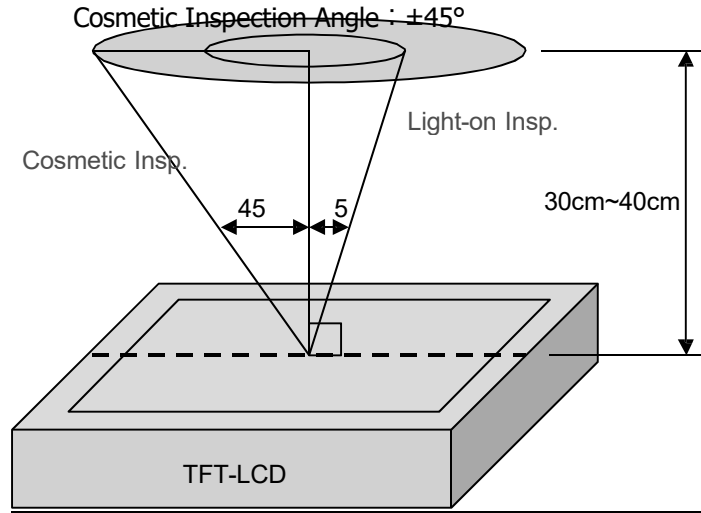

(perpendicular to LCD panel surface)

9.1.2. Environment Conditions:

Ambient Temperature		23°C±5°C
Ambient Humidity		55%±10%RH
Ambient Illumination	Cosmetic Inspection	more than 600 Lux
	Functional Inspection	300~500 Lux

9.1.3. Sampling Conditions:

- (1) Lot Size: Quantity of shipment lot per model
- (2) Sampling Method:

Sampling Plan		MIL-STD-105E
		Normal Inspection, Single Sampling Level II
AQL	Major Defect	1.0%
	Minor Defect	1.5%

- (3) The classification of Major (MA) and Minor (MI) defects is shown as 3. Inspection Criteria.

9.1.4. Inspection Criteria

9.1.4.1. Cosmetic Inspection(Panel):

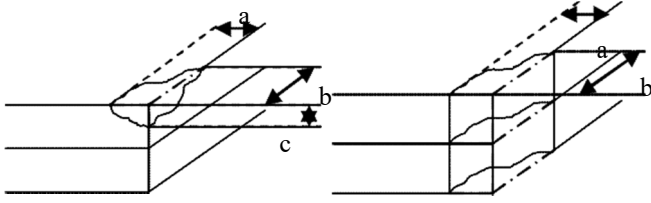
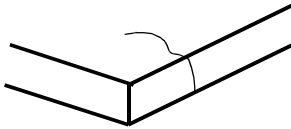
Item	Judgment Criteria	Classification
Chipping on Panel	 <p>$a \leq 3.0\text{mm}$, $b \leq 3.0\text{mm}$, $c \leq t$ (Bottom glass thickness)</p>	MA
Scratch on Panel *Note-2	<p>$W \leq 0.05\text{mm}$ or $L < 5\text{mm}$: Ignored</p> <p>$0.05\text{mm} < W \leq 0.1\text{mm}$ and $L \leq 5\text{mm}$: $N \leq 5$</p>	MI
Bubble or Dent on Panel *Note-3	<p>$D \leq 0.2\text{mm}$: Ignored</p> <p>$0.2\text{mm} < D \leq 0.3\text{mm}$: $N \leq 5$</p>	MI
Panel Crack	 <p>Not Allowed crack</p>	MA
Bezel Deformation	Obvious deformation is not allowed.	MI
Bezel Oxidation	Not allowed if it rusts continuously over 1 cm (It is out of warranty with rusted tin plate)	MI
Bezel Scratch	$L \leq 20\text{mm}$, $W \leq 0.2$, $N \leq 3$	MI
Metal Squash Dent /Flange(Front Side)	$D(W) \leq 1, L \leq 3, N \leq 3$;	MI
B/L High Voltage Wire Denudation	Not allowed	MA
Polarizer flaw or leak out resin	Defect is defined as the active area.	MI
Outline Dimension	Must in Spec, refer to related product spec.	MI

9.1.4.3. Functional Inspection:

Item	Judgment Criteria			Classification
	Area(Note1)	I	O	
Point Defect	Bright dot	Random	1	
		2 dots adjacent	0	0
		3 dots adjacent or more	0	0
	Dark dot	Random	2	
		2 dots adjacent	0	
		3 dots adjacent or more	0	0
	Total Dot Defect		3	
	Distance	Distance between Bright and Bright dot	$L \geq 5\text{mm}$	
		Distance between Bright and Dark dot	$L \geq 5\text{mm}$	
		Distance between Dark dot	$L \geq 5\text{mm}$	
(1) It is defined as Point Defect if defect area $> 0.5\text{dot}$ (2) It is ignored if defect area $\leq 0.5\text{dot}$ (3) Weak point defect will be defined as Bright Dot if it can be observed through ND filter 5% (Full Screen Black Inspection)				MI
Line Defect	Obvious vertical or horizontal line defect is not allowed.			
Mura	Not allowed if it can be observed through ND Filter 5 %			
Foreign Material in spot shape *Note-3	$D \leq 0.2\text{mm}$: Ignored $0.2\text{mm} < D \leq 0.3\text{mm}$: $N \leq 3$			
Foreign Material in line or spiral shape *Note-4	$W \leq 0.05\text{mm}$ or $L \leq 3\text{mm}$: Ignored $0.05\text{mm} < W \leq 0.1\text{mm}$ and $1.0\text{mm} < L \leq 2\text{mm}$: $N \leq 4$ $W > 0.1\text{mm}$ or $L > 5\text{mm}$: Not allowed			
Display Function Abnormal	No Malfunction can be allowed			

Note-1 : I/O Area Definition

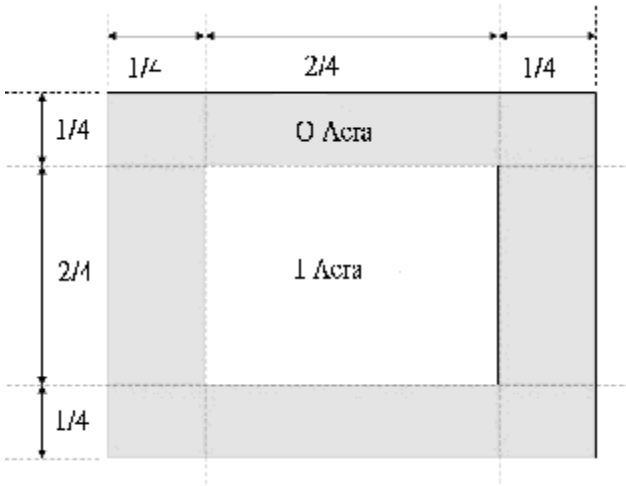

Note-2 : Polarizer Scratch

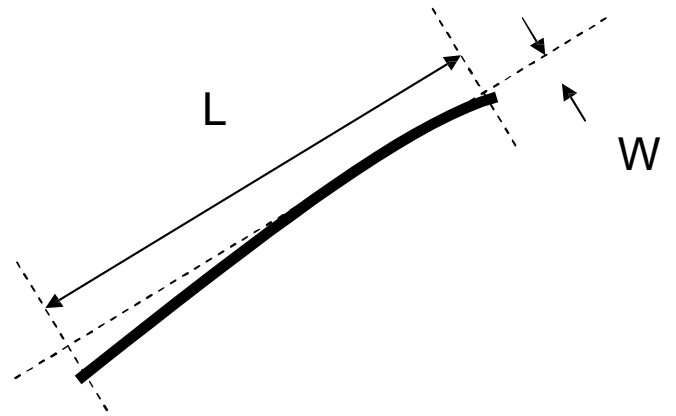

Note-3 : Spot Foreign Material
($W \geq L / 4$)

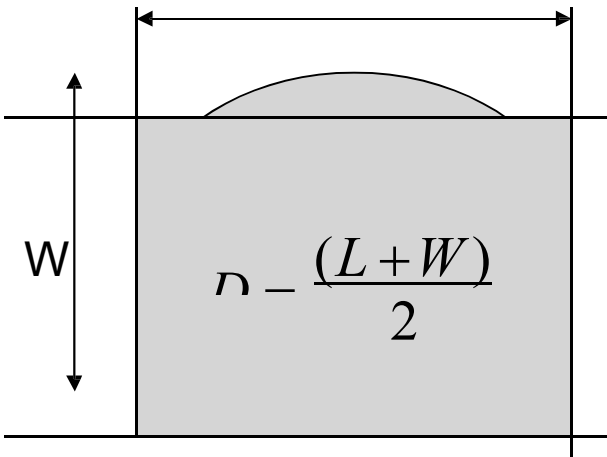

Note-4 : Line or Spiral Foreign Material
($W < L / 4$)

