

**DISPLAY Elektronik GmbH**

**DATA SHEET**

**LCD MODULE**

**DEM 240128D FGH-PW  
(D-TOUCH)**

*Product Specification*

*Version: 13.1.3*

**02.Sep/2009**

# GENERAL SPECIFICATION

MODULE NO. :

## DEM 240128D FGH-PW (D-TOUCH)

CUSTOMER P/N

VERSION NO.	CHANGE DESCRIPTION	DATE
0	ORIGINAL VERSION	14.04.2005
1	CHANGED SERIES	02.08.2005
2	CHANGED MODULE DRAWING AND PIN ASSIGNMENT	04.08.2005
3	CHANGED PIN ASSIGNMENT	11.08.2005
4	CHANGED MODEL AND PCB DRAWING	01.09.2005
5	CHANGED MODEL DRAWING	09.01.2006
6	MODIFY DESCRIPTION	20.02.2006
7	ADDED VERSION	06.07.2006
8	CHANGED MODEL DRAWING AND BACKLIGHT LUMINANCE	07.11.2006
9	CHANGED JUMPER DESCRIPTION	09.01.2007
10	ADDED VERSION	18.01.2007
11	ADDED VERSION	23.03.2007
12	MODIFY DESCRIPTION	14.07.2007
13	UPDATE LED RESISTORS	05.10.2007
13.1.1	CHANGE LCD-DRIVER	04.08.2008
13.1.3	IMPROVE LED-BACKLIGHT	02.09.2009

PREPARED BY: Huang Cailin

DATE: 2009/09/02

APPROVED BY: Wei Hongke

DATE: 2009/09/02

**CONTENTS**

**1. FUNCTIONS & FEATURES .....2**

**2. MODULE ARTWORK.....2**

**3. EXTERNAL DIMENSIONS .....3**

**4. BLOCK DIAGRAM.....4**

**5. PIN ASSIGNMENT .....5**

**6. POWER SUPPLY.....6**

**7. ABSOLUTE MAXIMUM RATINGS .....6**

**8. PCB DRAWING AND DESCRIPTION .....7**

**9. BACKLIGHT ELECTRICAL/OPTICAL SPECIFICATIONS.....9**

**10. TOUCH PANEL SPECIFICATIONS .....10**

**11. ELECTRICAL CHARACTERISTICS .....16**

**12. LCD MODULES HANDLING PRECAUTIONS.....17**

**13. OTHERS .....17**

# **DEM 240128D FGH-PW (D-TOUCH)      Product Specification**

## **1. FUNCTIONS & FEATURES**

<b>MODULE NAME</b>	<b>LCD Type</b>
DEM 240128D FGH-PW (D-TOUCH)	FSTN Transflective Positive Mode

- Glass Thickness : 1.1mm
- Viewing Direction : 6 O'clock
- Driving Scheme : 1/128Duty, 1/12 Bias
- Power Supply for logic : 5.0 Volt (typ.)
- Backlight Color : LED, Lightguide, White
- Display Content : 240 x 128 Dots
- $V_{LCD}$  : 20.0 Volt (typ.)
- Controller IC : T6963C (Toshiba)
- With touch panel : Anti-glare, Digital-Touch-Panel on Board

## **2. MODULE ARTWORK**

- Module Size : 144.00 x 104.00 x 14.10 mm
- Viewing Area : 114.00 x 64.00 mm (LCD or Touch panel)
- Active Area : 107.70 x 56.40 mm (Touch panel)
- Active Area : 107.95 x 57.55 mm (LCD)
- Dot Pitch : 0.45 x 0.45 mm (LCD)
- Dot Pitch : 6.75 x 9.45 mm (Touch panel)
- Dot Size : 0.40 x 0.40 mm (LCD)
- Dot Size : 6.45 x 9.15 mm (Touch panel)
- Dot Gap : 0.05 mm (LCD)
- Dot Gap : 0.30 mm (Touch panel)

## 3. EXTERNAL DIMENSIONS

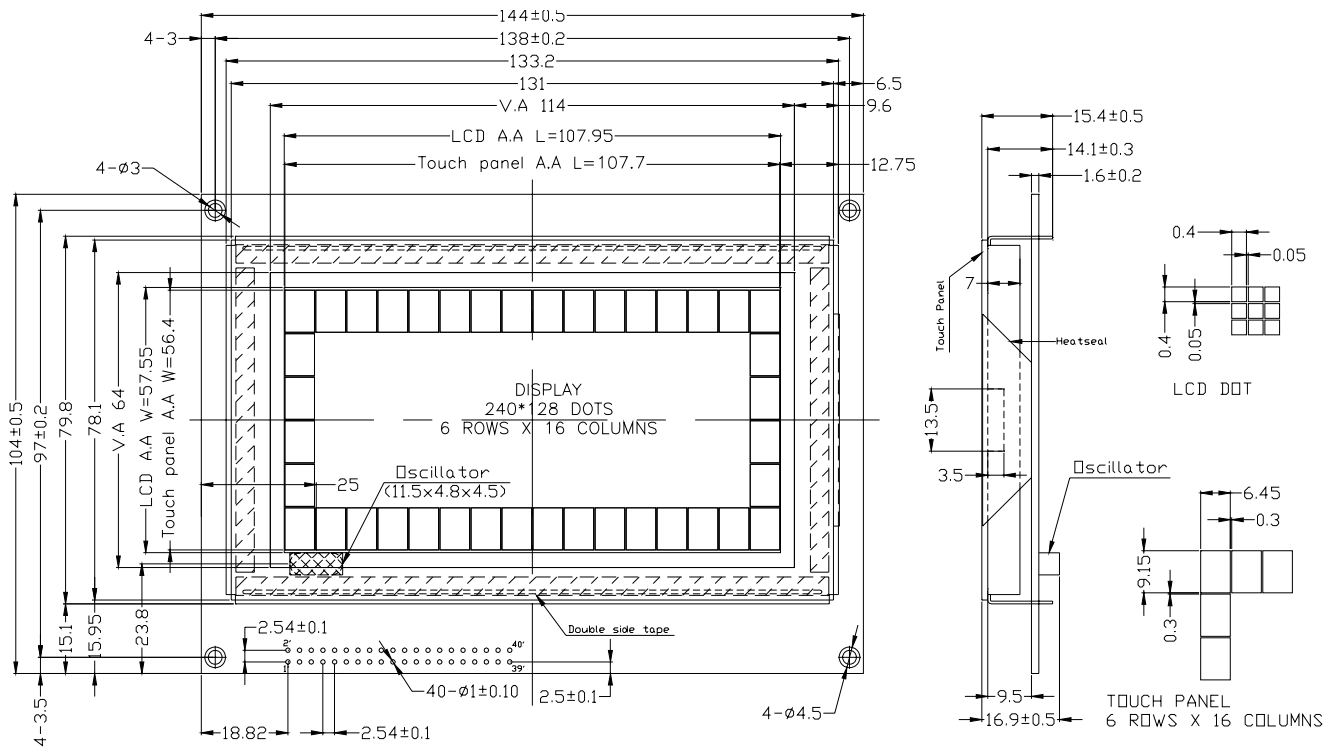

Remarks:  
 1, Unmarked tolerance is  $\pm 0.3$   
 2, All materials comply with RoHs.

**4. BLOCK DIAGRAM**

**4.1 Block Diagram of LCD Module**

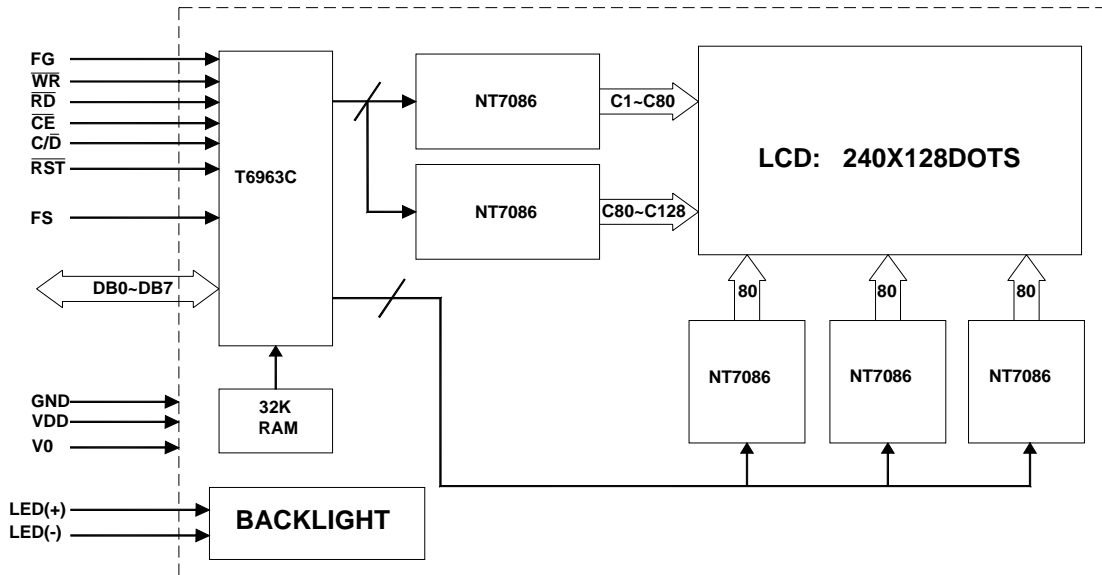

**4.2 Digital Touch Screen Auto-Scanning Block Diagram**

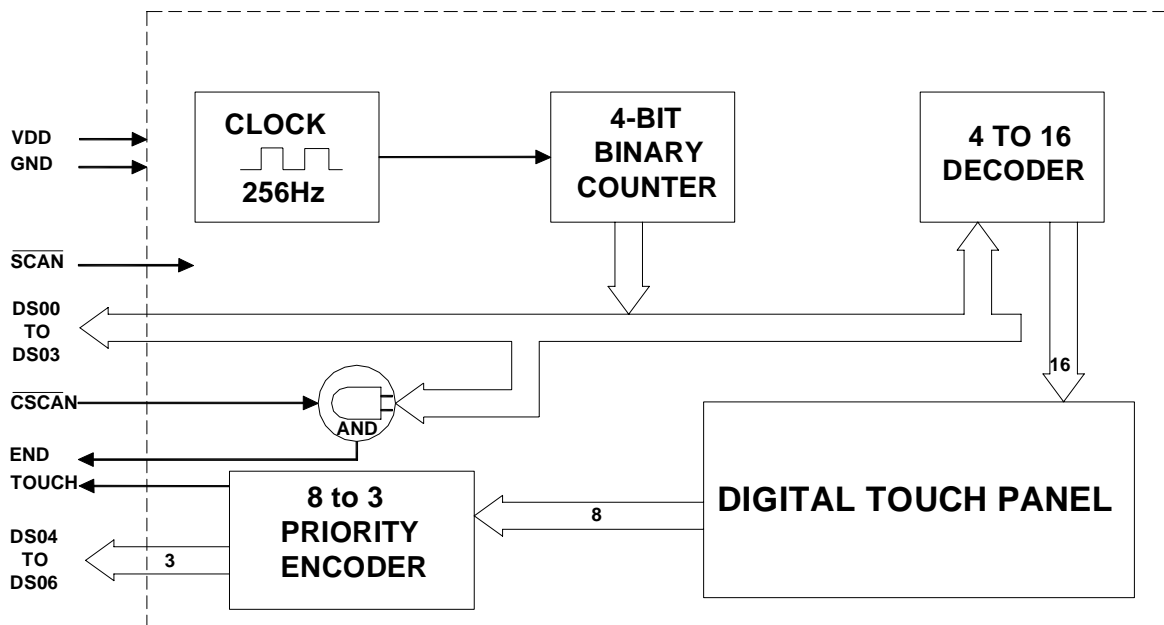

## 5. PIN ASSIGNMENT

No.	Symbol	Function
1	FG	Frame ground
2	/CSCAN	Active LOW: Force column scan counter to run continuously in order to obtain a complete cycle
3	VSS	Ground(0V)
4,6,8,10	DS00~DS03	4 bits to indicate the column being scanned: range0 to 15 corresponding to COL1 to COL16, with DS00 as LSB. Output is latched at the most recently touched position. When read while "TOUCH" is positive, the touched column is identified.*
5	VDD	Power supply for logic(+5V)
7	V0	Power supply for LCD drive(-15V)
9	/WR	Write Command or data to module when "L"
11	/RD	Read Command or data from module when "L"
12,14,16	DS04~DS06	3bits to indicate the row being scanned: range 0 to 7 corresponding to ROW1 to ROW8, with DS4 as LSB & DS6 as MSB. Output is latched at the most recently touched position. When read while "TOUCH" is positive, the touched column is identified.*
13	/CE	Enable LCD controller when "L"
15	C//D	Command/data select. "H" for command read/write. "L" for data read/write
17	/RST	LCD Controller reset. Controller initialize and DB00-DB07 are set to be high impedance when/RST is "L"
18	//SCAN	Active LOW: Standby to scan. Scanning will begin when a touch is identified at any of the sensing position, and will continue until touch is removed.
19,21,23,25, 27,29,31,33,	DB0~DB7	LCD data input/output. DB0(pin10) is LSB and DB7(pin17) is MSB.
20	END	A 4ms positive pulse generated at the end of a complete scan cycle (Max cycle time: 64ms)
22	TOUCH	A 2ms negative pulse when scanning reaches an identified touch position. It can be used as an interrupt.
24,26,28,30,3 2,34,36,38,40	NC.	No Connection
35	FS	Font select. "H" for 6x8 font & "L" for 8x8 font
37	LED+(A)	Please refer to item 8.1 PCB drawing and description
39	LED-(K)	

\* If DS00 to DS06 is read at the "END, then the last touched position will be identified.

**6. POWER SUPPLY**

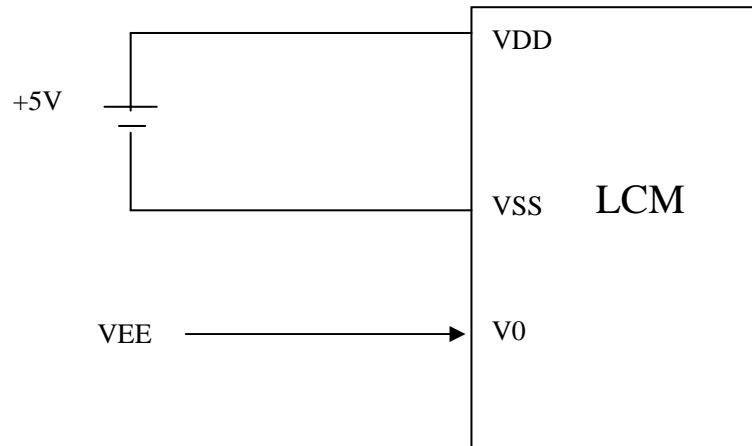

**7. ABSOLUTE MAXIMUM RATINGS (V<sub>SS</sub>=0V, T<sub>a</sub>=25°C)**

Parameter	Symbol	Rating	Unit
Supply Voltage (Logic)	V <sub>DD</sub>	-0.3 to 7.0	V
Input voltage	V <sub>IN</sub>	-0.3 to V <sub>DD</sub> +0.3	V
Operating Temperature	T <sub>opr</sub>	-20 to +70	°C
Storage Temperature	T <sub>stg</sub>	-25 to +75	°C



**8. PCB DRAWING AND DESCRIPTION**

**8.1. PCB DRAWING**

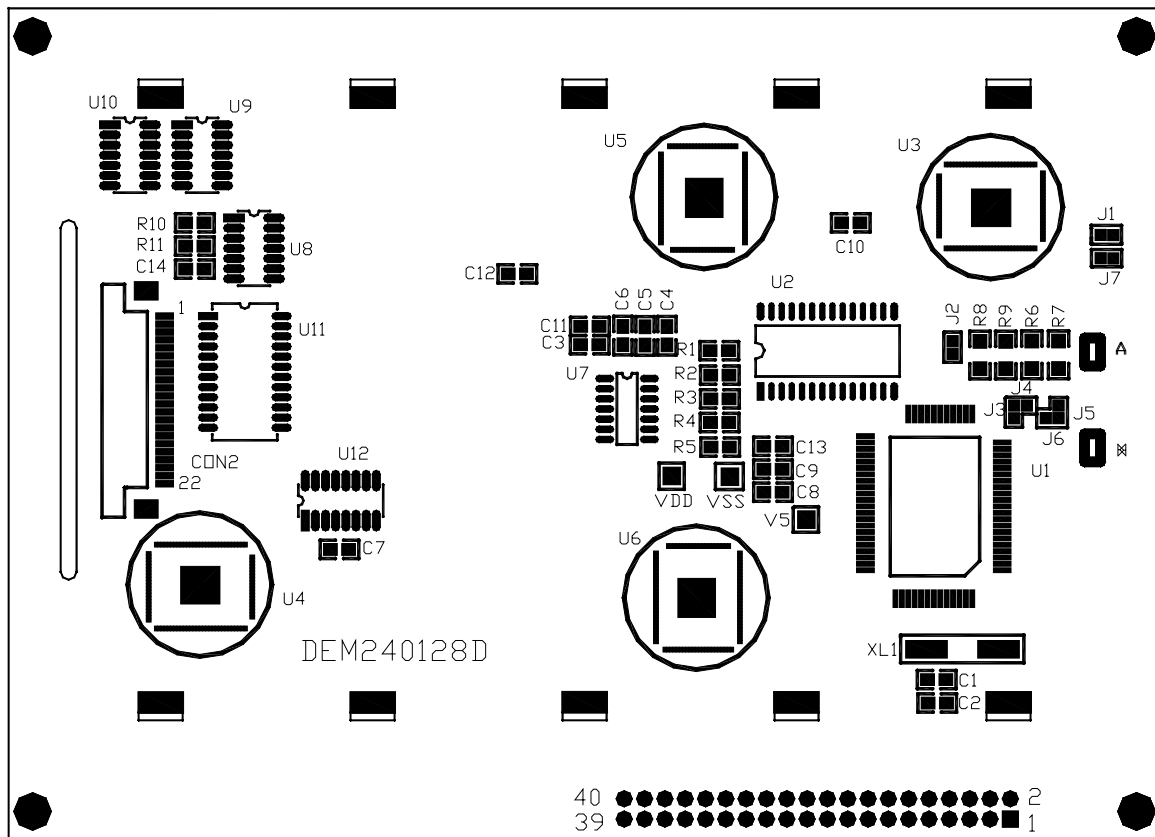

**8.2 DESCRIPTION:**

**8-2-1. The polarity of the pin 37 and the pin 39:**

J3,J5	J6, J4	LED Polarity	
		37 Pin	39 Pin
Each open	Each closed	Anode	Cathode
Each closed	Each open	Cathode	Anode

Note: In application module, J3=J5=open, J4=J6=0 Ohm.

**8-2-2. The J1 is metal-bezel GND to module GND and J7 is mounting holes GND to module GND.**

Note: In application module, J1= J7=0 Ohm,

**8-2-3. The LED resistor on board are used when J2 is open**

Note: In application module, J2=open

**8-2-4. The R6 and the R7, R8, R9 are the LED resistor.**

Note: In application module, R6= R7=open, R8=R9=82ohm

**8.3 Example application**

8-3-1. The LED resistors on board can be disabled when J2 is closed. Then customer needs to use external resistors

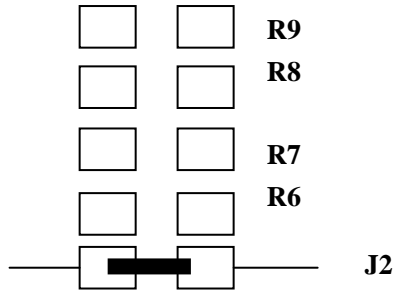

8-3-2. The 37 pin is the anode and the 39 pin is the cathode as following.



8-3-3. The 37 pin is the cathode and the 39 pin is the anode as following.



8-3-4. The metal-bezel is on ground as following



8-3-5. The holes is on ground as following



# DEM 240128D FGH-PW (D-TOUCH) Product Specification

## 9. BACKLIGHT ELECTRICAL/OPTICAL SPECIFICATIONS

### ELECTRICAL–OPTICAL CHARACTERISTICS

Item	Symbol	min.	typ.	max.	Unit	Condition
Forward Voltage	Vf	2.9	3.2	3.4	V	If= 45 mA
Reverse Current	Ir		30		$\mu$ A	Vr= 0.8 V
Luminance	Lv	165	220		cd/m <sup>2</sup>	If= 45 mA

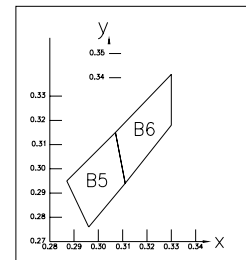
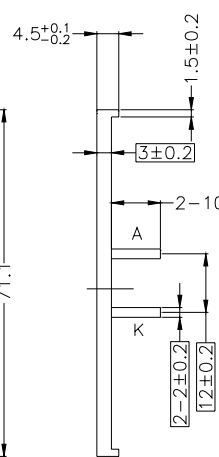
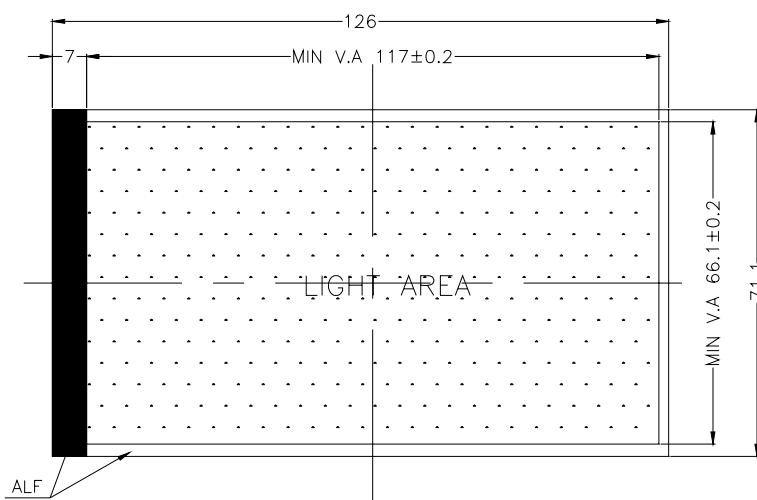

#### CHROMATICS COORDINATES

	x	0.296	0.287	0.330	0.330
y		0.276	0.295	0.339	0.318

TOLERANCE IS ±0.01



- Remarks:
1. Unmarked tolerance is ±0.3
  2. Color: white
  3. All materials comply with RoHs

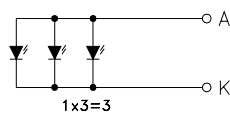

## **10. TOUCH PANEL SPECIFICATIONS**

### **10.1 Electrical Characteristics of Digital Touch Panel**

- 1). Max rating: DC. 10V, 1mA
- 2). Insulating resistance: More than 100meg-ohms at DC. 25 volts.
- 3). Contact resistance: 20K Ohms or less.
- 4). Contact bounce: Less than 15 msec (\*Input by finger).
- 5). Withstand voltage: Withstanding an applied voltage of AC. 25 volts (50Hz, 0.5mA) each terminal for one minutes.  
Shall not be any mechanical or electrical failures.

### **10.2 Mechanical Characteristics of Digital Touch Panel**

- 1). Activation force: 10~35 gf (Diagonal cross point except dot spacer).
- 2). Using by the silicon finger, hardness test with=60<sup>0</sup> of R=10mm
- 3). Surface hardness: 2H (based on pencil hardness test with JIS K5400).
- 4). Total light transparency: 70% or more.
- 5). Transmission Haze: 6.0% (typical value).

**10.3 Flow Chart of Touch Panel Programming**

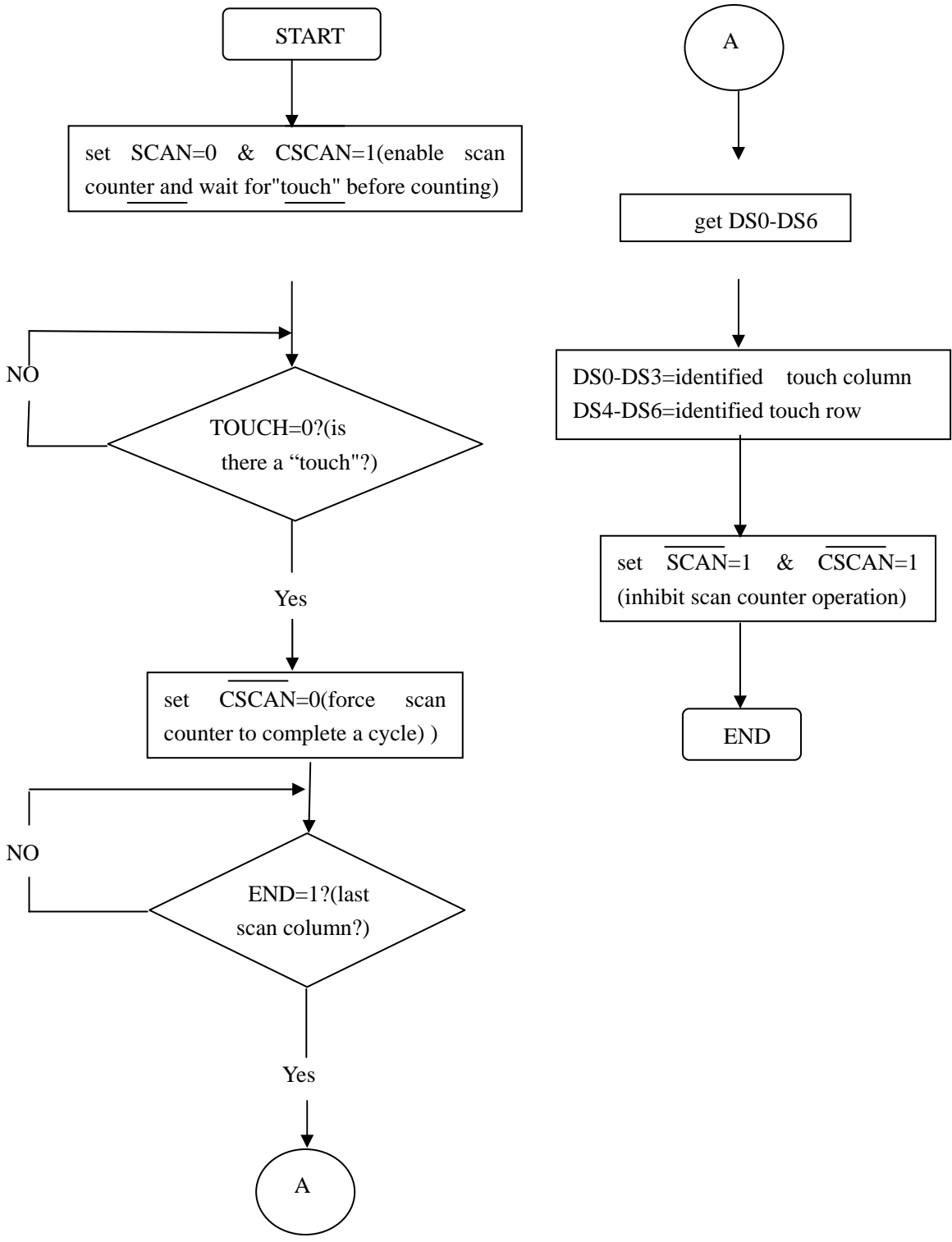

## 10.4 Timing Diagrams for Digital Touch Panel Auto-Scanning Mode

CASE1: Single key is pressed (column11-row4 is pressed)

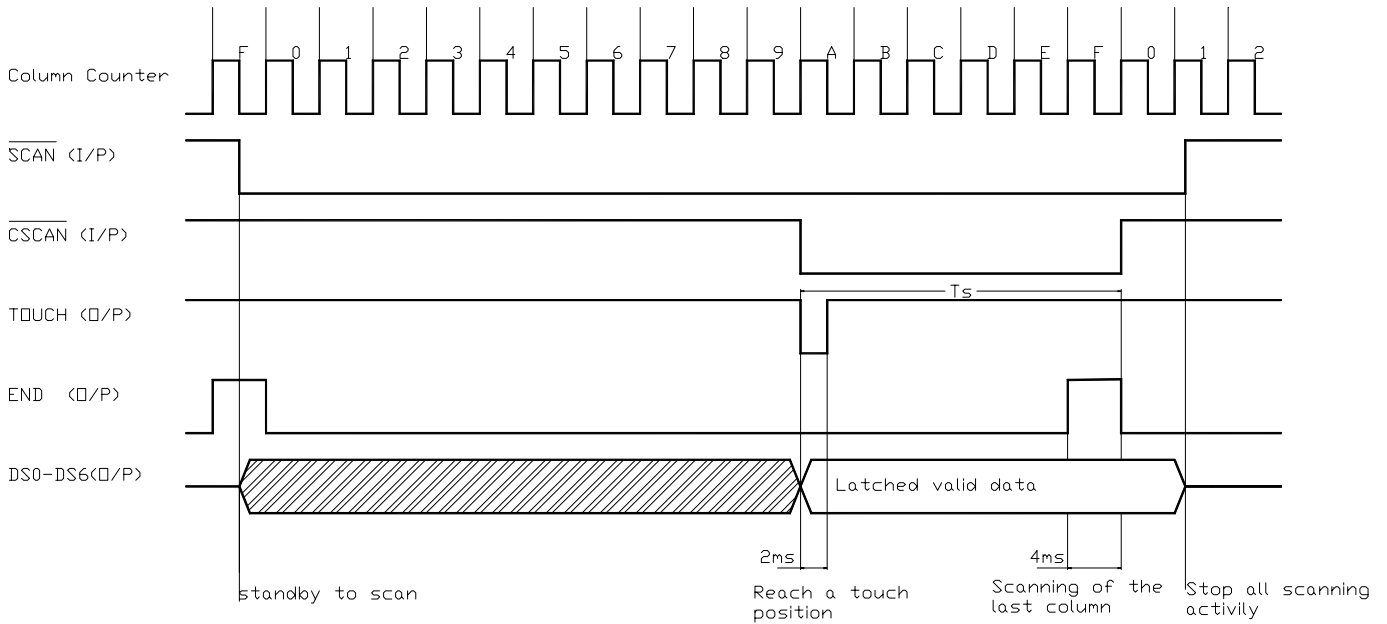

- Remark: 1. Max.  $T_s = 64\text{ms}$  (dependent on which key is pressed)  
 2. No. of TOUCH pulse = No. of key pressed at one time

CASE2: Double keys are pressed (column5-rows4 and column11-rows4 are pressed)

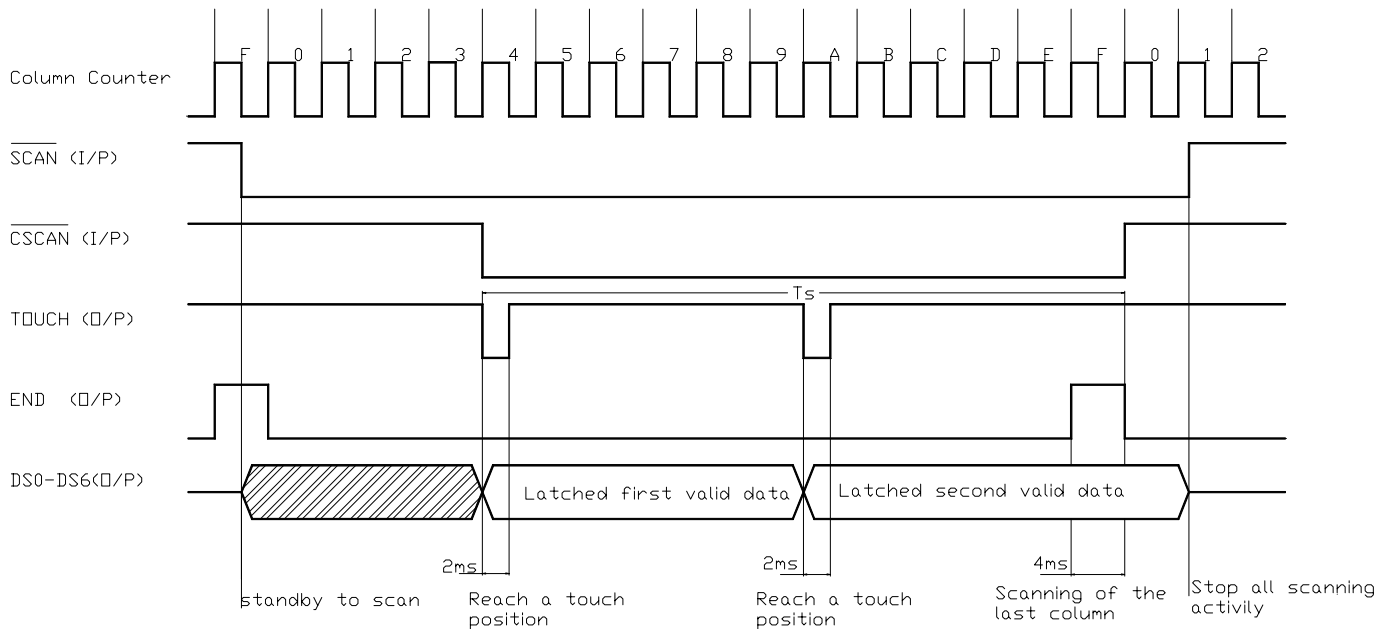

- Remark: 1. Max.  $T_s = 64\text{ms}$  (dependent on which key is pressed).  
 2. No. of TOUCH pulse = No. of key pressed at one time.

# DEM 240128D FGH-PW (D-TOUCH) Product Specification

CASE3:last column key pressed (column 5-rows4 are pressed)

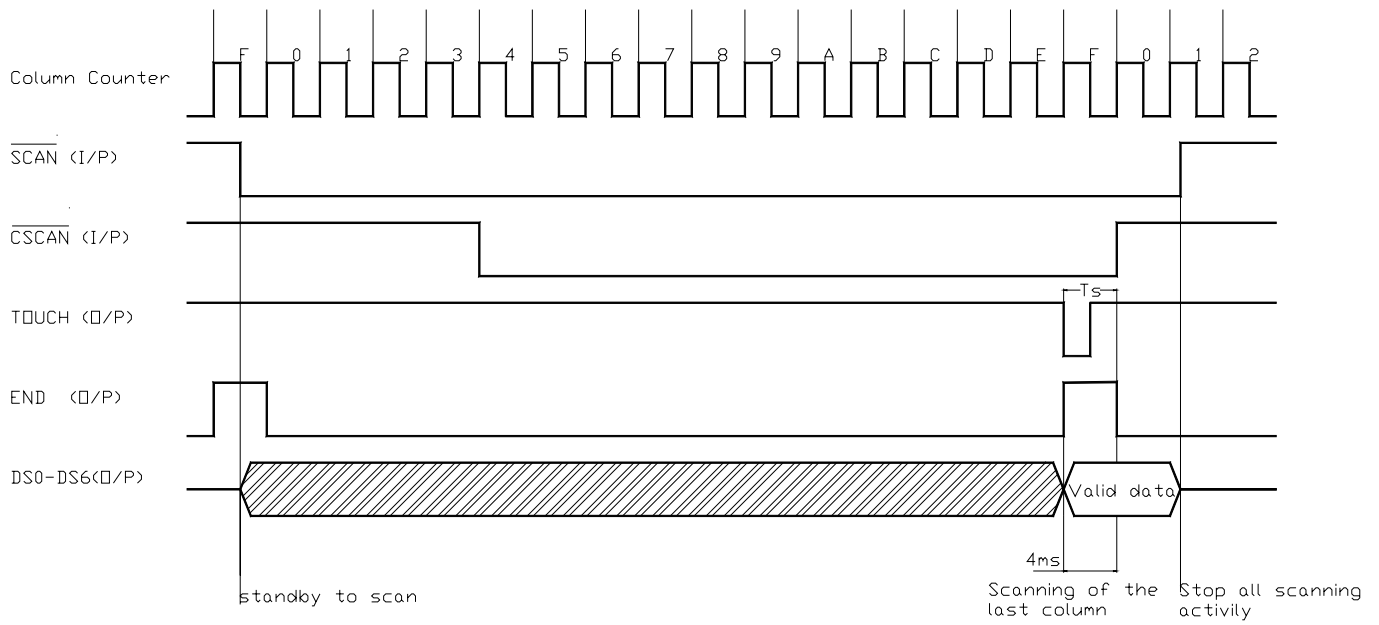

- Remark: 1. Max.  $T_s = 64\text{ms}$  (dependent on which key is pressed).  
 2. No. of TOUCH pulse = No. of key pressed at one time.

# DEM 240128D FGH-PW (D-TOUCH) Product Specification

## 10.5 Multiple Touch Situation

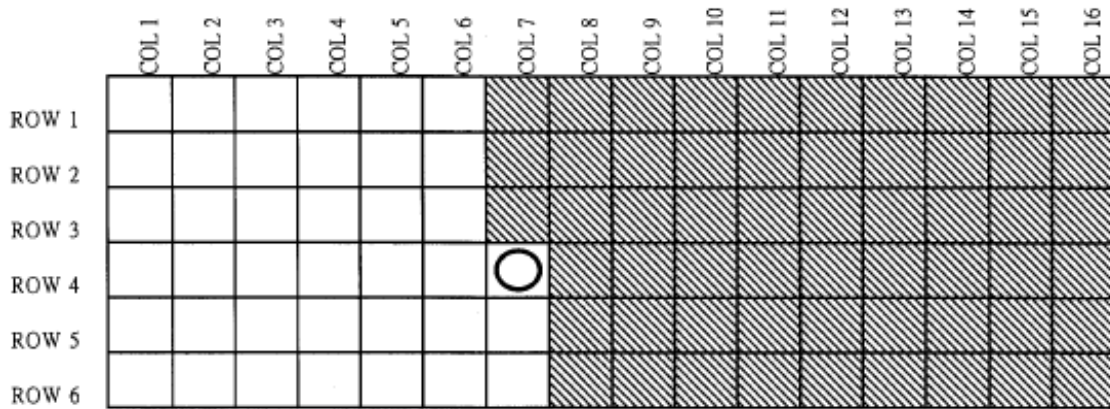

Column on the Right have higher priority than column on the Left.

Row on the Upper have higher priority than row on the Lower.

Column have higher priority than Row.

The above demonstration is when you press column 7 - row 4 with another key at the same times, the keys insides gray area have higher priority than column 7 - row 4. However, when you press column 7 - row 4 with the key insides white area, column 7 - row 4 have higher priority.

For example, if you press column 7 - row 4 with column 11 - row 2, the hardware will output column 11 - row 2. Another example, if you press column 7 - row 4 with column 3 - row 1, the hardware will output column 7 - row 4.

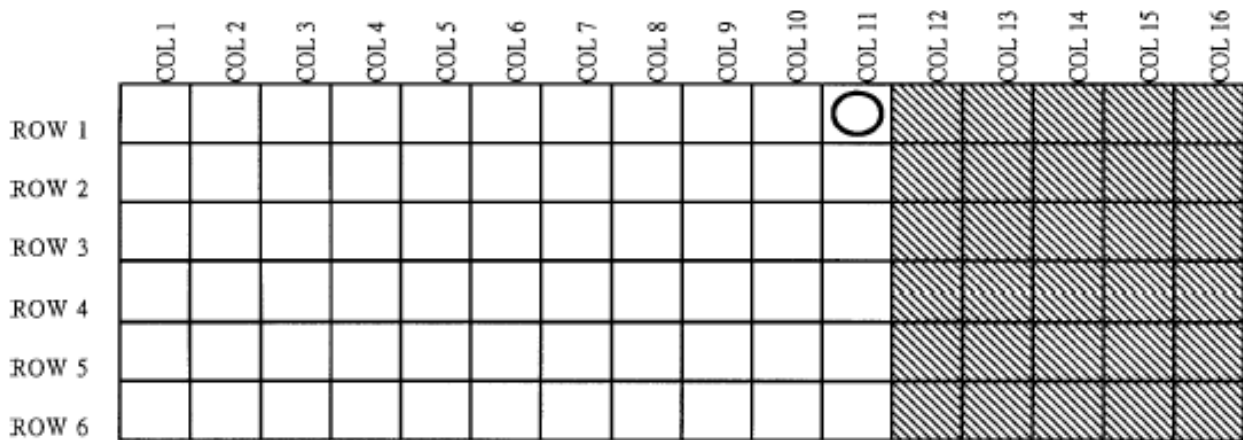

This is another example. When user press on column 11 - row 1 with another key at the same time.

Gray area means have higher priority than column 11 - row 1.



# DEM 240128D FGH-PW (D-TOUCH) Product Specification

## 10.6 Touch Panel Drawing

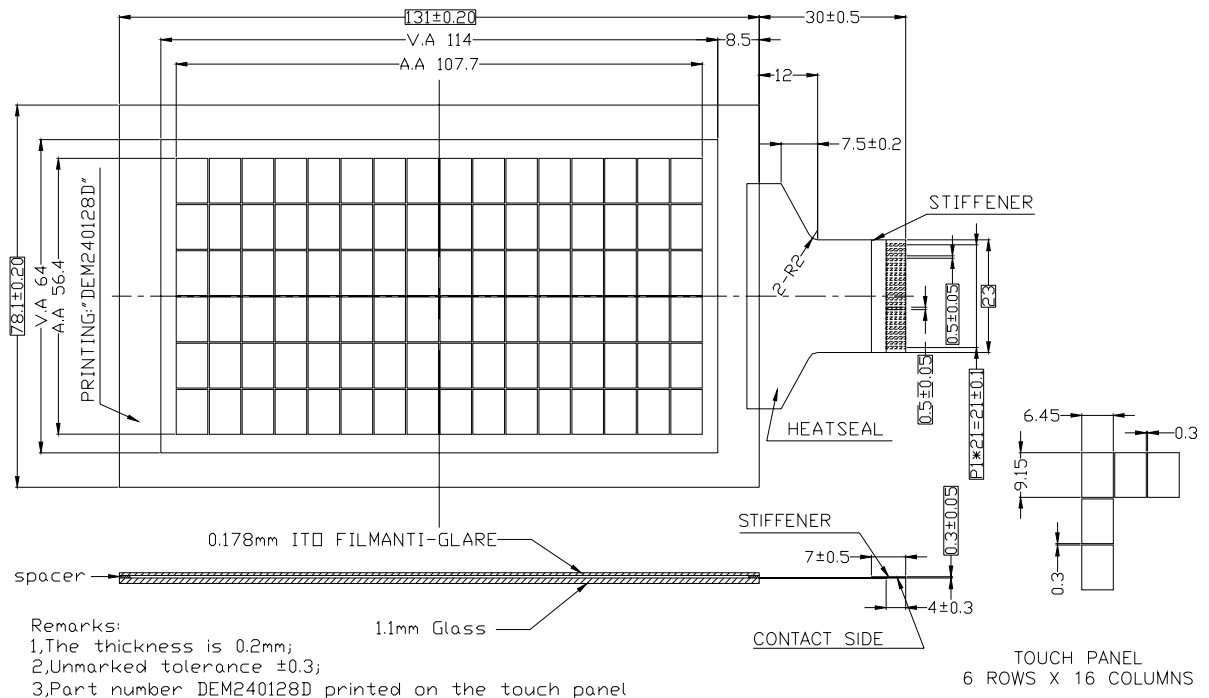

## 11. ELECTRICAL Characteristics

### 11.1 DC Characteristics

Ta=25°C, V<sub>SS</sub>=0V

Parameter	Symbol	Conditions	Min.	Typ.	Max.	Units
Supply Voltage (Logic)	V <sub>DD</sub> -V <sub>SS</sub>	-	4.5	5.0	5.5	V
Current Consumption(Operating)	I <sub>DD(1)</sub>	V <sub>DD</sub> =5.0V f <sub>OSC</sub> = 3.0 MHz	-	3.3	6.0	mA
Current Consumption(Halt)	I <sub>DD(2)</sub>	V <sub>DD</sub> =5.0V			3	uA

### 11.2 AC Characteristics

Parameter	Symbol	Min.	Max.	Units
C/D Setup Time	t <sub>CDS</sub>	100	-	ns
C/D Hold Time	t <sub>CDH</sub>	10	-	ns
CE, RD, WR Pulse Width	t <sub>CE</sub> , t <sub>RD</sub> , t <sub>WR</sub>	80	-	ns
Data Setup Time	t <sub>DS</sub>	80	-	ns
Data Hold Time	t <sub>DH</sub>	40	-	ns
Access Time	t <sub>ACC</sub>	-	150	ns
Output Hold Time	t <sub>OH</sub>	10	50	ns

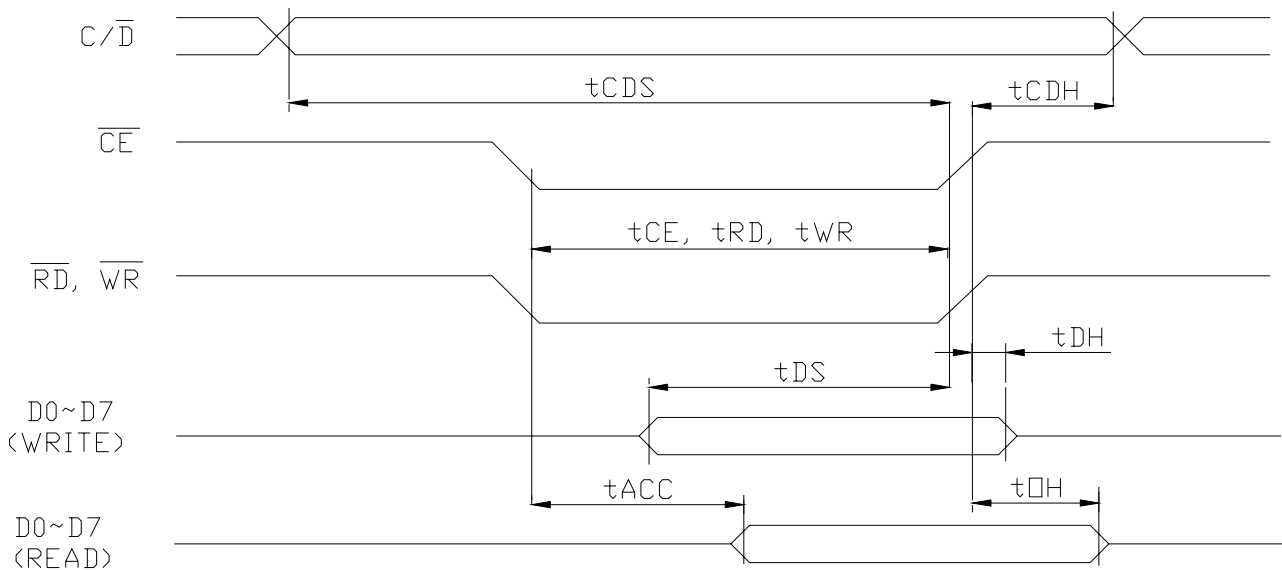

## **12. LCD MODULES HANDLING PRECAUTIONS**

- Please remove the protection foil of polarizer before using.
- The display panel is made of glass. Do not subject it to a mechanical shock by dropping it from a high place, etc.
- If the display panel is damaged and the liquid crystal substance inside it leaks out, do not get any in your mouth. If the substance come into contact with your skin or clothes promptly wash it off using soap and water.
- Do not apply excessive force to the display surface or the adjoining areas since this may cause the color tone to vary.
- The polarizer covering the display surface of the LCD module is soft and easily scratched. Handle this polarize carefully.
- To prevent destruction of the elements by static electricity, be careful to maintain an optimum work environment.
  - Be sure to ground the body when handling the LCD module.
  - Tools required for assembly, such as soldering irons, must be properly grounded.
  - To reduce the amount of static electricity generated, do not conduct assembly and other work under dry conditions.
  - The LCD module is coated with a film to protect the display surface. Exercise care when peeling off this protective film since static electricity may be generated.
- Storage precautions  
When storing the LCD modules, avoid exposure to direct sunlight or to the light of fluorescent lamps. Keep the modules in bags designed to prevent static electricity charging under low temperature / normal humidity conditions (avoid high temperature / high humidity and low temperatures below 0°C). Whenever possible, the LCD modules should be stored in the same conditions in which they were shipped from our company.

## **13. OTHERS**

- Liquid crystals solidify at low temperature (below the storage temperature range) leading to defective orientation of liquid crystal or the generation of air bubbles (black or white). Air bubbles may also be generated if the module is subjected to a strong shock at a low temperature.
- If the LCD modules have been operating for a long time showing the same display patterns may remain on the screen as ghost images and a slight contrast irregularity may also appear. Abnormal operating status can be resumed to be normal condition by suspending use for some time. It should be noted that this phenomena does not adversely affect performance reliability.
- To minimize the performance degradation of the LCD modules resulting from caused by static electricity, etc. exercise care to avoid holding the following sections when handling the modules:
  - Exposed area of the printed circuit board
  - Terminal electrode sections