

Display Elektronik GmbH

DATA SHEET

TFT MODULE

DEM 1920360B VM-PW-N

21,2"

Product Specification

Ver.: 0

21.11.2019

Revision History

Revision	Date	Originator	Detail	Remarks
0	21.11.2019	ZDT	Initial Release	

Table of Contents

No.	Item	Page
1.	General Description	4
2.	Module Parameter.....	4
3.	Absolute Maximum Ratings	4
4.	DC Characteristics	5
5.	Backlight Characteristic.....	5
	5.1. Backlight Characteristic	5
	5.2. Backlight Characteristic	5
6.	Optical Characteristics	6
	6.1. Definition of Response Time.....	6
	6.2. Definition of Contrast Ratio.....	7
	6.3. Definition of Viewing Angles	7
	6.4. Definition of Color Appearance	8
	6.5. Definition of Surface Luminance, Uniformity and Transmittance.....	8
7.	Block Diagram and Power Supply	9
8.	Interface Pins Definition	10
9.	Signal Timing Specification	11
	9.1. Timing Parameters (DE only mode)	11
	9.2. Signal Timing Waveform	12
10.	Power Sequence.....	13
11.	Quality Assurance	14
	11.1. Purpose	14
	11.2. Standard for Quality Test.....	14
	11.3. Nonconforming Analysis & Disposition	14
	11.4. Agreement Items.....	14
	11.5. Standard of the Product Visual Inspection.....	15
	11.6. Inspection Specification for the TFT module.....	15
	11.7. Classification of Defects.....	19
	11.8. Identification/marketing criteria	19
	11.9. Packing	19
12.	Reliability Specification	20
13.	Precautions and Warranty.....	21
	13.1. Safety.....	21
	13.2. Handling.....	21
	13.3. Storage.....	21
	13.4. Metal Pin (Apply to Products with Metal Pins).....	21
	13.5. Operation	22
	13.6. Static Electricity.....	23
	13.7. Limited Warranty.....	23
14.	Packaging	Fehler! Textmarke nicht definiert.
15.	Outline Drawing.....	24

1. General Description

The specification is a transmissive type color active matrix liquid crystal display (LCD) which uses amorphous thin film transistor (TFT) as switching devices. This product is composed of a TFT-LCD panel, driver ICs, and a backlight unit.

2. Module Parameter

Features	Details	Unit
Display Size (Diagonal)	21.2"	
Display Mode	Transmissive / Normally Black	
Resolution	1920 x RGB x 360	Pixels
View Direction	FULL VIEW	Best Image
Module Outline	553.72 x124.55 x 6.52 (Note1)	mm
Active Area	529.42 x 99.27	mm
Pixel Pitch	0.27573 x 0.27573	mm
Pixel Arrangement	RGB Vertical Stripe	
Display Colors	16.7 Million	
Interface	LVDS Interface	
With or Without Touch Panel	Without	
Operating Temperature	0~50	°C
Storage Temperature	-20~60	°C
Weight	TBD	g

Note 1: Exclusive hooks, posts, FFC/FPC tail etc.

3. Absolute Maximum Ratings

GND=0V, Ta=25°C

Item	Symbol	Min.	Max.	Unit
Supply Voltage	VDD	-0.3	13.2	V
Storage Temperature	T _{STG}	-20	+60	°C
Operating Temperature	T _{OP}	0	+50	°C

Note 1: If Ta below 50°C, the maximal humidity is 90%RH, if Ta over 50°C, absolute humidity should be less than 60%RH.

Note 2: The response time will be extremely slow when the operating temperature is around -10°C, and the back ground will become darker at high temperature operating.

4. DC Characteristics

Item		Symbol	Min.	Typ.	Max.	Unit
Supply Voltage		VDD	10.8	12	13.2	V
LVDS Interface	Differential Input High Threshold Voltage	VLVTH	100	-	300	mV
	Differential Input Low Threshold Voltage	VLVTL	-300	-	-100	mV
	Common Input Voltage	VLVC	1.0	1.2	1.4	V
CMOS Interface	Input High Threshold Voltage	VIH	2.7	-	3.3	V
	Input Low Threshold Voltage	VIL	0	-	0.6	V

5. Backlight Characteristic

5.1. Backlight Characteristic

Item	Symbol	Condition	Min.	Typ.	Max.	Unit
Backlight Voltage	V _{LED}	Ta=25 °C	-	23	-	V
Backlight Current	I _{LED}	Ta=25 °C	-	400	-	mA
Power Dissipation	P _D	-	-	9200	-	mW
Uniformity	Avg	-	-	80	-	%
LED Lifetime (25°C)	-	-	-	15000	-	Hrs
Drive Method	Constant Current					
LED Configuration	80 White LEDs (8 LEDs in one string and 10 groups in parallel)					

Note1: LED life time defined as follows: The final brightness is at 50% of original brightness.
 The environmental conducted under ambient air flow, at Ta=25± 2 °C,60%RH± 5%, If=400mA.

5.2. Backlight Characteristic

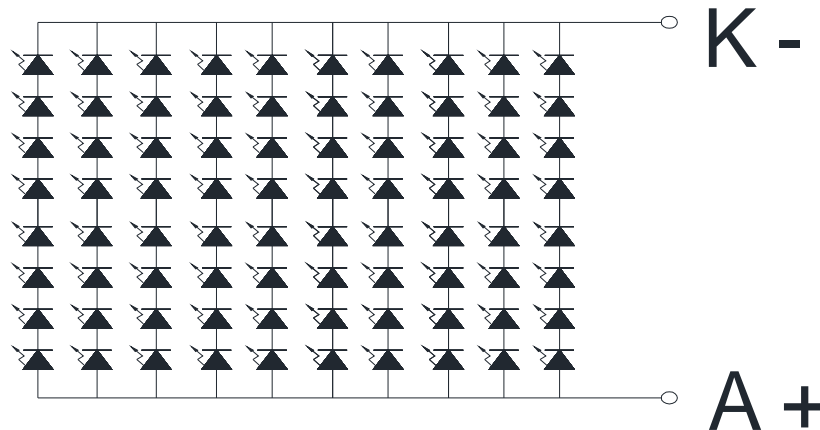

6. Optical Characteristics

Ta=25°C, VDD=12V

	Item	Symbol	Condition	Specification			Unit	
				Min.	Typ.	Max.		
Backlight On (Transmissive Mode)	Luminance On TFT(I _f =500mA)	Lv		320	400	-	cd/m ²	
	Contrast Ratio(See 6.3)	CR		800	1200	-		
	Response Time (See 6.2)	TR+TF		-	8	10	ms	
	Chromaticity Transmissive (See 6.5)	Red	X _R	Center CR≥10	-	TBD	-	
			Y _R		-	TBD	-	
		Green	X _G		-	TBD	-	
			Y _G		-	TBD	-	
		Blue	X _B		-	TBD	-	
			Y _B		-	TBD	-	
	White	X _W	-	TBD	-			
Y _W		-	TBD	-				
Viewing Angle (See 6.4)	Horizontal	θ _{X+}	Center CR≥10	-	89	-	Deg.	
		θ _{X-}		-	89	-		
	Vertical	φ _{Y+}		-	89	-		
		φ _{Y-}		-	89	-		
NTSC ratio (Color gamut)				-	72	-	%	

6.1. Definition of Response Time

6.1.1. Normally Black Type (Negative)

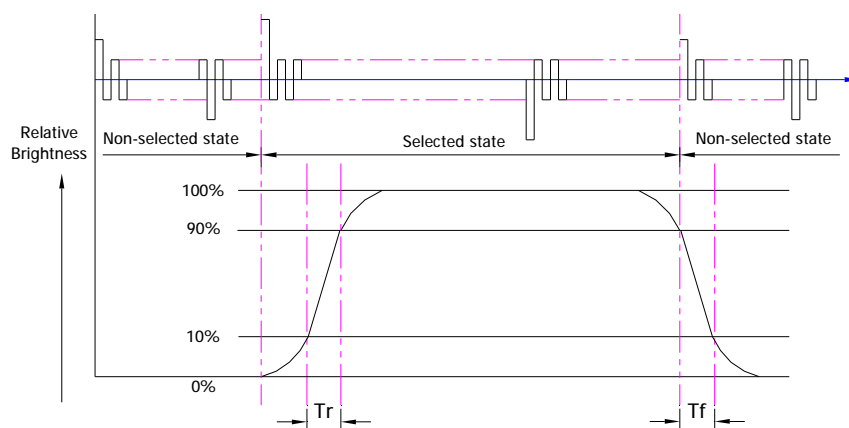

Tr is the time it takes to change from non-selected stage with relative luminance 10% to selected state with relative luminance 90%;

Tf is the time it takes to change from selected state with relative luminance 90% to non-selected state with relative luminance 10%.

Note: Measuring machine: LCD-5100

6.1.2. Normally White Type (Positive)

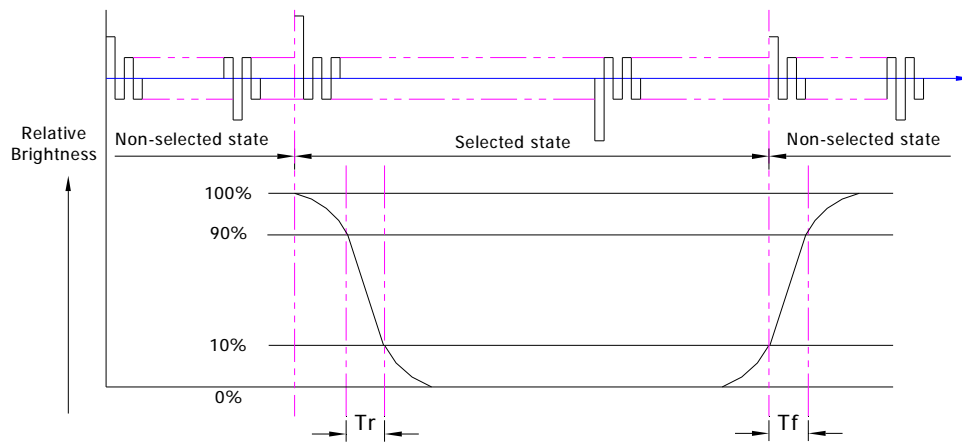

Tr is the time it takes to change from non-selected stage with relative luminance 90% to selected state with relative luminance 10%;

Tf is the time it takes to change from selected state with relative luminance 10% to non-selected state with relative luminance 90%;

Note: Measuring machine: LCD-5100 or EQUI

6.2. Definition of Contrast Ratio

Contrast is measured perpendicular to display surface in reflective and transmissive mode. The measurement condition is:

Measuring Equipment	Eldim or Equivalent
Measuring Point Diameter	3mm//1mm
Measuring Point Location	Active Area centre point
Test Pattern	A: All Pixels white
	B: All Pixel black
Contrast Setting	Maximum

Definitions: CR (Contrast) = Luminance of White Pixel / Luminance of Black Pixel

6.3. Definition of Viewing Angles

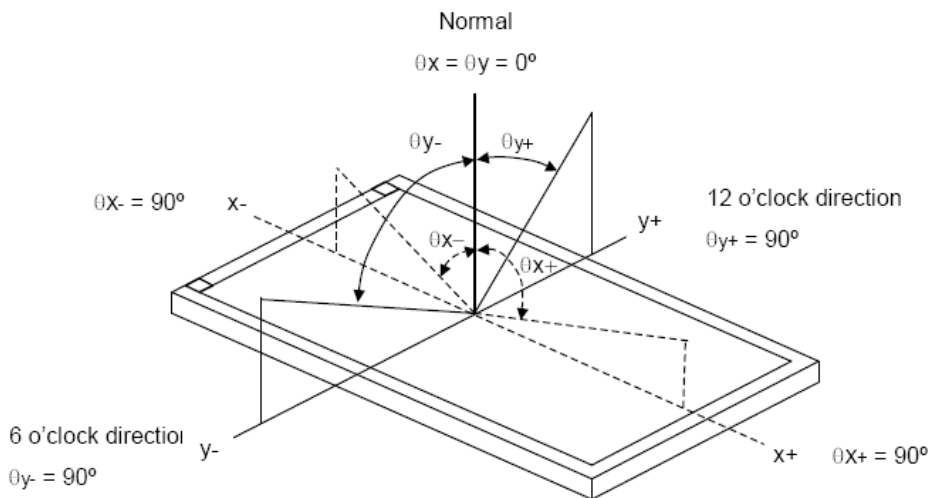

Measuring machine: LCD-5100 or EQUI

6.4. Definition of Color Appearance

R,G,B and W are defined by (x, y) on the IE chromaticity diagram

NTSC=area of RGB triangle/area of NTSC triangleX100%

Measuring picture: Red, Green, Blue and White (Measuring machine: BM-7)

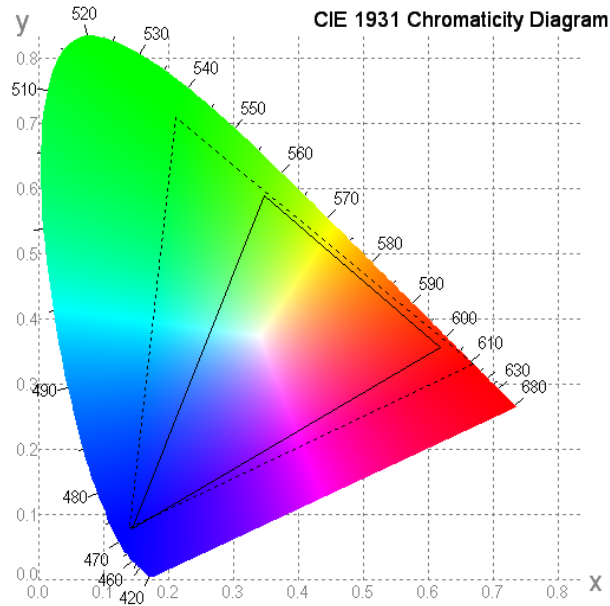

6.5. Definition of Surface Luminance, Uniformity and Transmittance

Using the transmissive mode measurement approach, measure the white screen luminance of the display panel and backlight.

6.5.1. Surface Luminance: $L_v = \text{average} (L_{P1}:L_{P9})$

6.5.2. Uniformity = $\text{Minimal} (L_{P1}:L_{P9}) / \text{Maximal} (L_{P1}:L_{P9}) * 100\%$

6.5.3. Transmittance = $L_v \text{ on LCD} / L_v \text{ on Backlight} * 100\%$

Note: Measuring machine: BM-7

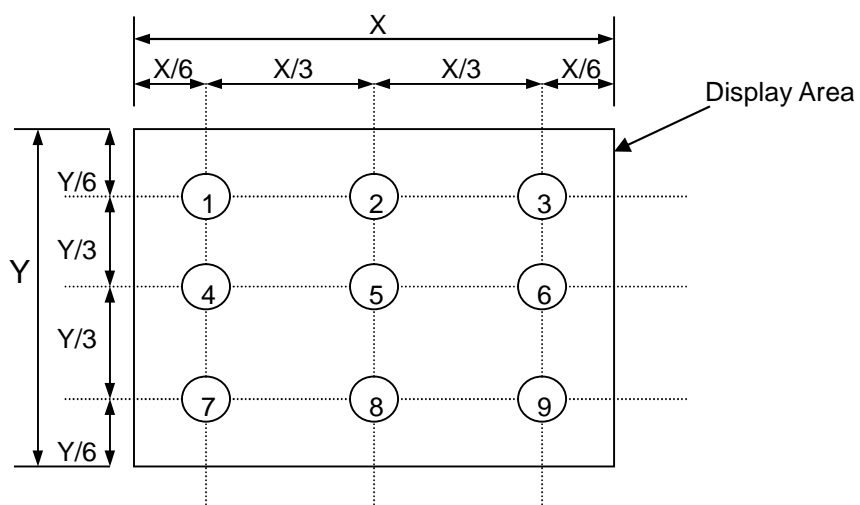

7. Block Diagram and Power Supply

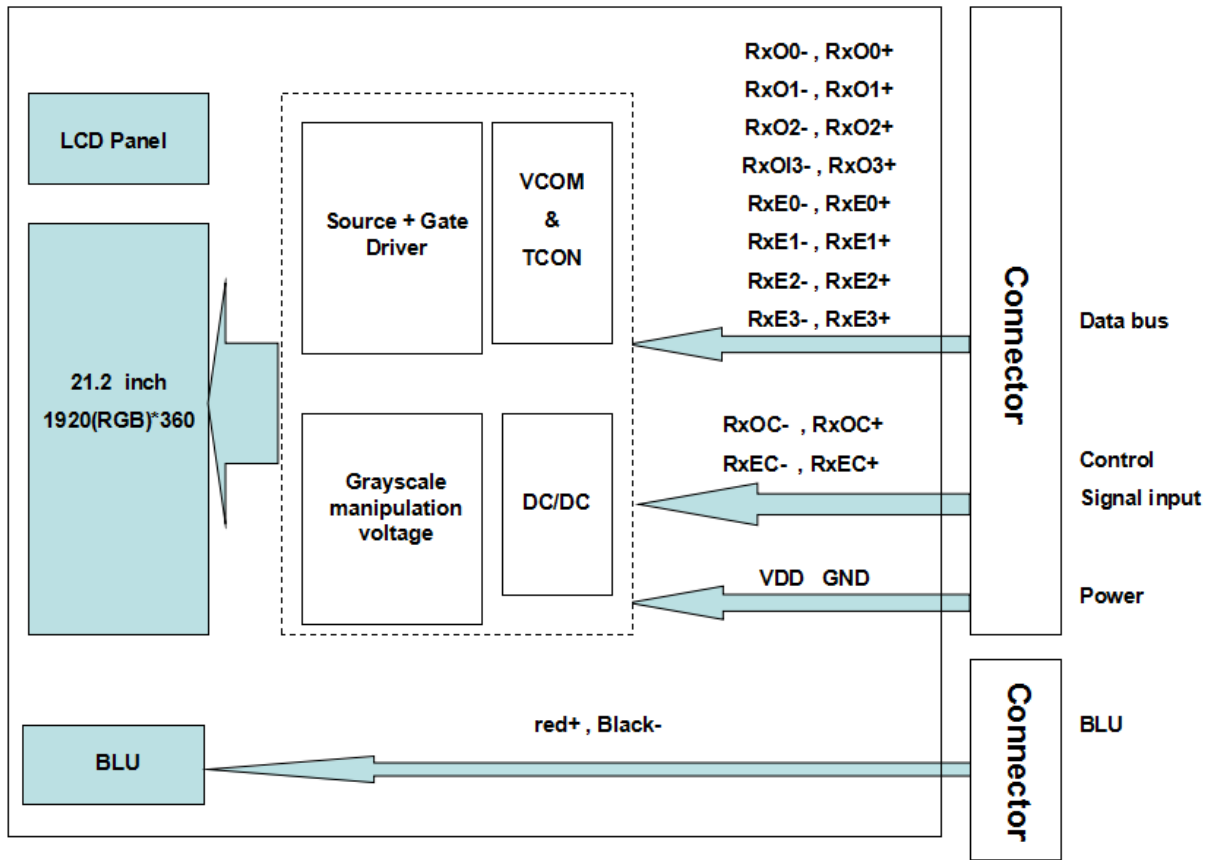

8. Interface Pins Definition

Connector : IS100-L300-C23(UJU)

No.	Symbol	Function	Remark
1	RXO0-	Negative Transmission data of Pixel 0 (ODD)	
2	RXO0+	Positive Transmission data of Pixel 0 (ODD)	
3	RXO1-	Negative Transmission data of Pixel 1 (ODD)	
4	RXO1+	Positive Transmission data of Pixel 1 (ODD)	
5	RXO2-	Negative Transmission data of Pixel 2 (ODD)	
6	RXO2+	Positive Transmission data of Pixel 2 (ODD)	
7	BIST	BIST Function	
8	RXOC-	Negative Transmission Clock (ODD)	
9	RXOC+	Positive Transmission Clock (ODD)	
10	RXO3-	Negative Transmission data of Pixel 3 (ODD)	
11	RXO3+	Positive Transmission data of Pixel 3 (ODD)	
12	RXE0-	Negative Transmission data of Pixel 0 (EVEN)	
13	RXE0+	Positive Transmission data of Pixel 0 (EVEN)	
14	GND	Power Ground	
15	RXE1-	Negative Transmission data of Pixel 1 (EVEN)	
16	RXE1+	Positive Transmission data of Pixel 1 (EVEN)	
17	GND	Power Ground	
18	RXE2-	Negative Transmission data of Pixel 2 (EVEN)	
19	RXE2+	Positive Transmission data of Pixel 2 (EVEN)	
20	RXEC-	Negative Transmission Clock (EVEN)	
21	RXEC+	Positive Transmission Clock (EVEN)	
22	RXE3-	Negative Transmission data of Pixel 3 (EVEN)	
23	RXE3+	Positive Transmission data of Pixel 3 (EVEN)	
24	GND	Power Ground	
25	SCL	CTL_DVR for LCD manufacturer	
26	SDA	CE_DVR for LCD manufacturer	
27	NC	No connection	
28	VDD	Power Supply: +12V	
29	VDD	Power Supply: +12V	
30	VDD	Power Supply: +12V	

BLU pin:

No.	Color	Function
1	Red	LED Anode
2	Green	LED Cathode

9. Signal Timing Specification

9.1. Timing Parameters (DE only mode)

Item		Symbols	Min	Typ	Max	Unit	
Clock	Frequency	1/Tc	60	74.25	78	MHz	
	High Time	Tch	-	4/7Tc	-		
	Low Time	Tcl	-	3/7Tc	-		
Frame Period		Tv	1100	1125	1149	lines	
			48.5	60	63	Hz	
Horizontal Active Display Term		Valid	t _{HV}	-	960	-	t _{CLK}
		Total	t _{HP}	1060	1100	1200	t _{CLK}
Vertical Active Display Term		Valid	t _{VV}	-	1080	-	t _{HP}
		Total	t _{VP}	1100	1125	1149	t _{HP}

Notes: This product is DE only mode. The input of Hsync & Vsync signal does not have an effect on normal operation.

Symbol	Parameter	Condition	Min	Typ	Max	Unit
F	LVDS Input frequency	-	60	74.25	78	MHz
T _{LVSK}	LVDS channel to channel skew	F=100MHz V _{IC} =1.2V V _{ID} =±400mV	-380	-	+380	ps
F _{LVMOD}	Modulating frequency of input clock during SSC		60	-	85	KHz
F _{LVDEV}	Maximum deviation of input clock frequency during SSC		-3	-	+3	%
T _{CY-CY}	Cycle to Cycle jitter		-	-	100	ps

9.2. Signal Timing Waveform

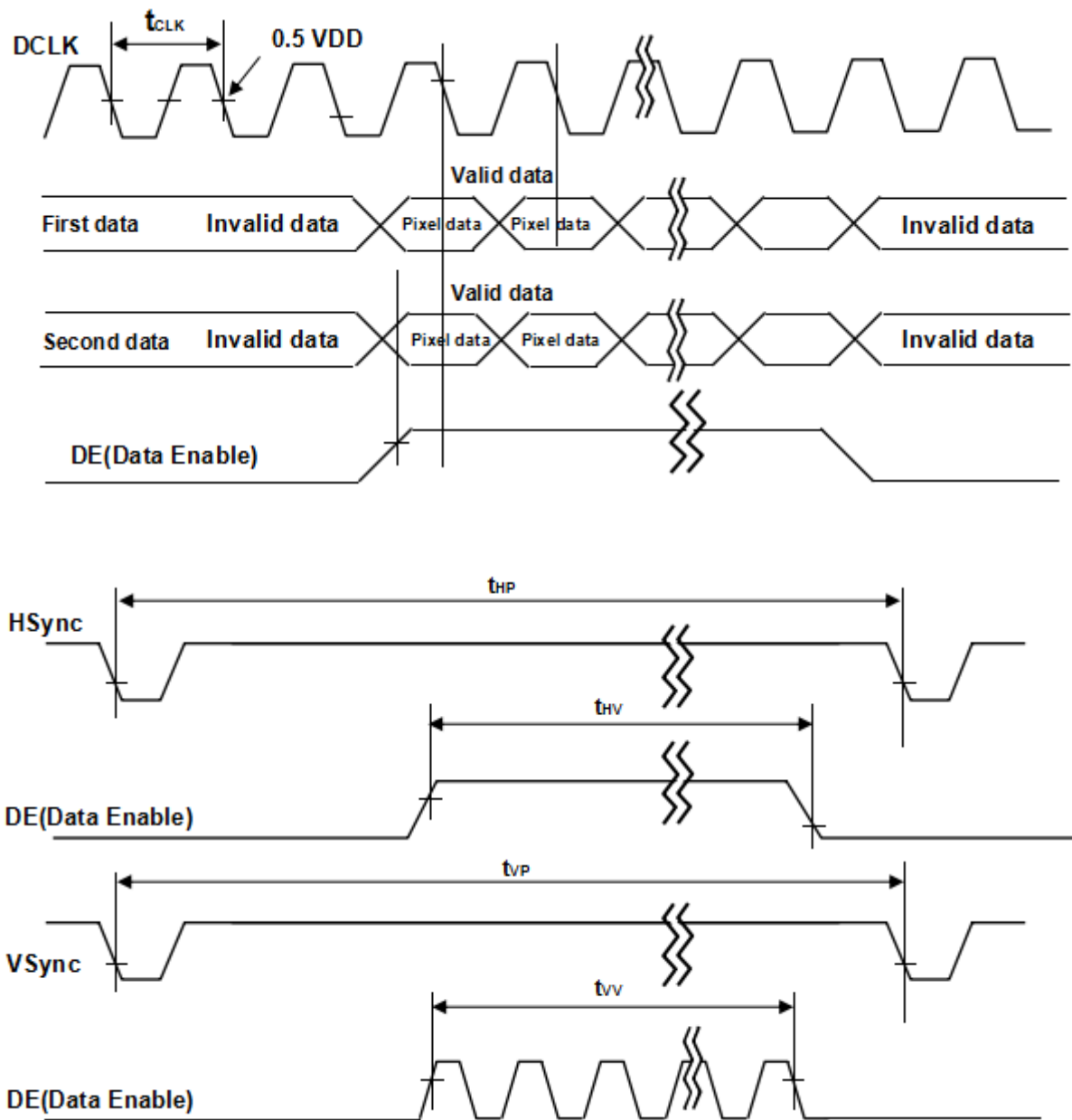

10. Power Sequence

To prevent a latch-up or DC operation of the Open Cell, the power on/off sequence shall be as shown in below.

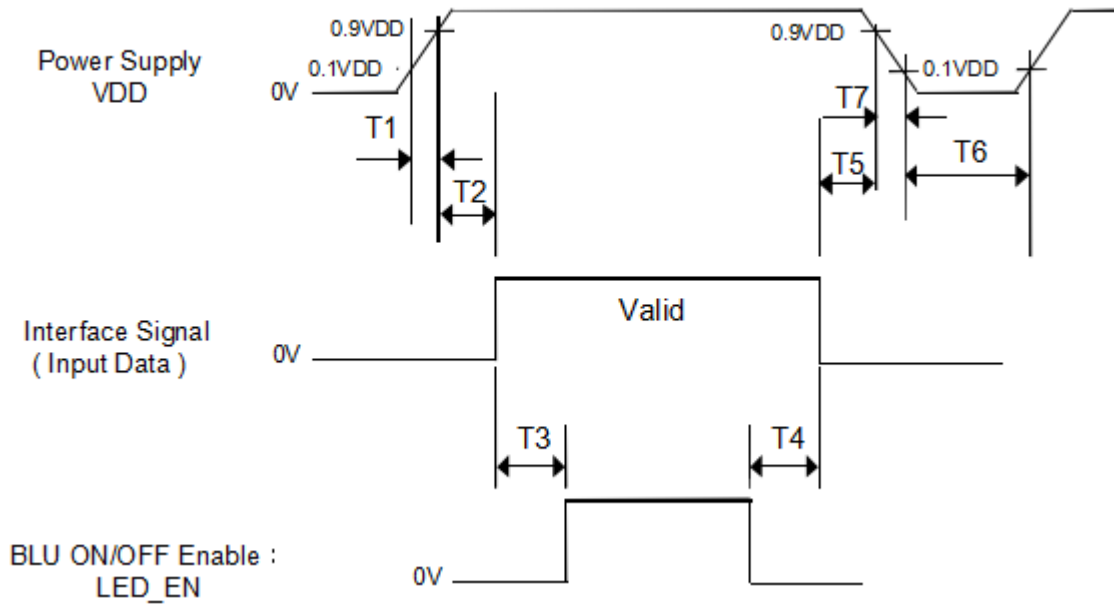

Parameter	Values			Units
	Min	Typ	Max	
T1	0.5	-	20	ms
T2	10	-	100	ms
T3	200	-	-	ms
T4	200	-	-	ms
T5	0	-	-	ms
T6	1	-	-	s

- Notes:
1. Back Light must be turn on after power for logic and interface signal are valid.
 2. Even though T1 is out of SPEC, it is still ok if the inrush current of VDD is below the limit.
 3. When $VDD < 0.9VDD(Typ.)$, Power off.
 4. T7 decreases smoothly, if there were rebounding voltage, it must smaller than 5 volts.

11. Quality Assurance

11.1.Purpose

This standard for Quality Assurance assures the quality of LCD module products supplied to customer.

11.2.Standard for Quality Test

11.2.1. Sampling Plan:

GB2828.1-2012

Single sampling, general inspection level II

11.2.2. Sampling Criteria:

Visual inspection: AQL 1.5

Electrical functional: AQL 0.65.

11.2.3. Reliability Test:

Detailed requirement refer to Reliability Test Specification.

11.3.Nonconforming Analysis & Disposition

11.3.1. Nonconforming analysis:

11.3.1.1. Customer should provide overall information of non-conforming sample for their complaints.

11.3.1.2. After receipt of detailed information from customer, the analysis of nonconforming parts usually should be finished in one week.

11.3.1.3. If cannot finish the analysis on time, customer will be notified with the progress status.

11.3.2. Disposition of nonconforming:

11.3.2.1. Non-conforming product over PPM level will be replaced.

11.3.2.2. The cause of non-conformance will be analyzed. Corrective action will be discussed and implemented.

11.4.Agreement Items

Shall negotiate with customer if the following situation occurs:

11.4.1. There is any discrepancy in standard of quality assurance.

11.4.2. Additional requirement to be added in product specification.

11.4.3. Any other special problem.

11.5. Standard of the Product Visual Inspection

11.5.1. Appearance inspection:

11.5.1.1. The inspection must be under illumination about 1000 – 1500 lx, and the distance of view must be at 30cm ± 2cm.

11.5.1.2. The viewing angle should be 45° from the vertical line without reflection light or follows customer's viewing angle specifications.

11.5.1.3. Definition of area: A Zone: Active Area, B Zone: Viewing Area,

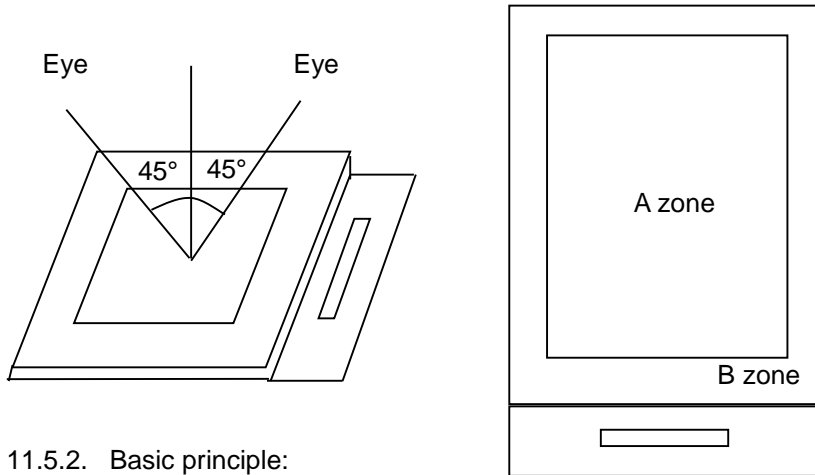

11.5.2. Basic principle:

11.5.2.1. A set of sample to indicate the limit of acceptable quality level must be discussed by both us and customer when there is any dispute happened.

11.5.2.2. New item must be added on time when it is necessary.

11.6. Inspection Specification for the TFT module

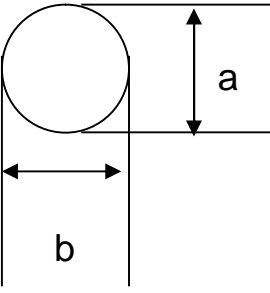
No.	Item	Criteria (Unit: mm)												
01	Black / White Spot Foreign Material (Round Type) Pinholes Stain Particles Inside Cell. (Minor Defect)	 <p>$\phi = (a + b) / 2$</p> <p>Distance between 2 defects should more than 5mm apart.</p> <table border="1" data-bbox="909 1377 1412 1590"> <thead> <tr> <th>Size</th> <th>Area</th> <th>Acc. Qty</th> </tr> </thead> <tbody> <tr> <td>$\phi \leq 0.20$</td> <td></td> <td>Ignore</td> </tr> <tr> <td>$0.20 < \phi \leq 0.50$</td> <td></td> <td>$N \leq 3$</td> </tr> <tr> <td>$0.50 < \phi$</td> <td></td> <td>0</td> </tr> </tbody> </table>	Size	Area	Acc. Qty	$\phi \leq 0.20$		Ignore	$0.20 < \phi \leq 0.50$		$N \leq 3$	$0.50 < \phi$		0
Size	Area	Acc. Qty												
$\phi \leq 0.20$		Ignore												
$0.20 < \phi \leq 0.50$		$N \leq 3$												
$0.50 < \phi$		0												

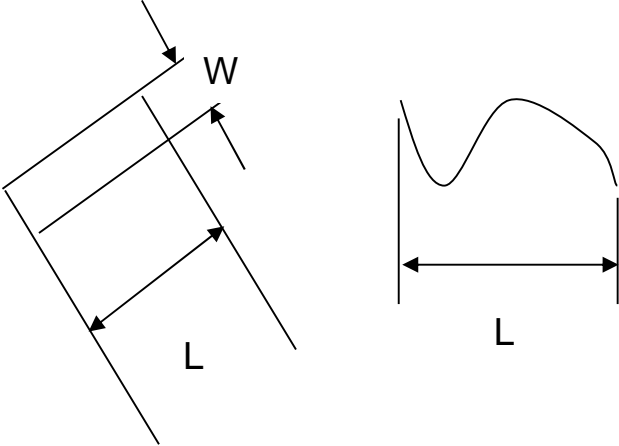
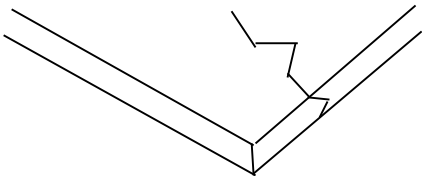
02	Electrical Defect (Minor Defect)	<table border="1" data-bbox="552 226 1417 443"> <tr> <th data-bbox="552 226 858 309">Bright dot</th> <th data-bbox="858 226 1075 309">Display Area</th> <th data-bbox="1075 226 1283 309">Total</th> <td data-bbox="1283 226 1417 398" rowspan="3">Note1</td> </tr> <tr> <td data-bbox="552 309 858 353"></td> <td data-bbox="858 309 1075 353">$N \leq 2$</td> <td data-bbox="1075 309 1283 353">$N \leq 2$</td> </tr> <tr> <td data-bbox="552 353 858 398">Dark dot</td> <td data-bbox="858 353 1075 398">$N \leq 4$</td> <td data-bbox="1075 353 1283 398">$N \leq 4$</td> </tr> <tr> <td data-bbox="552 398 858 443">Total dot</td> <td data-bbox="858 398 1075 443">$N \leq 4$</td> <td data-bbox="1075 398 1283 443">$N \leq 4$</td> <td data-bbox="1283 398 1417 443" rowspan="2">Note 2</td> </tr> <tr> <td data-bbox="552 443 858 488">Mura</td> <td colspan="2" data-bbox="858 443 1283 488">Not visible through 5% ND filters.</td> </tr> </table> <p data-bbox="552 454 655 483">Remark:</p> <p data-bbox="552 490 1362 519">1. Bright dot caused by scratch and foreign object accords to item 1.</p>	Bright dot	Display Area	Total	Note1		$N \leq 2$	$N \leq 2$	Dark dot	$N \leq 4$	$N \leq 4$	Total dot	$N \leq 4$	$N \leq 4$	Note 2	Mura	Not visible through 5% ND filters.	
Bright dot	Display Area	Total	Note1																
	$N \leq 2$	$N \leq 2$																	
Dark dot	$N \leq 4$	$N \leq 4$																	
Total dot	$N \leq 4$	$N \leq 4$	Note 2																
Mura	Not visible through 5% ND filters.																		
03	Black and White Line Scratch Foreign Material (Line Type) (Minor Defect)	 <table border="1" data-bbox="611 1066 1235 1330"> <thead> <tr> <th data-bbox="611 1066 783 1155">Length</th> <th data-bbox="783 1066 1094 1155">Width</th> <th data-bbox="1094 1066 1235 1155">Acc. Qty</th> </tr> </thead> <tbody> <tr> <td data-bbox="611 1155 783 1200">/</td> <td data-bbox="783 1155 1094 1200">$W \leq 0.1$</td> <td data-bbox="1094 1155 1235 1200">Ignore</td> </tr> <tr> <td data-bbox="611 1200 783 1245">$L \leq 2.5$</td> <td data-bbox="783 1200 1094 1245">$0.1 < W \leq 0.2$</td> <td data-bbox="1094 1200 1235 1245">3</td> </tr> <tr> <td data-bbox="611 1245 783 1290">$L > 2.5$</td> <td data-bbox="783 1245 1094 1290">$0.2 < W$</td> <td data-bbox="1094 1245 1235 1290">0</td> </tr> <tr> <td colspan="2" data-bbox="611 1290 1094 1330">Total</td> <td data-bbox="1094 1290 1235 1330">3</td> </tr> </tbody> </table> <p data-bbox="552 1375 1417 1453">Distance between 2 defects should more than 3mm apart. Scratches not viewable through the back of the display are acceptable.</p>	Length	Width	Acc. Qty	/	$W \leq 0.1$	Ignore	$L \leq 2.5$	$0.1 < W \leq 0.2$	3	$L > 2.5$	$0.2 < W$	0	Total		3		
Length	Width	Acc. Qty																	
/	$W \leq 0.1$	Ignore																	
$L \leq 2.5$	$0.1 < W \leq 0.2$	3																	
$L > 2.5$	$0.2 < W$	0																	
Total		3																	
04	Glass Crack (Minor Defect)	 <p data-bbox="552 1749 1177 1783">Crack is potential to enlarge, any type is not allowed.</p>																	

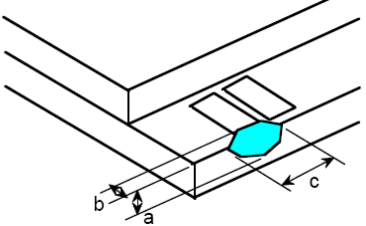
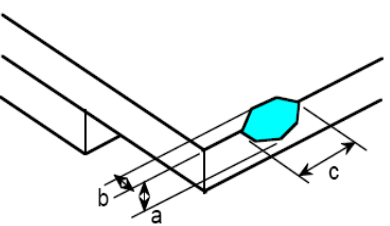
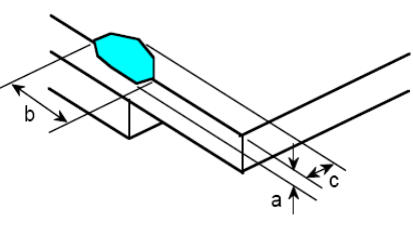
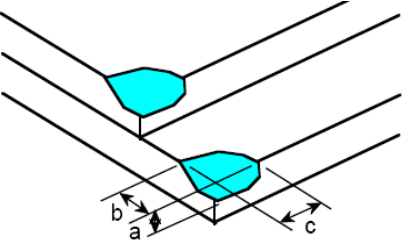
<p>05</p>	<p>Glass Chipping Pad Area: (Minor Defect)</p> 	<table border="1"> <thead> <tr> <th>Length and Width</th> <th>Acc. Qty</th> </tr> </thead> <tbody> <tr> <td>$c > 3.0, b < 1.0$</td> <td>1</td> </tr> <tr> <td>$c < 3.0, b < 1.0$</td> <td>3</td> </tr> <tr> <td colspan="2">a < Glass Thickness</td> </tr> </tbody> </table>	Length and Width	Acc. Qty	$c > 3.0, b < 1.0$	1	$c < 3.0, b < 1.0$	3	a < Glass Thickness			
Length and Width	Acc. Qty											
$c > 3.0, b < 1.0$	1											
$c < 3.0, b < 1.0$	3											
a < Glass Thickness												
<p>06</p>	<p>Glass Chipping Rear of Pad Area: (Minor Defect)</p> 	<table border="1"> <thead> <tr> <th>Length and Width</th> <th>Acc. Qty</th> </tr> </thead> <tbody> <tr> <td>$c > 3.0, b < 1.0$</td> <td>1</td> </tr> <tr> <td>$c < 3.0, b < 1.0$</td> <td>2</td> </tr> <tr> <td>$c < 3.0, b < 0.5$</td> <td>4</td> </tr> <tr> <td colspan="2">a < Glass Thickness</td> </tr> </tbody> </table>	Length and Width	Acc. Qty	$c > 3.0, b < 1.0$	1	$c < 3.0, b < 1.0$	2	$c < 3.0, b < 0.5$	4	a < Glass Thickness	
Length and Width	Acc. Qty											
$c > 3.0, b < 1.0$	1											
$c < 3.0, b < 1.0$	2											
$c < 3.0, b < 0.5$	4											
a < Glass Thickness												
<p>07</p>	<p>Glass Chipping Except Pad Area: (Minor Defect)</p> 	<table border="1"> <thead> <tr> <th>Length and Width</th> <th>Acc. Qty</th> </tr> </thead> <tbody> <tr> <td>$c > 3.0, b < 1.0$</td> <td>1</td> </tr> <tr> <td>$c < 3.0, b < 1.0$</td> <td>2</td> </tr> <tr> <td>$c < 3.0, b < 0.5$</td> <td>4</td> </tr> <tr> <td colspan="2">a < Glass Thickness</td> </tr> </tbody> </table>	Length and Width	Acc. Qty	$c > 3.0, b < 1.0$	1	$c < 3.0, b < 1.0$	2	$c < 3.0, b < 0.5$	4	a < Glass Thickness	
Length and Width	Acc. Qty											
$c > 3.0, b < 1.0$	1											
$c < 3.0, b < 1.0$	2											
$c < 3.0, b < 0.5$	4											
a < Glass Thickness												
<p>08</p>	<p>Glass Corner Chipping: (Minor Defect)</p> 	<table border="1"> <thead> <tr> <th>Length and Width</th> <th>Acc. Qty</th> </tr> </thead> <tbody> <tr> <td>$c < 3.0, b < 3.0$</td> <td>Ignore</td> </tr> <tr> <td colspan="2">a < Glass Thickness</td> </tr> </tbody> </table>	Length and Width	Acc. Qty	$c < 3.0, b < 3.0$	Ignore	a < Glass Thickness					
Length and Width	Acc. Qty											
$c < 3.0, b < 3.0$	Ignore											
a < Glass Thickness												

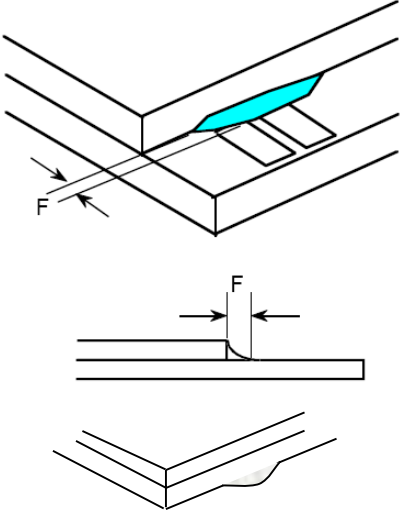
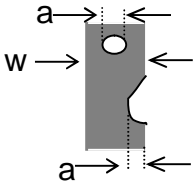
<p>09</p>	<p>Glass Burr: (Minor Defect)</p> 	<table border="1" data-bbox="868 264 1339 353"> <thead> <tr> <th>Length</th> <th>Acc. Qty</th> </tr> </thead> <tbody> <tr> <td>$F < 1.0$</td> <td>Ignore</td> </tr> </tbody> </table> <p>Glass burr don't affect assemble and module dimension.</p>	Length	Acc. Qty	$F < 1.0$	Ignore				
Length	Acc. Qty									
$F < 1.0$	Ignore									
<p>10</p>	<p>FPC Defect: (Minor Defect)</p> 	<p>10.1 Dent, pinhole width $a < w/3$. (w: circuitry width.) 10.2 Open circuit is unacceptable. 10.3 No oxidation, contamination and distortion.</p>								
<p>11</p>	<p>Bubble on Polarizer (Minor Defect)</p>	<table border="1" data-bbox="743 1301 1214 1473"> <thead> <tr> <th>Diameter</th> <th>Acc. Qty</th> </tr> </thead> <tbody> <tr> <td>$\varphi \leq 0.30$</td> <td>Ignore</td> </tr> <tr> <td>$0.30 < \varphi \leq 0.50$</td> <td>$N \leq 2$</td> </tr> <tr> <td>$0.50 < \varphi$</td> <td>$N = 0$</td> </tr> </tbody> </table>	Diameter	Acc. Qty	$\varphi \leq 0.30$	Ignore	$0.30 < \varphi \leq 0.50$	$N \leq 2$	$0.50 < \varphi$	$N = 0$
Diameter	Acc. Qty									
$\varphi \leq 0.30$	Ignore									
$0.30 < \varphi \leq 0.50$	$N \leq 2$									
$0.50 < \varphi$	$N = 0$									
<p>12</p>	<p>Dent on Polarizer (Minor Defect)</p>	<table border="1" data-bbox="743 1543 1214 1715"> <thead> <tr> <th>Diameter</th> <th>Acc. Qty</th> </tr> </thead> <tbody> <tr> <td>$\varphi \leq 0.25$</td> <td>Ignore</td> </tr> <tr> <td>$0.25 < \varphi \leq 0.50$</td> <td>$N \leq 4$</td> </tr> <tr> <td>$0.50 < \varphi$</td> <td>None</td> </tr> </tbody> </table>	Diameter	Acc. Qty	$\varphi \leq 0.25$	Ignore	$0.25 < \varphi \leq 0.50$	$N \leq 4$	$0.50 < \varphi$	None
Diameter	Acc. Qty									
$\varphi \leq 0.25$	Ignore									
$0.25 < \varphi \leq 0.50$	$N \leq 4$									
$0.50 < \varphi$	None									
<p>13</p>	<p>Bezel</p>	<p>13.1 No rust, distortion on the Bezel. 13.2 No visible fingerprints, stains or other contamination.</p>								

14	PCB	14.1 No distortion or contamination on PCB terminals. 14.2 All components on PCB must same as documented on the BOM/component layout. 14.3 Follow IPC-A-600F.
15	Soldering	Follow IPC-A-610C standard
16	Electrical Defect (Major defect)	The below defects must be rejected. 16.1 Missing vertical / horizontal segment, 16.2 Abnormal Display. 16.3 No function or no display. 16.4 Current exceeds product specifications. 16.5 LCD viewing angle defect. 16.6 No Backlight. 16.7 Dark Backlight. 16.8 Touch Panel no function.

Remark: LCD Panel Broken shall be rejected. Defect out of LCD viewing area is acceptable.

11.7. Classification of Defects

- 11.7.1. Visual defects (Except no / wrong label) are treated as minor defect and electrical defect is major.
- 11.7.2. Two minor defects are equal to one major in lot sampling inspection.

11.8. Identification/marketing criteria

Any unit with illegible / wrong /double or no marking/ label shall be rejected.

11.9. Packing

- 11.9.1. There should be no damage of the outside carton box, each packaging box should have one identical label.
- 11.9.2. Modules inside package box should have compliant mark.
- 11.9.3. All direct package materials shall offer ESD protection.

Note1: Bright dot is defined as the defective area of the dot is larger than 50% of one sub-pixel area.

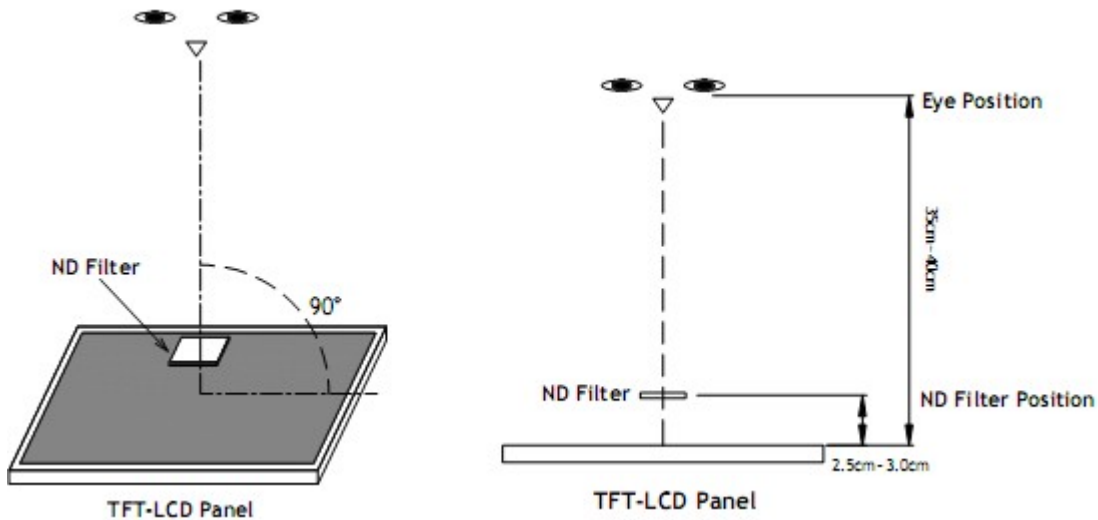

Bright dot: The bright dot size defect at black display pattern. It can be recognized by 2% transparency of filter when the distance between eyes and panel is 350mm± 50mm.

Dark dot: Cyan, Magenta or Yellow dot size defect at white display pattern. It can be recognized by 5% transparency of filter when the distance between eyes and panel is 350mm± 50mm.

Note2: Mura on display which appears darker / brighter against background brightness on parts of display area.

12. Reliability Specification

No	Item	Condition	Quantity	Criteria
1	High Temperature Operating	50°C, 96Hrs	2	GB/T2423.2-2008
2	Low Temperature Operating	0°C, 96Hrs	2	GB/T2423.1-2008
3	High Humidity	50°C, 80%RH, 96Hrs	2	GB/T2423.3-2016
4	High Temperature Storage	60°C, 96Hrs	2	GB/T2423.2-2008
5	Low Temperature Storage	-20°C, 96Hrs	2	GB/T2423.1-2008
6	Thermal Cycling Test	-20°C, 60min~60°C, 60min, 20 cycles.	2	GB/T2423.22-2012
7	Packing Vibration	Frequency range:10Hz~50Hz Acceleration of gravity:1.5G X, Y, Z 30 min for each direction.	2	GB/T5170.14-2009
8	Electrical Static Discharge	Air: ± 4kV 150pF/330 Ω 5 times Contact: ± 2kV 150pF/330 Ω 5 times	2	GB/T17626.2-2018
9	Drop Test (Packaged)	Height:80 cm,1 corner, 3 edges, 6 surfaces.	2	GB/T2423.8-1995

Note1. No deflection cosmetic and operational function allowable.

Note2. Total current Consumption should be below double of initial value

13. Precautions and Warranty

13.1.Safety

- 13.1.1. The liquid crystal in the LCD is poisonous. Do not put it in your mouth. If the liquid crystal touches your skin or clothes, wash it off immediately using soap and water.
- 13.1.2. Since the liquid crystal cells are made of glass, do not apply strong impact on them. Handle with care.

13.2.Handling

- 13.2.1. Reverse and use within ratings in order to keep performance and prevent damage.
- 13.2.2. Do not wipe the polarizer with dry cloth, as it might cause scratch. If the surface of the LCD needs to be cleaned, wipe it swiftly with cotton or other soft cloth soaked with petroleum IPA, do not use other chemicals.

13.3.Storage

- 13.3.1. Do not store the LCD module beyond the specified temperature ranges.
- 13.3.2. Strong light exposure causes degradation of polarizer and color filter.

13.4.Metal Pin (Apply to Products with Metal Pins)

13.4.1. Pins of LCD and Backlight

13.4.1.1. Solder tip can touch and press on the tip of Pin LEAD during the soldering

13.4.1.2. Recommended Soldering Conditions

Solder Type: Sn96.3~94-Ag3.3~4.3-Cu0.4~1.1

Maximum Solder Temperature: 370°C

Maximum Solder Time: 3s at the maximum temperature

Recommended Soldering Temp: 350±20°C

Typical Soldering Time: ≤3s

13.4.1.3. Solder Wetting

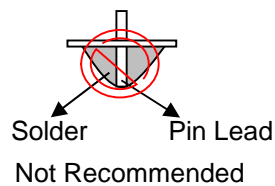
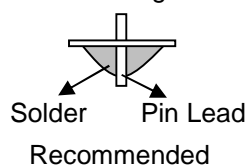

13.4.2. Pins of EL

13.4.2.1. Solder tip can touch and press on the tip of EL leads during soldering.

13.4.2.2. No Solder Paste on the soldering pad on the motherboard is recommended.

13.4.2.3. Recommended Soldering Conditions

Solder type: Nippon Alimit Leadfree SR-34, size 0.5mm

Recommended Solder Temperature: 270~290°C

Typical Soldering Time: ≤2s

Minimum solder distance from EL lamp (body):2.0mm

- 13.4.2.4. No horizontal press on the EL leads during soldering.
- 13.4.2.5. 180° bend EL leads three times is not allowed.
- 13.4.2.6. Solder Wetting

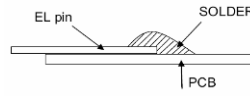

Recommended

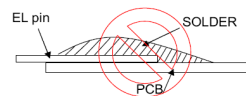

Not Recommended

- 13.4.2.7. The type of the solder iron:

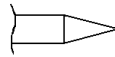

Recommended

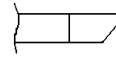

Not Recommended

- 13.4.2.8. Solder Pad

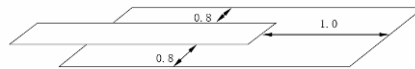

13.5.Operation

- 13.5.1. Do not drive LCD with DC voltage
- 13.5.2. Response time will increase below lower temperature
- 13.5.3. Display may change color with different temperature
- 13.5.4. Mechanical disturbance during operation, such as pressing on the display area, may cause the segments to appear “fractured”.
- 13.5.5. Do not connect or disconnect the LCM to or from the system when power is on.
- 13.5.6. Never use the LCM under abnormal condition of high temperature and high humidity.
- 13.5.7. Module has high frequency circuits. Sufficient suppression to the electromagnetic interface shall be done by system manufacturers. Grounding and shielding methods may be important to minimize the interference.
- 13.5.8. Do not display the fixed pattern for long time (we suggest the time not longer than one hour) because it may develop image sticking due to the TFT structure.

13.6.Static Electricity

- 13.6.1. CMOS LSIs are equipped in this unit, so care must be taken to avoid the electro-static charge, by ground human body, etc.
- 13.6.2. The normal static prevention measures should be observed for work clothes and benches.
- 13.6.3. The module should be kept into anti-static bags or other containers resistant to static for storage.

13.7.Limited Warranty

- 13.7.1. Our warranty liability is limited to repair and/or replacement. We will not be responsible for any consequential loss.
- 13.7.2. If possible, we suggest customer to use up all modules in six months. If the module storage time over twelve months, we suggest that recheck it before the module be used.
- 13.7.3. After the product shipped, any product quality issues must be feedback within three months, otherwise, we will not be responsible for the subsequent or consequential events.

14. Outline Drawing

