

Display Elektronik GmbH

# DATA SHEET

*TFT MODULE*

**DEM 128128A1 TMH-PW-N  
(C-TOUCH)**

**1,44" TFT + PCT**

Product Specification

Ver.: 3

27.03.2019

**Revision History**

<b>Revision</b>	<b>Date</b>	<b>Originator</b>	<b>Detail</b>	<b>Remarks</b>
0	28.12.2018	CK	Initial Release	
1	10.01.2019	ZDT	Modify Interface Modify Uniformity	P4 P5
2	25.01.2019	MHI	Modify Touch Screen Panel Specifications Modify Outline Drawing	P6 P27
3	27.03.2019	MHI	Add Weight Add Current Consumption Modify Chromaticity Transmissive Modify Outline Drawing	P4 P5 P7 P27

**Table of Contents**

No.	Item	Page
1.	General Description .....	4
2.	Module Parameter .....	4
3.	Absolute Maximum Ratings .....	4
4.	DC Characteristics .....	5
5.	Backlight Characteristic .....	5
5.1.	Backlight Characteristics.....	5
5.2.	Backlighting circuit .....	5
6.	Touch Screen Panel Specifications.....	6
7.	Optical Characteristics .....	6
7.1.	Optical Characteristics .....	6
7.2.	Definition of Response Time .....	7
7.3.	Definition of Contrast Ratio .....	8
7.4.	Definition of Viewing Angles.....	8
7.5.	Definition of Color Appearance .....	9
7.6.	Definition of Surface Luminance, Uniformity and Transmittance.....	9
8.	Block Diagram and Power Supply .....	10
9.	Interface Pins Definition .....	11
10.	AC Characteristics .....	12
10.1.	8080-series Parallel Interface .....	12
10.2.	Serial Interface Characteristics (3-line Serial) .....	14
11.	Quality Assurance .....	15
11.1.	Purpose.....	15
11.2.	Standard for Quality Test.....	15
11.3.	Nonconforming Analysis & Disposition .....	15
11.4.	Agreement Items.....	15
11.5.	Standard of the Product Visual Inspection .....	16
11.6.	Inspection Specification .....	16
11.7.	Classification of Defects.....	23
11.8.	Identification/marketing criteria .....	23
11.9.	Packing .....	23
12.	Reliability Specification .....	24
13.	Precautions and Warranty .....	24
13.1.	Safety .....	24
13.2.	Handling.....	24
14.	Precautions and Warranty .....	25
14.1.	Safety .....	25
14.2.	Handling .....	25
14.3.	Storage.....	25
14.4.	Metal Pin (Apply to Products with Metal Pins) .....	25
14.5.	Operation .....	26
14.6.	Static Electricity .....	26
14.7.	Limited Warranty .....	26
15.	Outline Drawing .....	27

**1. General Description**

The specification is a transmissive type color active matrix liquid crystal display (LCD) which uses amorphous thin film transistor (TFT) as switching devices. This product is composed of a TFT-LCD panel, driver IC, a touch panel and a backlight unit.

**2. Module Parameter**

Features	Details	Unit
Display Size(Diagonal)	1.44"	-
LCD Type	TN TFT	-
Display Mode	Transmissive /Normally white	-
Resolution	128 RGB x 128	Pixels
View Direction	6 O'clock	Best Image
Gray Scale Inversion Direction	12 O'clock	-
Module Outline	36.70 x 43.00 x 4.15 (Note1 )	mm
Active Area	25.50 x 26.50	mm
Pixel Size	0.1992 x 0.2070	mm
Pixel Arrangement	RGB Stripe	-
Display Colors	262K	-
Interface	8080 / 8 bit-MCU Interface 3-line Serial Interface	-
Driver IC	ST7735S (Sitronix)	-
With or without Touch Panel	With CTP	-
Operating Temperature	-20~70	°C
Storage Temperature	-30~80	°C
Weight	9	g

Note 1: Exclusive hooks, posts, FFC/FPC tail etc.

**3. Absolute Maximum Ratings**

$V_{SS}=0V, T_a=25^{\circ}C$

Item	Symbol	Min.	Max.	Unit
Supply Voltage	VDD	-0.3	4.8	V
Supply Voltage(Logic)	VDDIO	-0.3	4.6	V
Storage Temperature	T <sub>stg</sub>	-30	+80	°C
Operating Temperature	T <sub>op</sub>	-20	+70	°C

Note 1: If  $T_a$  below  $50^{\circ}C$ , the maximal humidity is 90%RH, if  $T_a$  over  $50^{\circ}C$ , absolute humidity should be less than 60%RH.

Note 2: The response time will be extremely slow when the operating temperature is around  $-10^{\circ}C$ , and the back ground will become darker at high temperature operating.

**4. DC Characteristics**

Item	Symbol	Min.	Typ.	Max.	Unit
Supply Voltage	VDD	2.5	2.8	4.8	V
	VDDIO	1.65	1.8	3.7	V
Logic Low input voltage	V <sub>IL</sub>	0	-	0.3*VDDIO	V
Logic High input voltage	V <sub>IH</sub>	0.7*VDDIO	-	VDDIO	V
Logic Low output voltage	V <sub>OL</sub>	GND	-	0.2*VDDIO	V
Logic High output voltage	V <sub>OH</sub>	0.8*VDDIO	-	VDDIO	V
Current Consumption Normal Mode	I <sub>cc</sub>	-	3	-	mA

**5. Backlight Characteristic**

**5.1. Backlight Characteristics**

Item	Symbol	Condition	Min.	Typ.	Max.	Unit
Forward Voltage	V <sub>F</sub>	T <sub>a</sub> =25 °C, I <sub>F</sub> =20mA/LED	2.8	3.2	3.4	V
Forward Current	I <sub>F</sub>	T <sub>a</sub> =25 °C, V <sub>F</sub> =3.2V/LED	-	40	-	mA
Power Dissipation	P <sub>d</sub>		-	128	-	mW
LED Lifetime	-	-	20000	30000		hrs
Uniformity	Avg		80	85	-	%
Drive Method	Constant current					
LED Configuration	2 White LEDS in parallel					

Note: LED life time defined as follows: The final brightness is at 50% of original brightness.

The environmental conducted under ambient air flow, at T<sub>a</sub>=25°C ± 2 °C, 60%RH ± 5%, I<sub>F</sub>=20mA/LED.

**5.2. Backlighting Circuit**

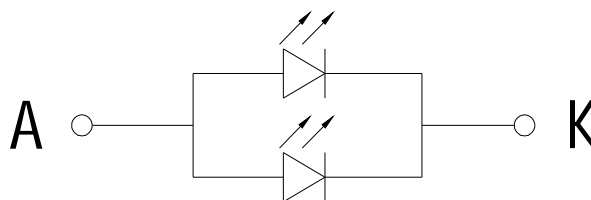

6. Touch Screen Panel Specifications

Item	CTP Description				
1	IC	FT6336G			
2	Interface	IIC			
3	Operation Voltage	2.8 ~ 3.3V			
4	Interface Signal Voltage	2.8 ~ 3.3V			
5	Surface Hardness	6H			
6	Operation Temperature	-20°C ~ +70°C			
7	Storage Temperature	-30°C ~ +80°C			
8	Strengthened Type	Chemical	Item	Main Layer Define	Thickness /Materials
9	Transmittance	85%	1	Lens	0.7mm / Glass
10	Origin of Coordinates	T/L	2	Optical Glue	0.125mm
11	Resolution Ratio	128x128	3	Sensor	0.125mm / Film

7. Optical Characteristics

7.1. Optical Characteristics

Ta=25°C, V<sub>DD</sub>=2.8V,

	Item	Symbol	Condition	Specification			Unit	
				Min.	Typ.	Max.		
Backlight On (Transmissive Mode)	Luminance on TFT(I <sub>f</sub> =20mA/LED)	Lv	Normally viewing angle θ <sub>x</sub> = φ <sub>y</sub> = 0°	350	440	-	cd/m <sup>2</sup>	
	Contrast Ratio(See 7.3)	CR		-	350	-		
	Response Time (See 7.2)	TR+TF		-	25	40	ms	
	Chromaticity Transmissive (See 7.5)	Red	X <sub>R</sub>	Center CR≥10	0.505	0.555	0.605	
			Y <sub>R</sub>		0.256	0.306	0.356	
		Green	X <sub>G</sub>		0.258	0.308	0.358	
			Y <sub>G</sub>		0.552	0.602	0.652	
		Blue	X <sub>B</sub>		0.094	0.144	0.194	
			Y <sub>B</sub>		0.035	0.085	0.135	
	White	X <sub>W</sub>	0.208	0.258	0.308			
		Y <sub>W</sub>	0.235	0.285	0.335			
	Viewing Angle (See 7.4)	Horizontal	θ <sub>x+</sub>	Center CR≥10	35	45	-	Deg.
			θ <sub>x-</sub>		35	45	-	
Vertical		φ <sub>y+</sub>	35		45	-		
		φ <sub>y-</sub>	15		25	-		
NTSC Ratio(Gamut)				-	53	-	%	

**7.2. Definition of Response Time**

**7.2.1. Normally Black Type (Negative)**

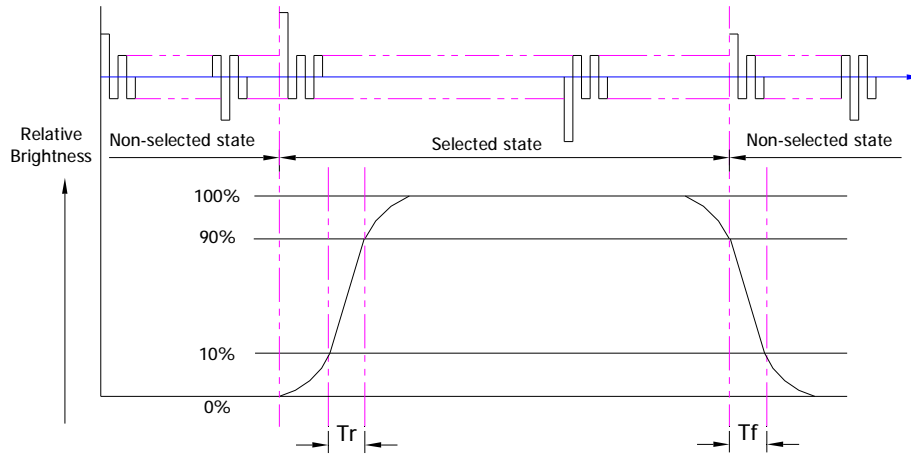

Tr is the time it takes to change from non-selected stage with relative luminance 10% to selected state with relative luminance 90%;

Tf is the time it takes to change from selected state with relative luminance 90% to non-selected state with relative luminance 10%.

Note: Measuring machine: LCD-5100

**7.2.2. Normally White Type (Positive)**

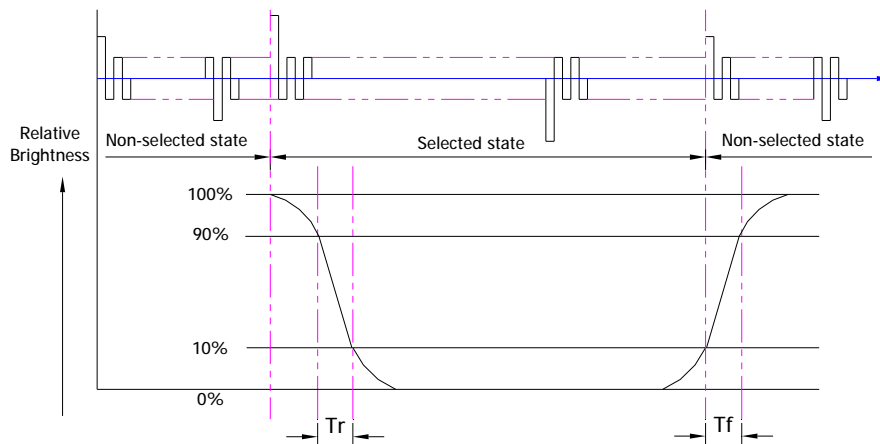

Tr is the time it takes to change from non-selected stage with relative luminance 90% to selected state with relative luminance 10%;

Tf is the time it takes to change from selected state with relative luminance 10% to non-selected state with relative luminance 90%;

Note: Measuring machine: LCD-5100 or EQUI

**7.3. Definition of Contrast Ratio**

Contrast is measured perpendicular to display surface in reflective and transmissive mode.

The measurement condition is:

Measuring Equipment	Eldim or Equivalent
Measuring Point Diameter	3mm//1mm
Measuring Point Location	Active Area centre point
Test Pattern	A: All Pixels white B: All Pixel black
Contrast Setting	Maximum

Definitions: CR (Contrast) = Luminance of White Pixel / Luminance of Black Pixel

**7.4. Definition of Viewing Angles**

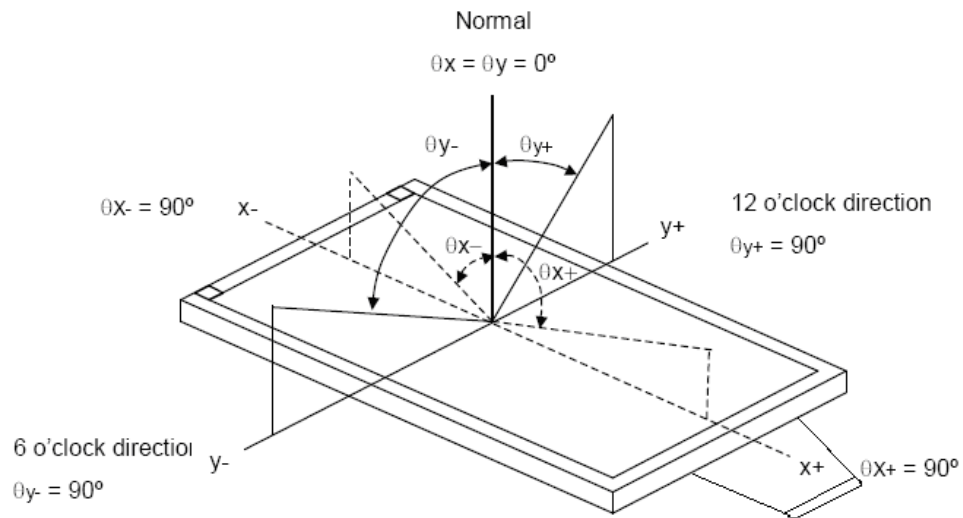

Measuring machine: LCD-5100 or EQUI



**7.5. Definition of Color Appearance**

R, G, B and W are defined by (x, y) on the IE chromaticity diagram

NTSC=area of RGB triangle/area of NTSC triangleX100%

Measuring picture: Red, Green, Blue and White (Measuring machine: BM-7)

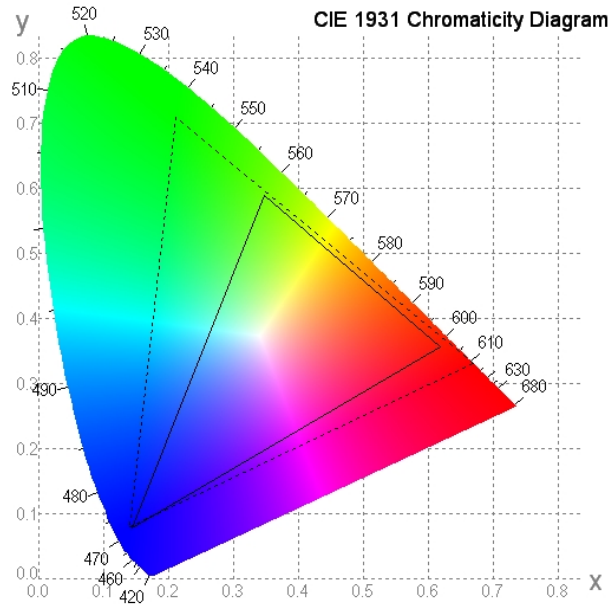

**7.6. Definition of Surface Luminance, Uniformity and Transmittance**

Using the transmissive mode measurement approach, measure the white screen luminance of the display panel and backlight.

7.6.1. Surface Luminance:  $L_v = \text{average}(L_{P1}:L_{P9})$

7.6.2. Uniformity =  $\text{Minimal}(L_{P1}:L_{P9}) / \text{Maximal}(L_{P1}:L_{P9}) * 100\%$

7.6.3. Transmittance =  $L_v \text{ on LCD} / L_v \text{ on Backlight} * 100\%$

Note: Measuring machine: BM-7

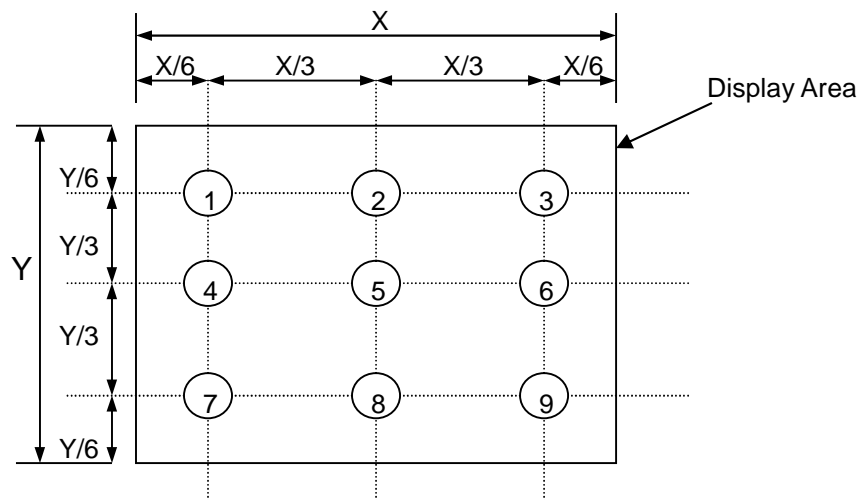

8. Block Diagram and Power Supply

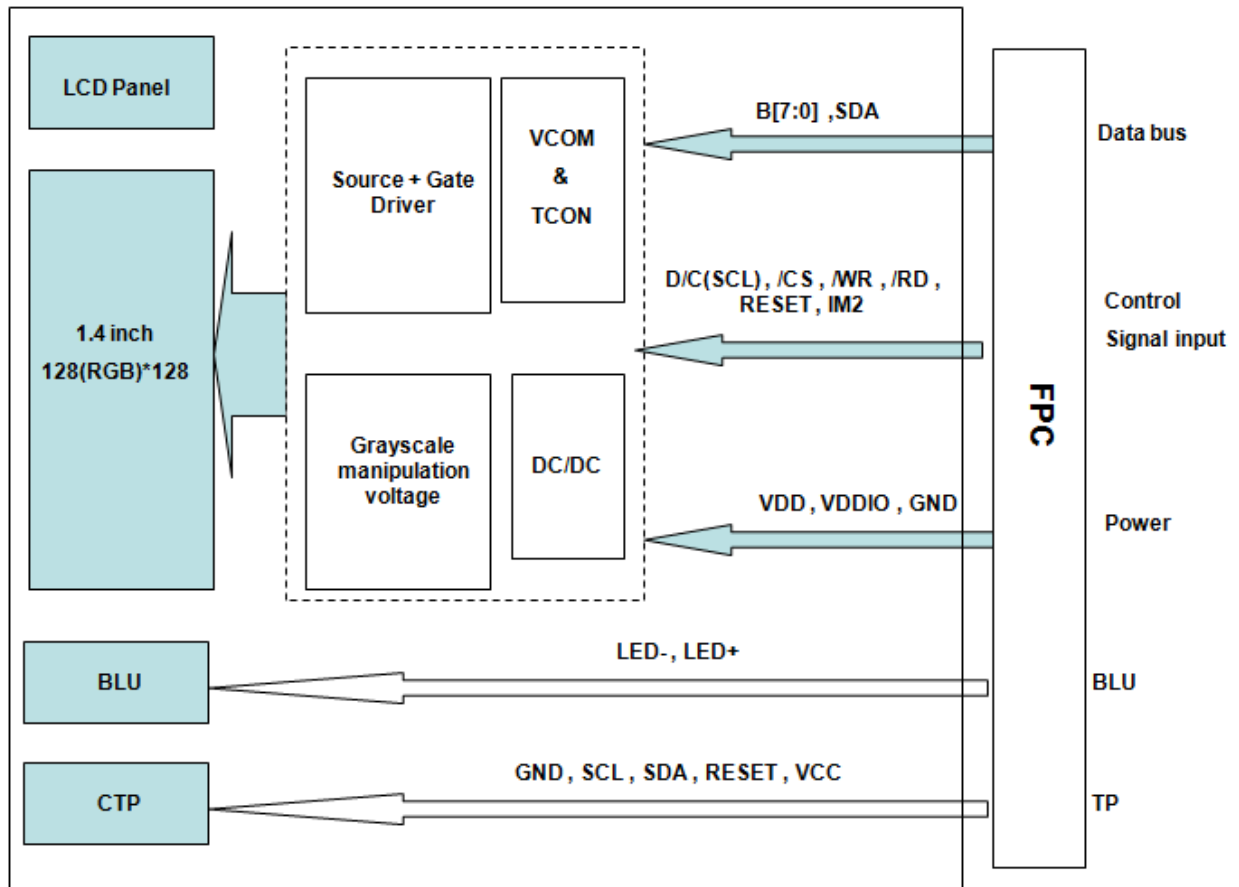

## 9. Interface Pins Definition

### 9.1 TFT PIN:

No.	Symbol	Function	Remark
1	GND	Ground	
2	LED-	LED power cathode	
3	LED+	LED power anode	
4	VDDIO	Logic power	
5	VDD	Analog Power	
6	D/C(SCL)	Data /Command select; In Serial Interface, this is used as SCL.	
7	/CS	Chip select input pin	
8	/WR	Write execution control pin	
9	/RD	Read execution control pin	
10	GND	Ground	
11	D7	Data bus	
12	D6	Data bus	
13	D5	Data bus	
14	D4	Data bus	
15	D3	Data bus	
16	D2	Data bus	
17	D1	Data bus	
18	D0(SDA)	Data bus; D0 is the serial input/output signal in serial interface mode.	
19	GND	Ground	
20	RESET	Reset Signal	
21	GND	Ground	
22	IM2	MCU Parallel Interface Bus and Serial Interface select IM2='1', Parallel Interface IM2='0', Serial Interface	

### 9.2 CTP PIN:

No.	Symbol	Function	Remark
1	GND	Ground	
2	SCL	Clock	
3	SDA	Data	
4	INT	Interrupt	
5	RESET	Reset	
6	VCC	Power supply	

10. AC Characteristics

10.1.8080-series Parallel Interface

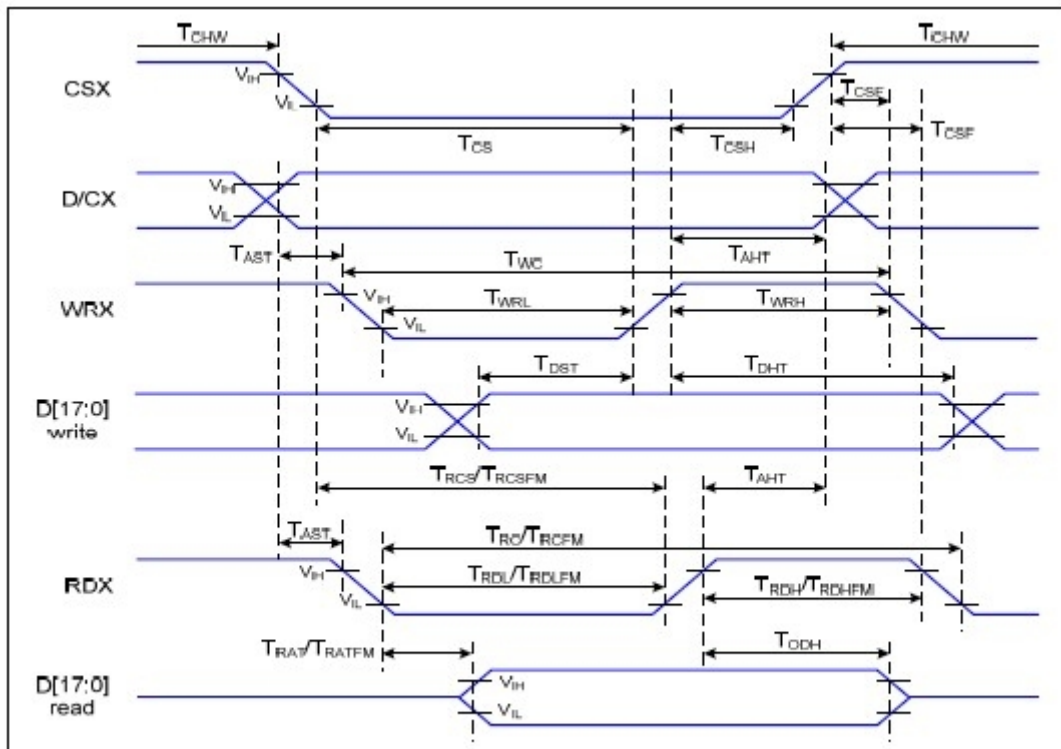

Figure 1 Parallel Interface Timing Characteristics (8080 Series MCU Interface)

Ta=25 °C, VDDI=1.65~3.7V, VDD=2.5~4.8V

Signal	Symbol	Parameter	Min	Max	Unit	Description
D/CX	TAST	Address Setup Time	0		ns	
	TAHT	Address Hold Time (Write/Read)	10		ns	
CSX	TCHW	Chip Select "H" Pulse Width	0		ns	
	TCS	Chip Select Setup Time (Write)	15		ns	
	TRCS	Chip Select Setup Time (Read ID)	45		ns	
	TRCSFM	Chip Select Setup time (Read FM)	355		ns	
	TCSF	Chip Select Wait Time (Write/Read)	10		ns	
	TCSH	Chip Select Hold Time	10		ns	
WRX	TWC	Write Cycle	66		ns	
	TWRH	Control Pulse "H" Duration	15		ns	
	TWRL	Control Pulse "L" Duration	15		ns	
RDX (ID)	TRC	Read Cycle (ID)	160		ns	When Read ID Data
	TRDH	Control Pulse "H" Duration (ID)	90		ns	
	TRDL	Control Pulse "L" Duration (ID)	45		ns	

RDX (FM)	TRCFM	Read Cycle (FM)	450		ns	When Read from Frame Memory
	TRDHF	Control Pulse "H" Duration (FM)	90		ns	
	TRDLF	Control Pulse "L" Duration (FM)	355		ns	
D[17:0]	TDST	Data Setup Time	10		ns	For CL=30pF
	TDHT	Data Hold Time	10		ns	
	TRAT	Read Access Time (ID)		40	ns	
	TRATFM	Read Access Time (FM)		340	ns	
	TODH	Output Disable Time	20	80	ns	

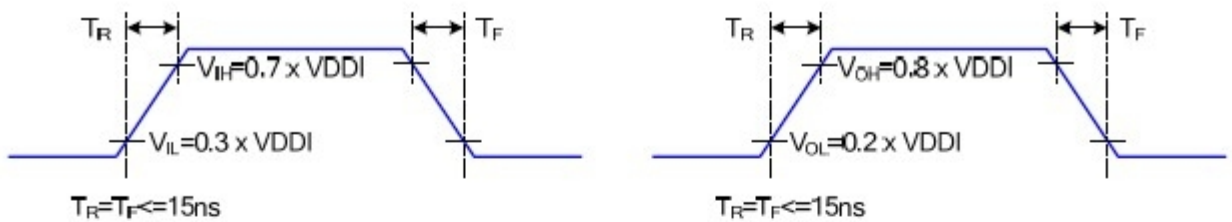

Figure 2 Rising And Falling Timing for Input And Output Signal

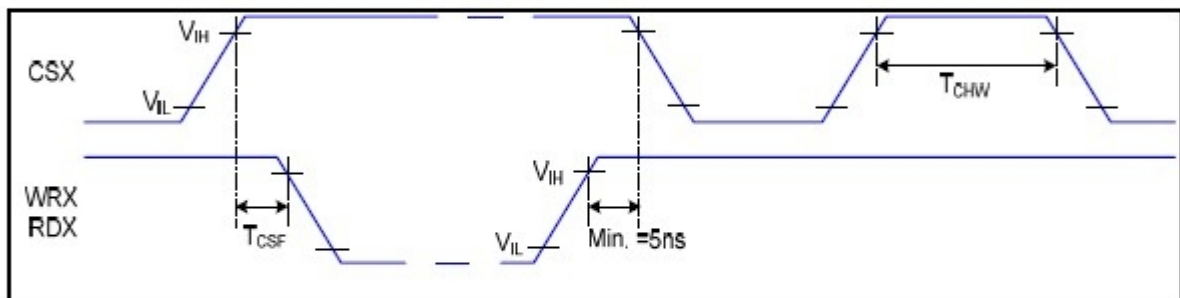

Figure 3 Chip Selection (CSX) Timing

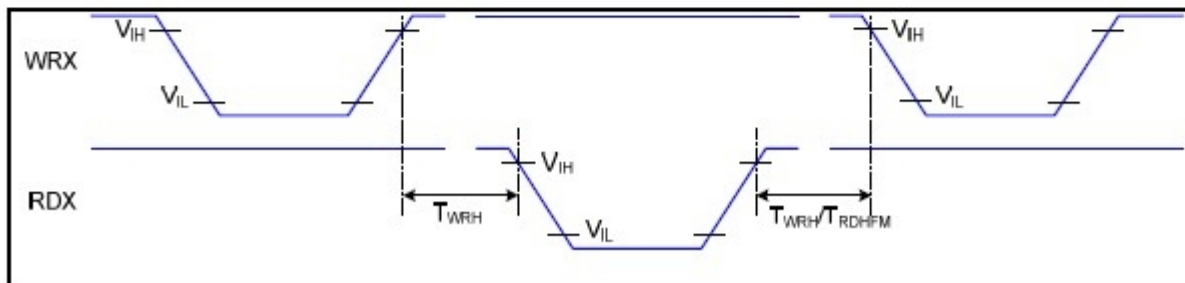

Figure 4 Write-to-Read And Read-to-Write Timing

10.2. Serial Interface Characteristics (3-line Serial)

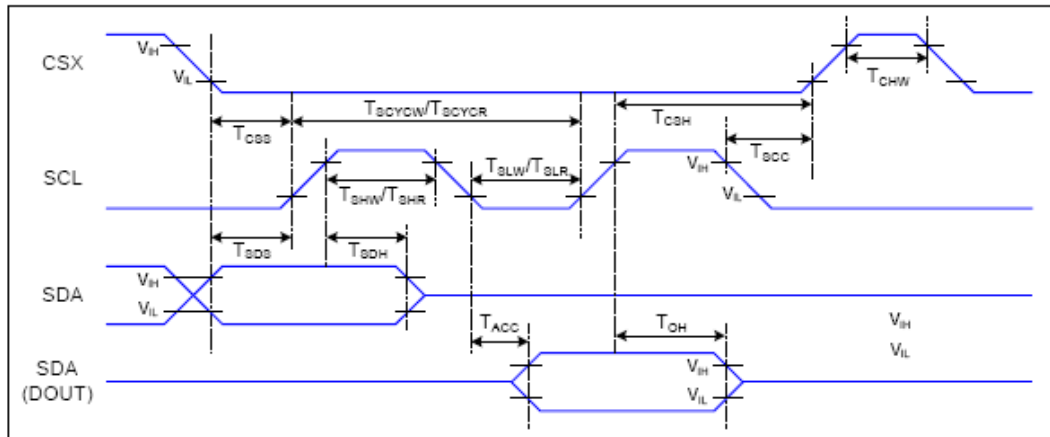

Figure 6 3-line Serial Interface Timing

$T_a=25\text{ }^\circ\text{C}$ ,  $V_{DDI}=1.65\sim 3.7\text{V}$ ,  $V_{DD}=2.5\sim 4.8\text{V}$

Signal	Symbol	Parameter	Min	Max	Unit	Description
CSX	TCSS	Chip Select Setup Time (Write)	15		ns	
	TCSH	Chip Select Hold Time (Write)	15		ns	
	TCSS	Chip Select Setup Time (Read)	60		ns	
	TSCC	Chip Select Hold Time (Read)	65		ns	
	TCHW	Chip Select "H" pulse width	40		ns	
SCL	TSCYCW	Serial Clock Cycle (Write)	66		ns	
	TSHW	SCL "H" Pulse Width (Write)	15		ns	
	TSLW	SCL "L" Pulse Width (Write)	15		ns	
	TSCYCR	Serial Clock Cycle (Read)	150		ns	
	TSHR	SCL "H" Pulse Width (Read)	60		ns	
	TSLR	SCL "L" Pulse Width (Read)	60		ns	
SDA (DIN) (DOUT)	TSDS	Data Setup Time	10		ns	For Maximum $C_L=30\text{pF}$ For Minimum $C_L=8\text{pF}$
	TSDH	Data Hold Time	10		ns	
	TACC	Access Time	10	50	ns	
	TOH	Output Disable Time	15	50	ns	

Table 6 3-line Serial Interface Characteristics

Note : The rising time and falling time ( $T_r$ ,  $T_f$ ) of input signal are specified at 15 ns or less. Logic high and low levels are specified as 30% and 70% of  $V_{DDI}$  for Input signals.

## **11. Quality Assurance**

### **11.1.Purpose**

This standard for Quality Assurance assures the quality of LCD module products supplied to customer.

### **11.2.Standard for Quality Test**

#### 11.2.1. Sampling Plan:

GB2828.1-2012

Single sampling, general inspection level II

#### 11.2.2. Sampling Criteria:

Visual inspection: AQL 1.5%

Electrical functional: AQL 0.65%.

#### 11.2.3. Reliability Test:

Detailed requirement refer to Reliability Test Specification.

### **11.3.Nonconforming Analysis & Disposition**

#### 11.3.1. Nonconforming analysis:

11.3.1.1. Customer should provide overall information of non-conforming sample for their complaints.

11.3.1.2. After receipt of detailed information from customer, the analysis of nonconforming parts usually should be finished in one week.

11.3.1.3. If cannot finish the analysis on time, customer will be notified with the progress status.

#### 11.3.2. Disposition of nonconforming:

11.3.2.1. Non-conforming product over PPM level will be replaced.

11.3.2.2. The cause of non-conformance will be analyzed. Corrective action will be discussed and implemented.

### **11.4.Agreement Items**

Shall negotiate with customer if the following situation occurs:

11.4.1. There is any discrepancy in standard of quality assurance.

11.4.2. Additional requirement to be added in product specification.

11.4.3. Any other special problem.

**11.5. Standard of the Product Visual Inspection**

11.5.1. Appearance inspection:

11.5.1.1. The inspection must be under illumination about 1000 – 1500 lx, and the distance of view must be at 30cm ± 2cm.

11.5.1.2. The viewing angle should be 45° from the vertical line without reflection light or follows customer's viewing angle specifications.

11.5.1.3. Definition of area: A Zone: Active Area, B Zone: Viewing Area,

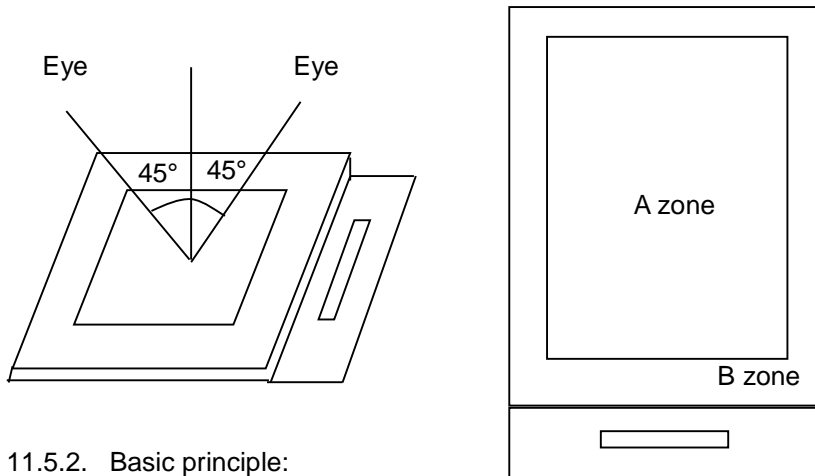

11.5.2. Basic principle:

11.5.2.1. A set of sample to indicate the limit of acceptable quality level must be discussed by both us and customer when there is any dispute happened.

11.5.2.2. New item must be added on time when it is necessary.

**11.6. Inspection Specification**

No.	Item	Criteria (Unit: mm)																			
01	Black / White spot Foreign material (Round type) Pinholes Stain Particles inside cell. (Minor defect)	<p><math>\phi = (a + b) / 2</math></p>	<table border="1"> <thead> <tr> <th>Size</th> <th>Area</th> <th>Acc. Qty</th> </tr> </thead> <tbody> <tr> <td><math>\phi \leq 0.10</math></td> <td></td> <td>Ignore</td> </tr> <tr> <td><math>0.10 &lt; \phi \leq 0.15</math></td> <td></td> <td>2</td> </tr> <tr> <td><math>0.15 &lt; \phi \leq 0.25</math></td> <td></td> <td>1</td> </tr> <tr> <td><math>0.25 &lt; \phi</math></td> <td></td> <td>0</td> </tr> <tr> <td>Total</td> <td></td> <td>2 no include <math>\phi \leq 0.10</math></td> </tr> </tbody> </table>	Size	Area	Acc. Qty	$\phi \leq 0.10$		Ignore	$0.10 < \phi \leq 0.15$		2	$0.15 < \phi \leq 0.25$		1	$0.25 < \phi$		0	Total		2 no include $\phi \leq 0.10$
			Size	Area	Acc. Qty																
$\phi \leq 0.10$		Ignore																			
$0.10 < \phi \leq 0.15$		2																			
$0.15 < \phi \leq 0.25$		1																			
$0.25 < \phi$		0																			
Total		2 no include $\phi \leq 0.10$																			
Distance between 2 defects should more than 3mm apart.																					

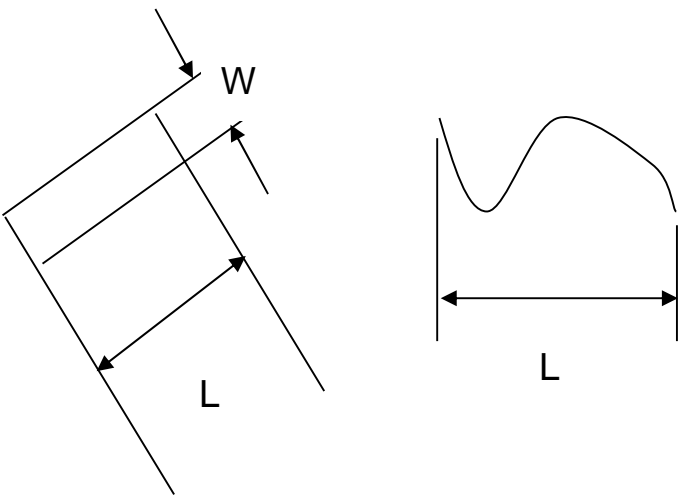
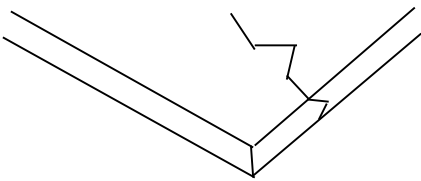

02	Electrical Defect (Minor defect)	<table border="1"> <thead> <tr> <th></th> <th>Display Area</th> <th>Total</th> <th></th> </tr> </thead> <tbody> <tr> <td>Bright dot</td> <td>0</td> <td>0</td> <td rowspan="3">Note1</td> </tr> <tr> <td>Dark dot</td> <td><math>N \leq 2</math></td> <td><math>N \leq 2</math></td> </tr> <tr> <td>Total dot</td> <td><math>N \leq 2</math></td> <td><math>N \leq 2</math></td> </tr> <tr> <td>Mura</td> <td colspan="2">Not visible through 5% ND filters.</td> <td>Note2</td> </tr> </tbody> </table> <p>Remark: 1. Bright dot caused by scratch and foreign object accords to item 1.</p>		Display Area	Total		Bright dot	0	0	Note1	Dark dot	$N \leq 2$	$N \leq 2$	Total dot	$N \leq 2$	$N \leq 2$	Mura	Not visible through 5% ND filters.		Note2
	Display Area	Total																		
Bright dot	0	0	Note1																	
Dark dot	$N \leq 2$	$N \leq 2$																		
Total dot	$N \leq 2$	$N \leq 2$																		
Mura	Not visible through 5% ND filters.		Note2																	
03	Black and White line Scratch Foreign material (Line type) (Minor defect)	 <table border="1"> <thead> <tr> <th>Length</th> <th>Width</th> <th>Acc. Qty</th> </tr> </thead> <tbody> <tr> <td>/</td> <td><math>W \leq 0.03</math></td> <td>Ignore</td> </tr> <tr> <td><math>L \leq 2.5</math></td> <td><math>0.03 &lt; W \leq 0.05</math></td> <td>3</td> </tr> <tr> <td><math>L \leq 2.5</math></td> <td><math>0.05 &lt; W \leq 0.10</math></td> <td>2</td> </tr> <tr> <td>/</td> <td><math>0.1 &lt; W</math></td> <td>0</td> </tr> <tr> <td colspan="2">Total</td> <td>3</td> </tr> </tbody> </table> <p>Distance between 2 defects should more than 3mm apart. Scratches not viewable through the back of the display are acceptable.</p>	Length	Width	Acc. Qty	/	$W \leq 0.03$	Ignore	$L \leq 2.5$	$0.03 < W \leq 0.05$	3	$L \leq 2.5$	$0.05 < W \leq 0.10$	2	/	$0.1 < W$	0	Total		3
Length	Width	Acc. Qty																		
/	$W \leq 0.03$	Ignore																		
$L \leq 2.5$	$0.03 < W \leq 0.05$	3																		
$L \leq 2.5$	$0.05 < W \leq 0.10$	2																		
/	$0.1 < W$	0																		
Total		3																		
04	Glass Crack (Minor defect)	 <p>Crack is potential to enlarge, any type is not allowed.</p>																		

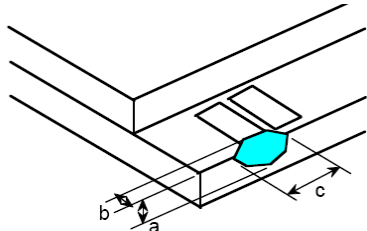
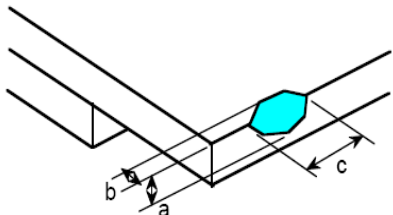
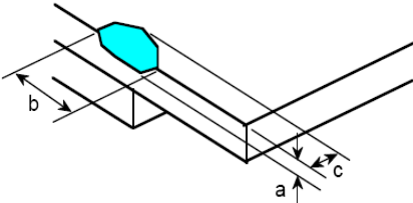
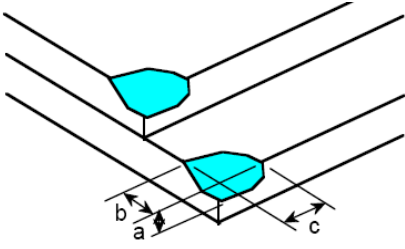
<p>05</p>	<p>Glass Chipping Pad Area: (Minor defect)</p> 	<table border="1"> <thead> <tr> <th>Length and Width</th> <th>Acc. Qty</th> </tr> </thead> <tbody> <tr> <td><math>c &gt; 3.0, b &lt; 1.0</math></td> <td>1</td> </tr> <tr> <td><math>c &lt; 3.0, b &lt; 1.0</math></td> <td>3</td> </tr> <tr> <td colspan="2"><math>a &lt; \text{Glass Thickness}</math></td> </tr> </tbody> </table>	Length and Width	Acc. Qty	$c > 3.0, b < 1.0$	1	$c < 3.0, b < 1.0$	3	$a < \text{Glass Thickness}$			
Length and Width	Acc. Qty											
$c > 3.0, b < 1.0$	1											
$c < 3.0, b < 1.0$	3											
$a < \text{Glass Thickness}$												
<p>06</p>	<p>Glass Chipping Rear of Pad Area: (Minor defect)</p> 	<table border="1"> <thead> <tr> <th>Length and Width</th> <th>Acc. Qty</th> </tr> </thead> <tbody> <tr> <td><math>c &gt; 3.0, b &lt; 1.0</math></td> <td>1</td> </tr> <tr> <td><math>c &lt; 3.0, b &lt; 1.0</math></td> <td>2</td> </tr> <tr> <td><math>c &lt; 3.0, b &lt; 0.5</math></td> <td>4</td> </tr> <tr> <td colspan="2"><math>a &lt; \text{Glass Thickness}</math></td> </tr> </tbody> </table>	Length and Width	Acc. Qty	$c > 3.0, b < 1.0$	1	$c < 3.0, b < 1.0$	2	$c < 3.0, b < 0.5$	4	$a < \text{Glass Thickness}$	
Length and Width	Acc. Qty											
$c > 3.0, b < 1.0$	1											
$c < 3.0, b < 1.0$	2											
$c < 3.0, b < 0.5$	4											
$a < \text{Glass Thickness}$												
<p>07</p>	<p>Glass Chipping Except Pad Area: (Minor defect)</p> 	<table border="1"> <thead> <tr> <th>Length and Width</th> <th>Acc. Qty</th> </tr> </thead> <tbody> <tr> <td><math>c &gt; 3.0, b &lt; 1.0</math></td> <td>1</td> </tr> <tr> <td><math>c &lt; 3.0, b &lt; 1.0</math></td> <td>2</td> </tr> <tr> <td><math>c &lt; 3.0, b &lt; 0.5</math></td> <td>4</td> </tr> <tr> <td colspan="2"><math>a &lt; \text{Glass Thickness}</math></td> </tr> </tbody> </table>	Length and Width	Acc. Qty	$c > 3.0, b < 1.0$	1	$c < 3.0, b < 1.0$	2	$c < 3.0, b < 0.5$	4	$a < \text{Glass Thickness}$	
Length and Width	Acc. Qty											
$c > 3.0, b < 1.0$	1											
$c < 3.0, b < 1.0$	2											
$c < 3.0, b < 0.5$	4											
$a < \text{Glass Thickness}$												
<p>08</p>	<p>Glass Corner Chipping: (Minor defect)</p> 	<table border="1"> <thead> <tr> <th>Length and Width</th> <th>Acc. Qty</th> </tr> </thead> <tbody> <tr> <td><math>c &lt; 3.0, b &lt; 3.0</math></td> <td>Ignore</td> </tr> <tr> <td colspan="2"><math>a &lt; \text{Glass Thickness}</math></td> </tr> </tbody> </table>	Length and Width	Acc. Qty	$c < 3.0, b < 3.0$	Ignore	$a < \text{Glass Thickness}$					
Length and Width	Acc. Qty											
$c < 3.0, b < 3.0$	Ignore											
$a < \text{Glass Thickness}$												

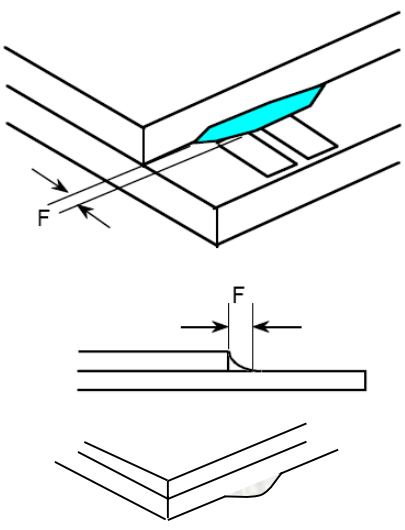
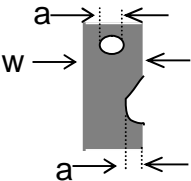
<p>09</p>	<p>Glass Burr: (Minor defect)</p> 	<table border="1" data-bbox="869 257 1340 347"> <thead> <tr> <th>Length</th> <th>Acc. Qty</th> </tr> </thead> <tbody> <tr> <td>F &lt; 1.0</td> <td>Ignore</td> </tr> </tbody> </table> <p>Glass burr don't affect assemble and module dimension.</p>	Length	Acc. Qty	F < 1.0	Ignore						
Length	Acc. Qty											
F < 1.0	Ignore											
<p>10</p>	<p>FPC Defect: (Minor defect)</p> 	<p>10.1 Dent, pinhole width <math>a &lt; w/3</math>. (w: circuitry width.) 10.2 Open circuit is unacceptable. 10.3 No oxidation, contamination and distortion.</p>										
<p>11</p>	<p>Bubble on Polarizer (Minor defect)</p>	<table border="1" data-bbox="742 1377 1212 1590"> <thead> <tr> <th>Diameter</th> <th>Acc. Qty</th> </tr> </thead> <tbody> <tr> <td><math>\varphi \leq 0.20</math></td> <td>Ignore</td> </tr> <tr> <td><math>0.20 &lt; \varphi \leq 0.30</math></td> <td>4</td> </tr> <tr> <td><math>0.30 &lt; \varphi \leq 0.50</math></td> <td>1</td> </tr> <tr> <td><math>0.50 &lt; \varphi</math></td> <td>None</td> </tr> </tbody> </table>	Diameter	Acc. Qty	$\varphi \leq 0.20$	Ignore	$0.20 < \varphi \leq 0.30$	4	$0.30 < \varphi \leq 0.50$	1	$0.50 < \varphi$	None
Diameter	Acc. Qty											
$\varphi \leq 0.20$	Ignore											
$0.20 < \varphi \leq 0.30$	4											
$0.30 < \varphi \leq 0.50$	1											
$0.50 < \varphi$	None											
<p>12</p>	<p>Dent on Polarizer (Minor defect)</p>	<table border="1" data-bbox="742 1646 1212 1859"> <thead> <tr> <th>Diameter</th> <th>Acc. Qty</th> </tr> </thead> <tbody> <tr> <td><math>\varphi \leq 0.20</math></td> <td>Ignore</td> </tr> <tr> <td><math>0.20 &lt; \varphi \leq 0.30</math></td> <td>4</td> </tr> <tr> <td><math>0.30 &lt; \varphi \leq 0.50</math></td> <td>1</td> </tr> <tr> <td><math>0.50 &lt; \varphi</math></td> <td>None</td> </tr> </tbody> </table>	Diameter	Acc. Qty	$\varphi \leq 0.20$	Ignore	$0.20 < \varphi \leq 0.30$	4	$0.30 < \varphi \leq 0.50$	1	$0.50 < \varphi$	None
Diameter	Acc. Qty											
$\varphi \leq 0.20$	Ignore											
$0.20 < \varphi \leq 0.30$	4											
$0.30 < \varphi \leq 0.50$	1											
$0.50 < \varphi$	None											
<p>13</p>	<p>Bezel</p>	<p>13.1 No rust, distortion on the Bezel. 13.2 No visible fingerprints, stains or other contamination.</p>										



14	Touch Panel	<p>D: Diameter W: width L: length</p> <p>14.1 Spot: <math>D &lt; 0.25</math> is acceptable  <math>0.25 \leq D \leq 0.4</math></p> <p>2dots are acceptable and the distance between defects should more than 10 mm.</p> <p><math>D &gt; 0.4</math> is unacceptable</p> <p>14.2 Dent: <math>D &gt; 0.40</math> is unacceptable</p> <p>14.3 Scratch: <math>W \leq 0.03</math>, <math>L \leq 10</math> is acceptable,  <math>0.03 &lt; W \leq 0.10</math>, <math>L \leq 10</math> is acceptable</p> <p>Distance between 2 defects should more than 10 mm.  <math>W &gt; 0.10</math> is unacceptable.</p>
15	PCB	<p>15.1 No distortion or contamination on PCB terminals.</p> <p>15.2 All components on PCB must same as documented on the BOM/component layout.</p> <p>15.3 Follow IPC-A-600F.</p>
16	Soldering	Follow IPC-A-610C standard
17	Electrical Defect (Major defect)	<p>The below defects must be rejected.</p> <p>17.1 Missing vertical / horizontal segment,</p> <p>17.2 Abnormal Display.</p> <p>17.3 No function or no display.</p> <p>17.4 Current exceeds product specifications.</p> <p>17.5 LCD viewing angle defect.</p> <p>17.6 No Backlight.</p> <p>17.7 Dark Backlight.</p> <p>17.8 Touch Panel no function.</p>

Remark: LCD Panel Broken shall be rejected. Defect out of LCD viewing area is acceptable.

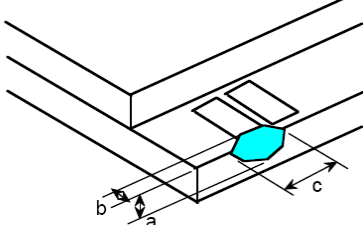
Inspection Specification for the Capacitive Touch Panel

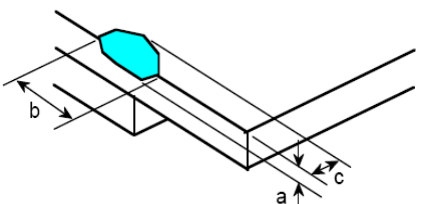
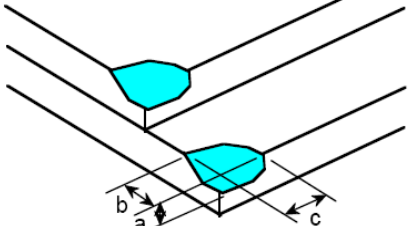
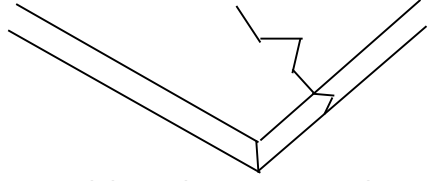
01	<p>Chipping Pad Area(Not include the cover lens): (Minor defect)</p> 	<p>The chip is seriously influence the product's function, any type is not allowed.</p>
----	--	---

<p>02</p>	<p>Chipping Except Pad Area(Not include the cover lens): (Minor defect)</p> 	<table border="1"> <thead> <tr> <th>Length and Width</th> <th>Acc. Qty</th> </tr> </thead> <tbody> <tr> <td><math>c &lt; 1.5, b &lt; 1</math></td> <td><math>N \leq 5</math></td> </tr> <tr> <td colspan="2"><math>a &lt; 1/2</math> Glass Thickness</td> </tr> </tbody> </table>	Length and Width	Acc. Qty	$c < 1.5, b < 1$	$N \leq 5$	$a < 1/2$ Glass Thickness	
Length and Width	Acc. Qty							
$c < 1.5, b < 1$	$N \leq 5$							
$a < 1/2$ Glass Thickness								
<p>03</p>	<p>Corner Chipping(Not include the cover lens): (Minor defect)</p> 	<table border="1"> <thead> <tr> <th>Length and Width</th> <th>Acc. Qty</th> </tr> </thead> <tbody> <tr> <td><math>c &lt; 1.5, b &lt; 0.5</math></td> <td>Ignore</td> </tr> <tr> <td colspan="2"><math>a &lt; 1/2</math> Glass Thickness</td> </tr> </tbody> </table>	Length and Width	Acc. Qty	$c < 1.5, b < 0.5$	Ignore	$a < 1/2$ Glass Thickness	
Length and Width	Acc. Qty							
$c < 1.5, b < 0.5$	Ignore							
$a < 1/2$ Glass Thickness								
<p>04</p>	<p>Crack: (Minor defect)</p>	 <p>Crack is potential to enlarge, any type is not allowed.</p>						
<p>05</p>	<p>Cover lens must be without any chips, cracks or other damage when viewed from the front.</p>							

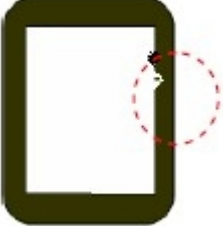
<p>06</p>	<p>Same/Different color spot</p> 	<p>D: Diameter W: width L: length</p> <table border="1" data-bbox="890 230 1343 362"> <thead> <tr> <th>Diameter</th> <th>Acc. Qty</th> </tr> </thead> <tbody> <tr> <td>D &lt; 0.20</td> <td>Ignore</td> </tr> </tbody> </table> <p>Active Area:</p> <table border="1" data-bbox="890 412 1343 631"> <thead> <tr> <th>Diameter</th> <th>Acc. Qty</th> </tr> </thead> <tbody> <tr> <td>0.20 &lt; D ≤ 0.30</td> <td>2</td> </tr> <tr> <td>0.30 &lt; D ≤ 0.50</td> <td>1</td> </tr> <tr> <td>D &gt; 0.5</td> <td>NG</td> </tr> </tbody> </table> <p>Viewing Area :</p> <table border="1" data-bbox="890 680 1343 913"> <thead> <tr> <th>Diameter</th> <th>Acc. Qty</th> </tr> </thead> <tbody> <tr> <td>D &lt; 0.20</td> <td>Ignore</td> </tr> <tr> <td>0.20 &lt; D ≤ 0.5</td> <td>3</td> </tr> <tr> <td>D &gt; 0.5</td> <td>NG</td> </tr> </tbody> </table> <p>Distance between 2 defects should more than 15mm apart.</p>	Diameter	Acc. Qty	D < 0.20	Ignore	Diameter	Acc. Qty	0.20 < D ≤ 0.30	2	0.30 < D ≤ 0.50	1	D > 0.5	NG	Diameter	Acc. Qty	D < 0.20	Ignore	0.20 < D ≤ 0.5	3	D > 0.5	NG
Diameter	Acc. Qty																					
D < 0.20	Ignore																					
Diameter	Acc. Qty																					
0.20 < D ≤ 0.30	2																					
0.30 < D ≤ 0.50	1																					
D > 0.5	NG																					
Diameter	Acc. Qty																					
D < 0.20	Ignore																					
0.20 < D ≤ 0.5	3																					
D > 0.5	NG																					
<p>07</p>	<p>Cover lens line Scratch</p> 	<table border="1" data-bbox="794 1124 1420 1429"> <thead> <tr> <th>Length</th> <th>Width</th> <th>Acc. Qty</th> </tr> </thead> <tbody> <tr> <td>/</td> <td>W ≤ 0.08mm</td> <td>Ignore</td> </tr> <tr> <td>L ≤ 5</td> <td>0.08 &lt; W ≤ 0.15</td> <td>2</td> </tr> <tr> <td>L ≤ 3</td> <td>0.15 &lt; W ≤ 0.20</td> <td>1</td> </tr> <tr> <td>-</td> <td>W &gt; 0.2</td> <td>NG</td> </tr> <tr> <td>L &gt; 5</td> <td>-</td> <td>NG</td> </tr> </tbody> </table> <p>Distance between 2 defects should more than 15mm apart.</p>	Length	Width	Acc. Qty	/	W ≤ 0.08mm	Ignore	L ≤ 5	0.08 < W ≤ 0.15	2	L ≤ 3	0.15 < W ≤ 0.20	1	-	W > 0.2	NG	L > 5	-	NG		
Length	Width	Acc. Qty																				
/	W ≤ 0.08mm	Ignore																				
L ≤ 5	0.08 < W ≤ 0.15	2																				
L ≤ 3	0.15 < W ≤ 0.20	1																				
-	W > 0.2	NG																				
L > 5	-	NG																				
<p>08</p>	<p>Printing sawtooth</p> 	<table border="1" data-bbox="794 1639 1420 1854"> <thead> <tr> <th>Length</th> <th>Width</th> <th>Acc. Qty</th> </tr> </thead> <tbody> <tr> <td>/</td> <td>W ≤ 0.2mm</td> <td>2</td> </tr> <tr> <td>L ≤ 2</td> <td>0.2 &lt; W ≤ 0.3</td> <td>1</td> </tr> <tr> <td>L ≤ 2</td> <td>W &gt; 0.3</td> <td>NG</td> </tr> </tbody> </table>	Length	Width	Acc. Qty	/	W ≤ 0.2mm	2	L ≤ 2	0.2 < W ≤ 0.3	1	L ≤ 2	W > 0.3	NG								
Length	Width	Acc. Qty																				
/	W ≤ 0.2mm	2																				
L ≤ 2	0.2 < W ≤ 0.3	1																				
L ≤ 2	W > 0.3	NG																				

**11.7. Classification of Defects**

- 11.7.1. Visual defects (Except no / wrong label) are treated as minor defect and electrical defect is major.
- 11.7.2. Two minor defects are equal to one major in lot sampling inspection.

**11.8. Identification/marketing criteria**

Any unit with illegible / wrong /double or no marking/ label shall be rejected.

**11.9. Packing**

- 11.9.1. There should be no damage of the outside carton box, each packaging box should have one identical label.
- 11.9.2. Modules inside package box should have compliant mark.
- 11.9.3. All direct package materials shall offer ESD protection.

**Note1:** Bright dot is defined as the defective area of the dot is larger than 50% of one sub-pixel area.

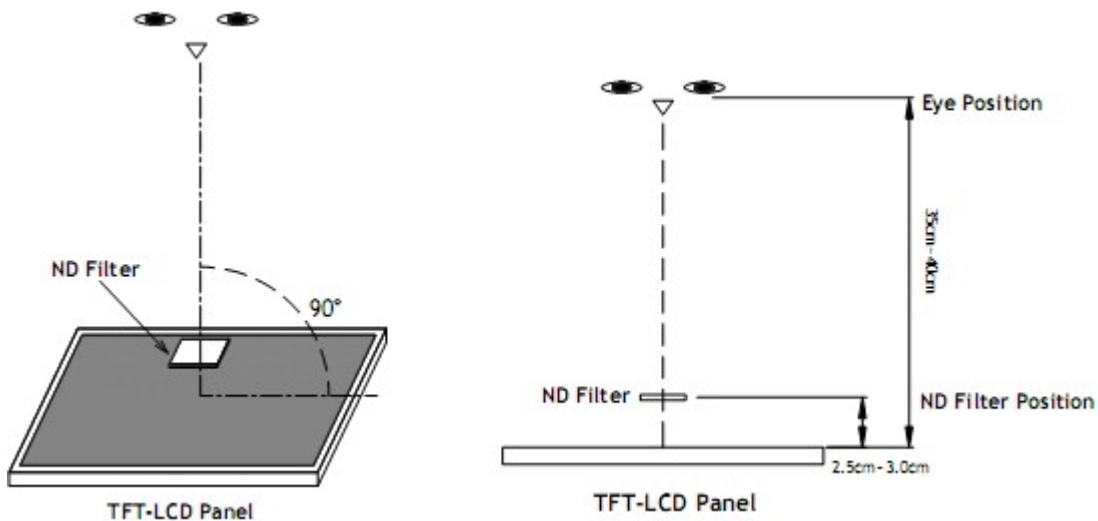

Bright dot: The bright dot size defect at black display pattern. It can be recognized by 2% transparency of filter when the distance between eyes and panel is 350mm ± 50mm.

Dark dot: Cyan, Magenta or Yellow dot size defect at white display pattern. It can be recognized by 5% transparency of filter when the distance between eyes and panel is 350mm ± 50mm.

**Note2:** Mura on display which appears darker / brighter against background brightness on parts of display area.

**12. Reliability Specification**

No	Item	Condition	Quantity	Criteria
1	High Temperature Operating	70°C, 96Hrs	2	GB/T2423.2-2008
2	Low Temperature Operating	-20°C, 96Hrs	2	GB/T2423.1-2008
3	High Humidity	50°C, 90%RH, 96Hrs	2	GB/T2423.3-2006
4	High Temperature Storage	80°C, 96Hrs	2	GB/T2423.2-2008
5	Low Temperature Storage	-30°C, 96Hrs	2	GB/T2423.1-2008
6	Thermal Cycling Test	-20°C, 60min~70°C, 60min, 20 cycles.	2	GB/T2423.22-2012
7	Packing Vibration	Frequency range:10Hz~50Hz Acceleration of gravity:5G X, Y, Z 30 min for each direction.	2	GB/T5170.14-2009
8	Electrical Static Discharge	Air: ± 8kV 150pF/330 Ω 5 times Contact: ± 4kV 150pF/330 Ω 5 times	2	GB/T17626.2-2006
9	Drop Test (Packaged)	Height:80 cm,1 corner, 3 edges, 6 surfaces.	2	GB/T2423.8-1995

Note1. No deflection cosmetic and operational function allowable.

Note2. Total current Consumption should be below double of initial value

**13. Precautions and Warranty****13.1.Safety**

- 13.1.1. The liquid crystal in the LCD is poisonous. Do not put it in your mouth. If the liquid crystal touches your skin or clothes, wash it off immediately using soap and water.
- 13.1.2. Since the liquid crystal cells are made of glass, do not apply strong impact on them. Handle with care.

**13.2.Handling**

- 13.2.1. Reverse and use within ratings in order to keep performance and prevent damage.
- 13.2.2. Do not wipe the polarizer with dry cloth, as it might cause scratch. If the surface of the LCD needs to be cleaned, wipe it swiftly with cotton or other soft cloth soaked with petroleum IPA, do not use other chemicals.



**14. Precautions and Warranty**

**14.1. Safety**

- 14.1.1. The liquid crystal in the LCD is poisonous. Do not put it in your mouth. If the liquid crystal touches your skin or clothes, wash it off immediately using soap and water.
- 14.1.2. Since the liquid crystal cells are made of glass, do not apply strong impact on them. Handle with care.

**14.2. Handling**

- 14.2.1. Reverse and use within ratings in order to keep performance and prevent damage.
- 14.2.2. Do not wipe the polarizer with dry cloth, as it might cause scratch. If the surface of the LCD needs to be cleaned, wipe it swiftly with cotton or other soft cloth soaked with petroleum IPA, do not use other chemicals.

**14.3. Storage**

- 14.3.1. Do not store the LCD module beyond the specified temperature ranges.
- 14.3.2. Strong light exposure causes degradation of polarizer and color filter.

**14.4. Metal Pin (Apply to Products with Metal Pins)**

14.4.1. Pins of LCD and Backlight

14.4.1.1. Solder tip can touch and press on the tip of Pin LEAD during the soldering

14.4.1.2. Recommended Soldering Conditions

Solder Type: Sn96.3~94-Ag3.3~4.3-Cu0.4~1.1

Maximum Solder Temperature: 370°C

Maximum Solder Time: 3s at the maximum temperature

Recommended Soldering Temp: 350±20°C

Typical Soldering Time: ≤3s

14.4.1.3. Solder Wetting

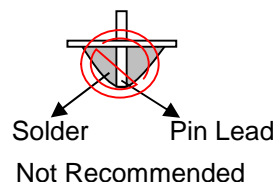
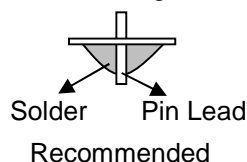

14.4.2. Pins of EL

14.4.2.1. Solder tip can touch and press on the tip of EL leads during soldering.

14.4.2.2. No Solder Paste on the soldering pad on the motherboard is recommended.

14.4.2.3. Recommended Soldering Conditions

Solder type: Nippon Alimit Leadfree SR-34, size 0.5mm

Recommended Solder Temperature: 270~290°C

Typical Soldering Time: ≤2s

Minimum solder distance from EL lamp (body):2.0mm

14.4.2.4. No horizontal press on the EL leads during soldering.

14.4.2.5. 180° bend EL leads three times is not allowed.

14.4.2.6. Solder Wetting

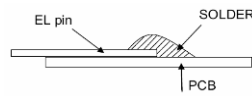

Recommended

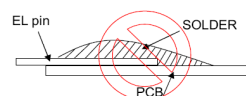

Not Recommended

14.4.2.7. The type of the solder iron:

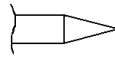

Recommended

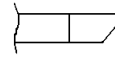

Not Recommended

14.4.2.8. Solder Pad

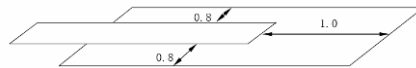

**14.5.Operation**

- 14.5.1. Do not drive LCD with DC voltage
- 14.5.2. Response time will increase below lower temperature
- 14.5.3. Display may change color with different temperature
- 14.5.4. Mechanical disturbance during operation, such as pressing on the display area, may cause the segments to appear “fractured”.
- 14.5.5. Do not connect or disconnect the LCM to or from the system when power is on.
- 14.5.6. Never use the LCM under abnormal condition of high temperature and high humidity.
- 14.5.7. Module has high frequency circuits. Sufficient suppression to the electromagnetic interface shall be done by system manufacturers. Grounding and shielding methods may be important to minimize the interference.
- 14.5.8. Do not display the fixed pattern for long time (we suggest the time not longer than one hour) because it may develop image sticking due to the TFT structure.

**14.6.Static Electricity**

- 14.6.1. CMOS LSIs are equipped in this unit, so care must be taken to avoid the electro-static charge, by ground human body, etc.
- 14.6.2. The normal static prevention measures should be observed for work clothes and benches.
- 14.6.3. The module should be kept into anti-static bags or other containers resistant to static for storage.

**14.7.Limited Warranty**

- 14.7.1. Our warranty liability is limited to repair and/or replacement. We will not be responsible for any consequential loss.
- 14.7.2. If possible, we suggest customer to use up all modules in six months. If the module storage time over twelve months, we suggest that recheck it before the module be used.
- 14.7.3. After the product shipped, any product quality issues must be feedback within three months, otherwise, we will not be responsible for the subsequent or consequential events.

15. Outline Drawing

