

**DISPLAY Elektronik GmbH**

# DATA SHEET

**LCD MODULE**

## **DEM 128064T FGH-PW**

**Product Specification**

**Version: 1**

**22.02.2013**

# GENERAL SPECIFICATION

---

MODULE NO. :

## DEM 128064T FGH-PW

VERSION NO.	CHANGE DESCRIPTION	DATE
0	ORIGINAL VERSION	07.02.2013
1	CHANGE OPTICAL CHARACTERISTICS	22.02.2013

PREPARED BY: AH

DATE: 22.04.2013

APPROVED BY: MH

DATE: 22.04.2013

## **CONTENTS**

1. LCD DRAWING	-----	4
2. PRODUCT SPECIFICATIONS	-----	5
2.1 General	-----	5
2.2 Mechanical Characteristics	-----	5
2.3 Absolute Maximum Ratings	-----	6
2.4 Electrical Characteristics	-----	6
2.5 Optical Characteristics Absolute maximum ratings	-----	6
2.6 Optical Characteristics	-----	7
2.7 LED Back-light Characteristics	-----	8
3. RELIABILITY	-----	9
4. OPERATING INSTRUCTIONS	-----	10
4.1 Input signal Function	-----	10
4.2 Voltage Generator Circuit	-----	12
4.3 Timing Diagram	-----	13
5. NOTES	-----	15
6. OPERATION PRECAUTIONS	-----	15

1. LCD DRAWING

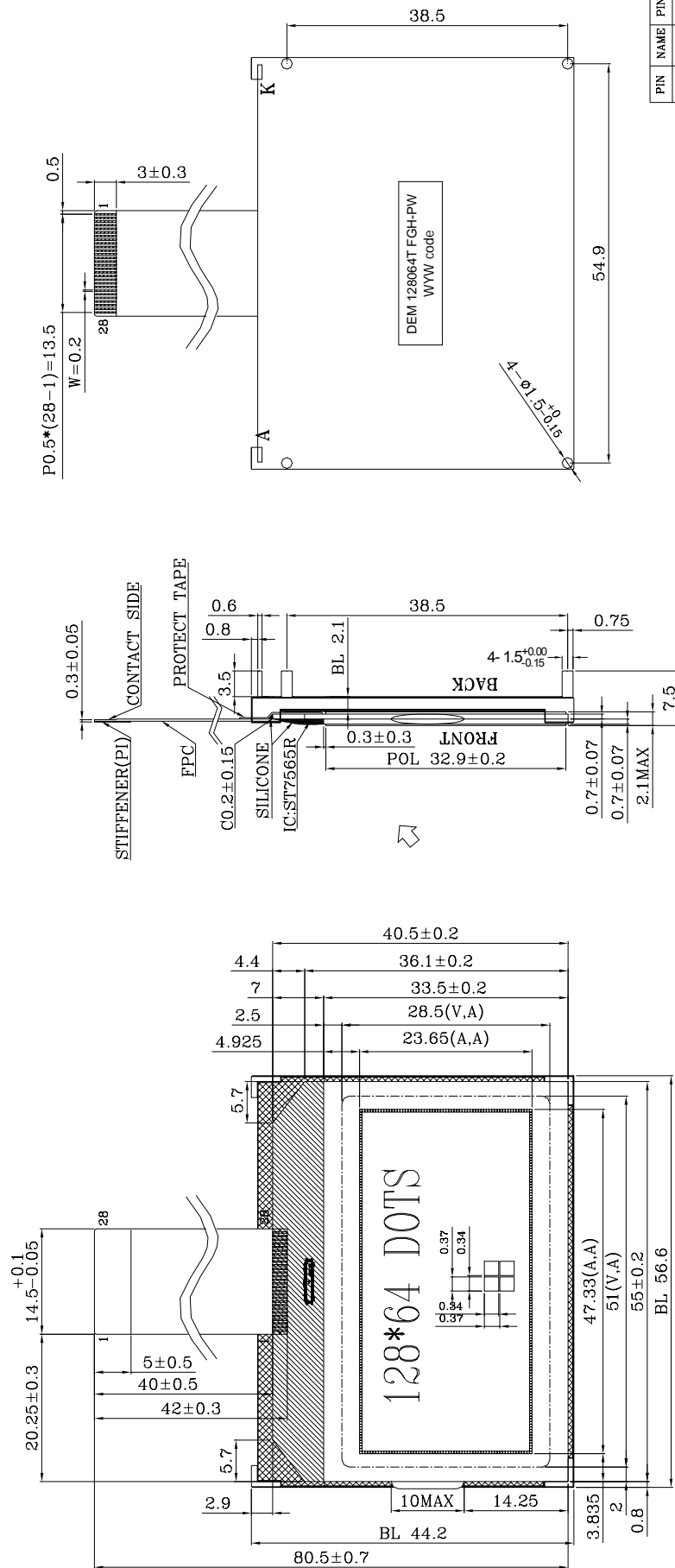

PIN	NAME	PIN	NAME
1	CSIB	15	VSS
2	RST	16	VOUT
3	A0	17	CAP3+
4	/WR	18	CAP1-
5	/RD	19	CAP1+
6	D0	20	CAP2+
7	D1	21	CAP2-
8	D2	22	CAP4+
9	D3	23	V4
10	D4	24	V3
11	D5	25	V2
12	D6	26	V1
13	D7	27	V0
14	VDD	28	PSB

- NOTES:
1. DRIVE METHOD: 1/64DUTY, 1/9BIAS, V<sub>lcd</sub> 8.5V.
  2. VIEWING ANGLE: 6 0'CLOCK.
  3. DISPLAY TYPE: FSTN, TRANSPARENT/POSITIVE.
  4. OPERATING TEMP: -20 TO 70°C.
  5. STORAGE TEMP: -30 TO 80°C.
  6. CONNECTION: COG+FPC. 小片在上
  7. IC: ST7565R.
  8. BACKLIGHT: WHITE, 3.IV, 60mA, 950cd/m<sup>2</sup>
  9. NOT DIMENSION TOLERANCES IS ±0.3.

## 2. PRODUCT SPECIFICATIONS

### 2.1 General

- 128 × 64 Dot Matrix LCD
- FSTN, Positive Mode
- Transflective , Wide Temperature Type
- 6 o'clock
- Multiplexing Driving : 1/64duty, 1/9bias
- Controller IC ST7565R (Sitronix)
- Backlight : Edge LED, White

### 2.2 Mechanical Characteristics

Item	Characteristic
Dot Configuration	128 x 64
Dot Dimensions(mm)	0.34 x 0.34
Dot Spacing (mm)	0.37 x 0.37
Module Dimensions (Horizontal × Vertical × Thickness, mm)	56.60 x 44.20 x 7.50
Viewing Area (Horizontal × Vertical, mm)	51.00 x 28.50
Active Area (Horizontal × Vertical, mm)	47.33 x 23.65
Backlight Outline Dimension	56.60 x 44.20 x 3.60

### 2.3 Absolute Maximum Ratings (without LED Backlight)

Characteristic	Symbol	Unit	Value
Operating Voltage (logic)	$V_{DD}$	V	-0.3 to +5.0
Input Voltage	$V_{IN}$	V	-0.3 to $V_{DD}+0.3$

Note 1: Referenced to  $V_{SS}=0V$

### 2.4 Electrical Characteristics (without LED Backlight)

Characteristic	Symbol	Condition	Min.	Typ.	Max.	Unit
Operating Voltage(logic)	$V_{DD}-V_{SS}$	--	3.0	3.3	3.6	V
Input Voltage	$V_{IH}$	--	$0.8V_{DD}$	--	$V_{DD}$	V
	$V_{IL}$	--	$V_{SS}$	--	$0.2V_{DD}$	
Output Voltage	$V_{OH}$	$I_{OH}=-0.1mA$	$0.8V_{DD}$	--	$V_{DD}$	V
	$V_{HL}$	$I_{OL}=0.1mA$	$V_{SS}$	--	$0.2V_{DD}$	
Current Consumption	$I_{DD}$	$V_{IN}=V_{DD}$	--	0.05	1	mA

### 2.5 Optical Characteristics Absolute Maximum Ratings

Item	Symbol	Rating	Unit
Operating temperature range	Top	-20 ~ 70	°C
Storage temperature range	Tst	-30 ~ 80	°C

2.6 Optical Characteristics

1/64 duty, 1/9bias, Vlcd=8.5V, Ta=25°C

Item	Symbol	Conditions	Min.	Typ.	Max	Reference
Driving voltage	Vlcd=VDD-VO		8.2	8.5	8.8	V
	Vlcd	-20°C	8.5	8.8	9.1	V
		+25°C	8.2	8.5	8.8	V
		+70°C	7.9	8.2	8.5	V
Viewing angle	$\theta$	$C \geq 2.0, \phi = 0^\circ$	30°	-		Notes 1 & 2
Contrast	C	$\theta = 5^\circ, \phi = 0^\circ$	3.0	--	-	Note 3
Response time(rise)	ton	$\theta = 5^\circ, \phi = 0^\circ$	-		198ms	Note 4
Response time(fall)	toff	$\theta = 5^\circ, \phi = 0^\circ$	-	-	176ms	Note 4

Note 1: Definition of angles  $\theta$  and  $\phi$

Note 2: Definition of viewing angles  $\theta_1$  and  $\theta_2$

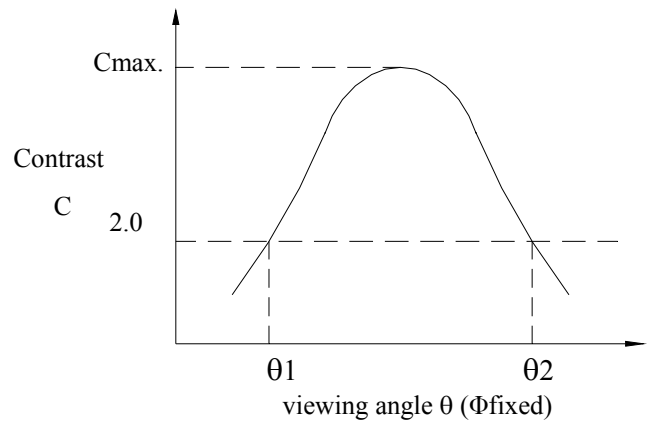
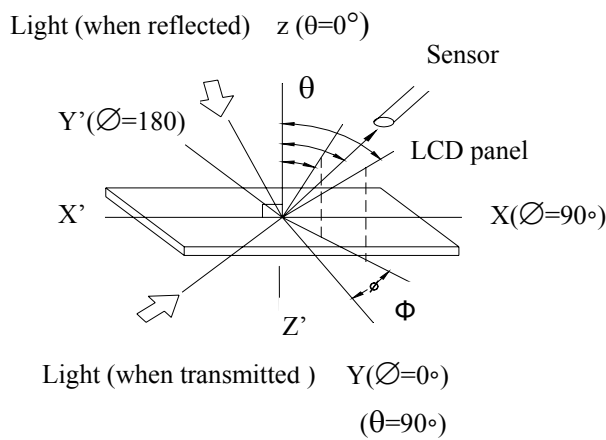

Note : Optimum viewing angle with the naked eye and viewing angle  $\theta$  at Cmax. Above are not always the same

Note 3: Definition of contrast C

$$C = \frac{\text{Brightness (reflection) of unselected dot (B2)}}{\text{Brightness (reflection) of selected dot (B1)}}$$

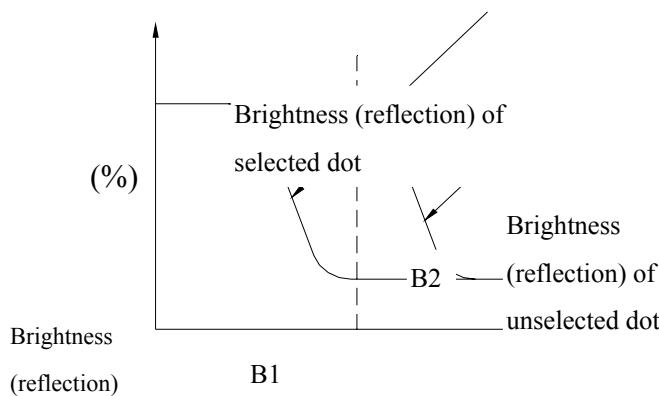

Note 4: Definition of response time

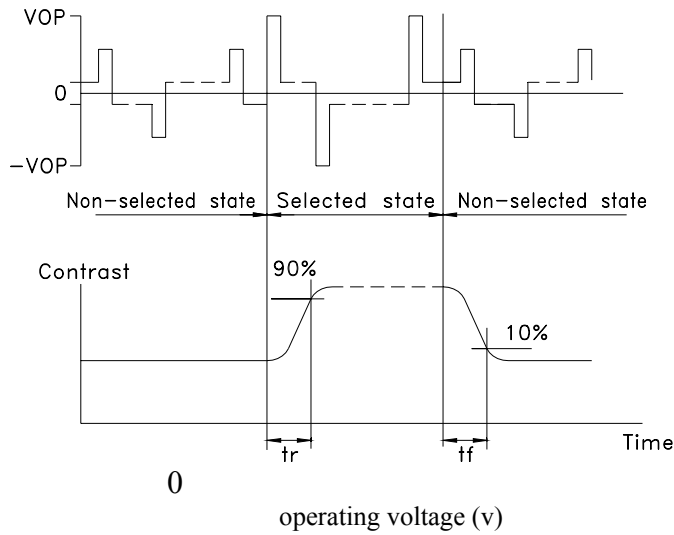

Note: Measured with a transmissive LCD panel which is displayed 1 cm<sup>2</sup>

- $V_{OPR}$  : Operating voltage
- $f_{FRM}$  : Frame frequency
- $t_{ON}$  : Response time (rise)
- $t_{OFF}$  : Response time (fall)



**2.7 LED Backlight Characteristics**

**2.7.1 Electrical / optical specifications**

Ta = 25°C

Item	Symbol	Condition	Min.	Typ.	Max.	Unit
Forward voltage	V <sub>f</sub>	If=60mA, White	2.9	3.1	3.4	V
LED *Luminous Intensity	I <sub>v</sub>	If=60mA, White	800	950	--	cd/m2
Chromaticity Coordinate	x	If=60mA, White	0.26	0.29	0.32	
	y		0.26	0.29	0.32	
Reverse Current	I <sub>R</sub>	VR=5V, White	--	--	0.1	mA

Note: \* Measured at the bare LED Backlight Unit.

**2.7.2 LED Maximum Operating Range**

Item	Symbol	White	Unit
Power Dissipation	P <sub>AD</sub>	272	mW
Forward Current	I <sub>F</sub>	80	mA
Reverse Voltage	V <sub>R</sub>	5	V

### 3. RELIABILITY

#### 3.1 Reliability

Test item	Test condition	Evaluation and assessment
Operation at high temperature and humidity	40 °C±2 °C 90%RH for 500hours	No abnormalities in functions* and appearance**
Operation at high temperature	60 °C±2 °C for 500 hours	No abnormalities in functions* and appearance**
Heat shock	-20± ~ +60 °C Left for 1 hour at each temperature, transition time 5 min, repeated 10times	No abnormalities in functions* and appearance**
Low temperature	-20±2 °C for 500 hours	No abnormalities in functions* and appearance**
Vibration	Sweep for 1 min at 10 Hz, 55Hz, 10Hz, amplitude 1.5mm 2 hrs each in the X,Y and Z directions	No abnormalities in functions* and appearance**
Drop shock	Dropped onto a board from a height of 10cm	No abnormalities in functions* and appearance**

\* Dissipation current, contrast and display functions

\*\* Polarizing filter deterioration, other appearance defects

#### 3.2 Liquid Crystal Panel Service Life

100,000 hours minimum at 25 °C±10 °C

#### 3.3 Definition of Panel Service Life

- Contrast becomes 30% of initial value
- Current consumption becomes three times higher than initial value
- Remarkable alignment deterioration occurs in LCD cell layer
- Unusual operation occurs in display functions

## 4. OPERATING INSTRUCTIONS

### 4.1 Input signal Function

Pin No	Symbol	I/O	Function
1	CS1B	I	This is the chip select signal. When CS1 = "L" and CS2 = "H," then the chip select becomes active, and data/command I/O is enabled.
2	RST	I	Reset Signal Input Pin (Low Active).
3	A0	I	This is connect to the least significant bit of the normal MPU address bus, and it determines whether the data bits are data or a command. A0 = "H": Indicates that D0 to D7 are display data. A0 = "L": Indicates that D0 to D7 are control data.
4	/WR	I	<ul style="list-style-type: none"> <li>When connected to an 8080 MPU, this is active LOW.</li> </ul> (R/W) This terminal connects to the 8080 MPU WR signal. The signals on the data bus are latched at the rising edge of the WR signal. <ul style="list-style-type: none"> <li>When connected to a 6800 Series MPU: This is the read/write control signal input terminal. When R/W = "H": Read. When R/W = "L": Write.</li> </ul>
5	/RD	I	<ul style="list-style-type: none"> <li>When connected to an 8080 MPU, this is active LOW.</li> </ul> (E) This pin is connected to the RD signal of the 8080 MPU, and the ST7565S series data bus is in an output status when this signal is "L". <ul style="list-style-type: none"> <li>When connected to a 6800 Series MPU, this is active HIGH. This is the 6800 Series MPU enable clock input terminal.</li> </ul>
6-13	D0- D7	I/O	This is an 8-bit bi-directional data bus that connects to an 8-bit or 16-bit standard MPU data bus. When the serial interface is selected (P/S = "L") : D0 to D5 are set to high impedance. D6 : the serial clock input (SCL) ; D7 : serial data input (SI) . When the chip select is not active, D0 to D7 are set to high impedance.
14	VDD	PWR	Shared with the MPU power supply terminal Vcc.
15	VSS	PWR	This is a 0V terminal connected to the system GND.
16	VOUT	PWR	DC/DC voltage converter. Connect a capacitor between this terminal and VSS.
17	CAP3+	PWR	DC/DC voltage converter. Connect a capacitor between this terminal and the CAP3+ terminal.
18	CAP1-	PWR	DC/DC voltage converter. Connect a capacitor between this terminal and the CAP1- terminal.
19	CAP1+	PWR	DC/DC voltage converter. Connect a capacitor between this terminal and the CAP1+ terminal.
20	CAP2+	PWR	DC/DC voltage converter. Connect a capacitor between this terminal and the CAP2+ terminal.

21	CAP2-	PWR	DC/DC voltage converter. Connect a capacitor between this terminal and the CAP2-terminal.															
22	CAP4+	PWR	DC/DC voltage converter. Connect a capacitor between this terminal and the CAP4+terminal.															
23-27	V4-V0	PWR	This is a multi-level power supply for the liquid crystal drive. The voltage Supply applied is determined by the liquid crystal cell, and is changed through the use of a resistive voltage divided or through changing the impedance using an op.amp. Voltage levels are determined based on VDD, and must maintain the relative magnitudes shown below. VDD (= V0) ≥ V1 ≥ V2 ≥ V3 ≥ V4															
28	PSB	I	<p>This is the parallel data input/serial data input switch terminal. PSB = H: Parallel data input PSB = L: Serial data input The following applies depending on the PSB(P/S) status:</p> <table border="1"> <thead> <tr> <th>P/S</th> <th>Data/Command</th> <th>Data</th> <th>Read/Write</th> <th>Serial Clock</th> </tr> </thead> <tbody> <tr> <td>"H"</td> <td>A0</td> <td>D0 to D7</td> <td>/RD, /WR</td> <td>X</td> </tr> <tr> <td>"L"</td> <td>A0</td> <td>SI (D7)</td> <td>Write only</td> <td>SCL (D6)</td> </tr> </tbody> </table> <p>When PSB = L, D0 to D5 fixed to H. /RD (E) and /WR (R/W) are fixed to either H or L. With serial data input, It is impossible read data from RAM.</p>	P/S	Data/Command	Data	Read/Write	Serial Clock	"H"	A0	D0 to D7	/RD, /WR	X	"L"	A0	SI (D7)	Write only	SCL (D6)
P/S	Data/Command	Data	Read/Write	Serial Clock														
"H"	A0	D0 to D7	/RD, /WR	X														
"L"	A0	SI (D7)	Write only	SCL (D6)														

**Table 1**

P/S	/CS1	CS2	A0	/RD	/WR	C86	D7	D6	D5~D0
H: Parallel Input	/CS1	CS2	A0	/RD	/WR	C86	D7	D6	D5~D0
L: Serial Input	/CS1	CS2	A0	—	—	—	SI	SCL	(HZ)

“—” indicates fixed to either “H” or to “L”

4.2 Voltage Generator Circuit

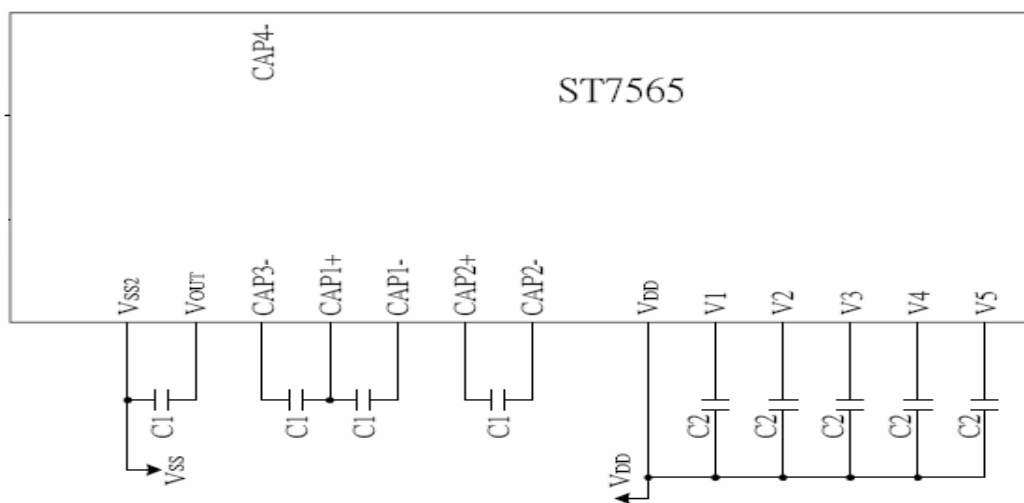
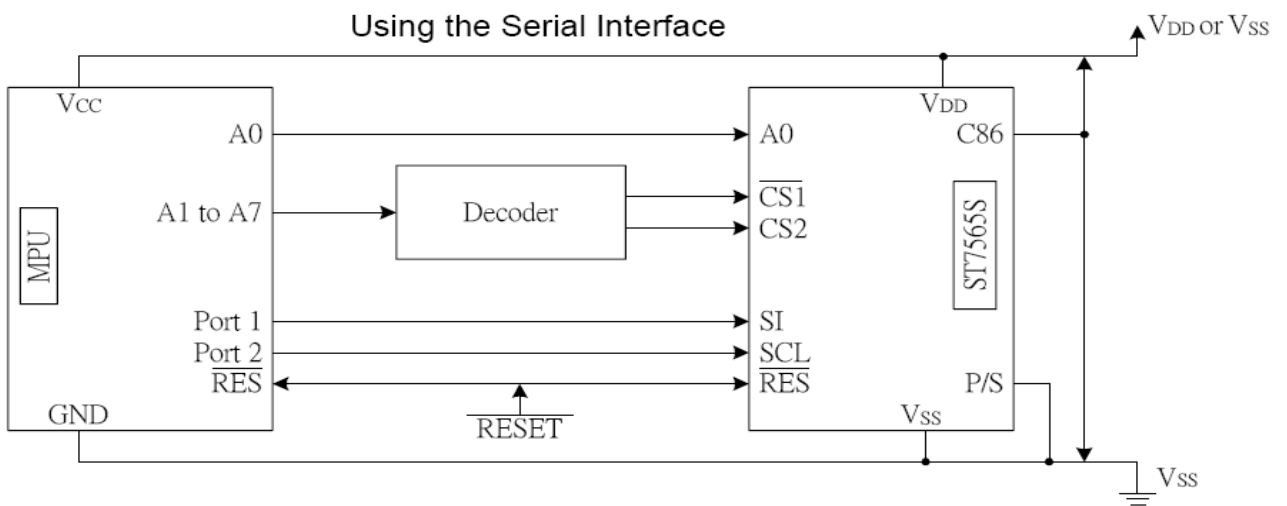
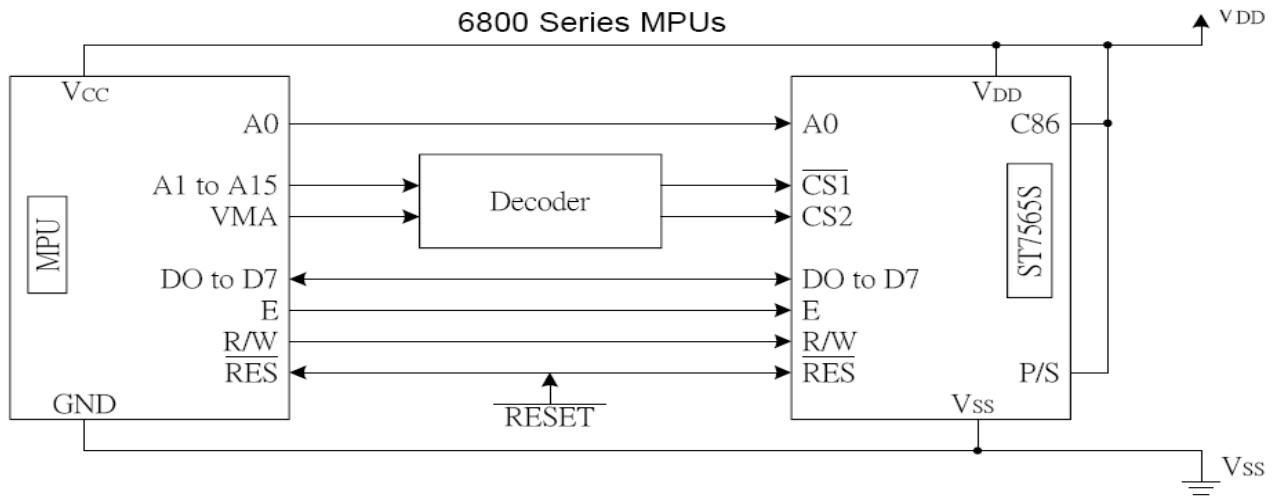

Item	Set value	units
c1	1.0 to 4.7	uF
c2	0.1 to 4.7	uF

4.3 Timing Diagram

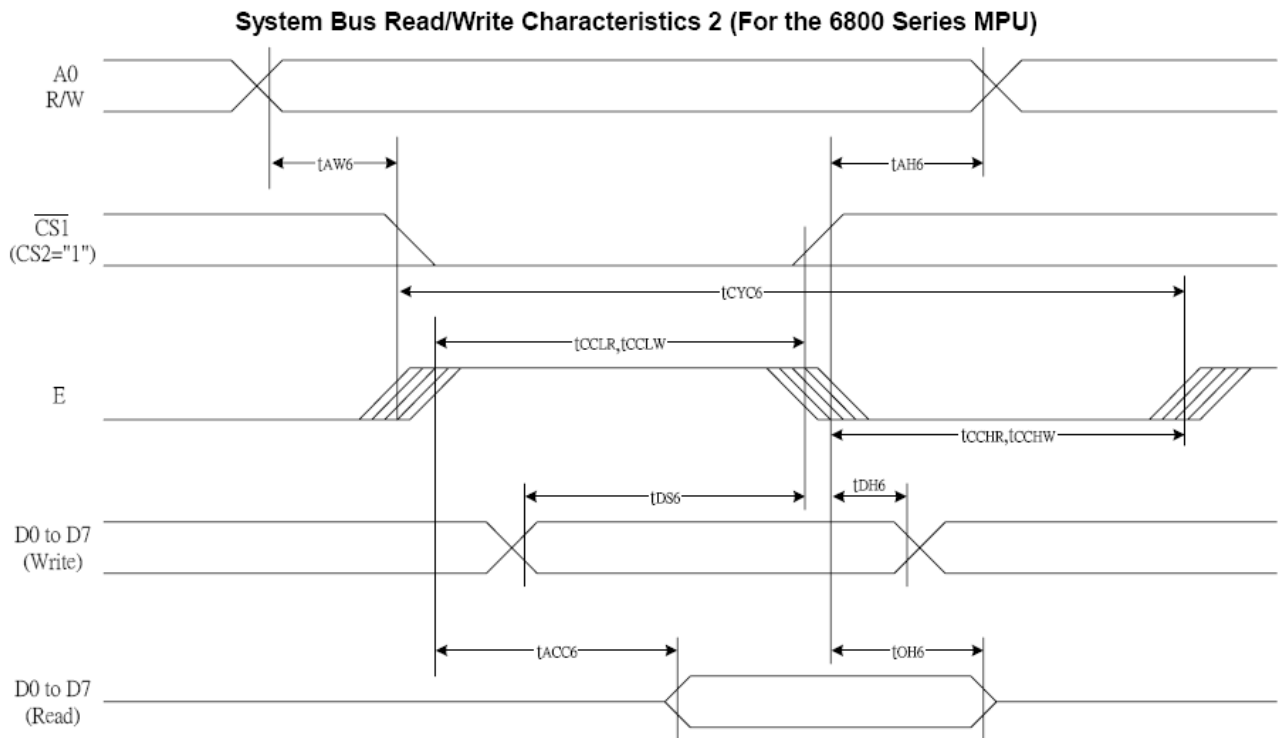

Item	Signal	Symbol	Condition	Rating		Units
				Min	Max.	
Address hold time	A0	$t_{AH8}$	--	0	--	ns
Address setup time		$t_{AW8}$		0	--	ns
System cycle time	A0	$t_{CYC8}$	--	240		
Control L pulse width (WR)	WR	$t_{CCLW}$	--	80	--	ns
Control L pulse width (RD)	RD	$t_{CCLR}$		140	--	ns
Control H pulse width (WR)	WR	$t_{CCHW}$		80	--	ns
Control H pulse width (RD)	RD	$t_{CCHR}$		80	--	ns
RD access time	D0 to D7	$t_{DS8}$	--	40	--	ns
		$t_{DH8}$		10	--	ns
Output disable time	D7	$t_{ACC8}$	$C_L=100pF$	--	70	ns
		$t_{OH8}$		5	50	ns

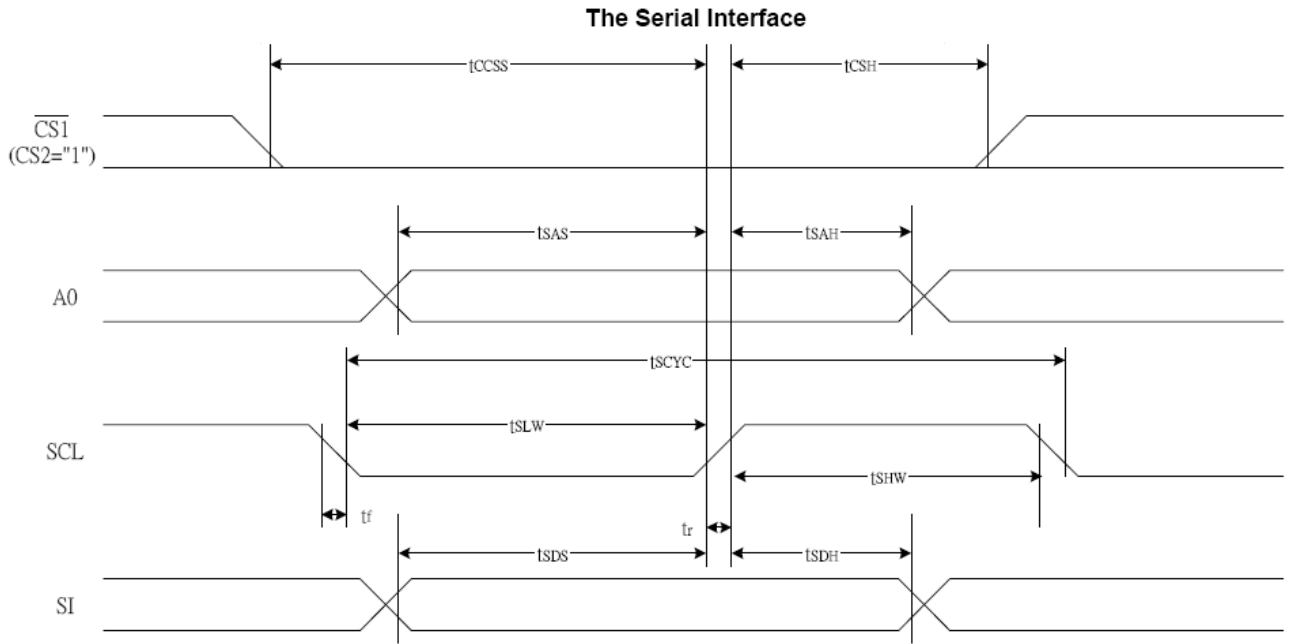

Item	Signal	Symbol	Condition	Rating		Units
				Min	Max.	
Serial Clock Period	SCL	Tsyc		50	--	ns
SCL "H" pulse width		Tshw		25	--	ns
SCL "L" pulse width		TSLW		25	--	ns
Address setup time	A0	TSAS		20	--	ns
Address hold time		Tsah		10	--	ns
Data setup time	SI	Tsds		20	--	ns
Data hold time		TSDH		10	--	ns
CS-SCL time	CS	Tess		20	--	ns
CS-SCL time		Tesh		40	--	ns

## 5. NOTES

### Safety

- If the LCD panel breaks, be careful not to get the liquid crystal in your mouth. If the liquid crystal touches your skin or clothes, wash it off immediately using soap and plenty of water.

### Handling

- Avoid static electricity as this can damage the CMOS LSI.
- The LCD panel is plate glass; do not hit or crush it.
- Do not remove the panel or frame from the module.
- The polarizing plate of the display is very fragile; handle it very carefully

### Mounting and Design

- Mount the module by using the specified mounting part and holes.
- To protect the module from external pressure, leave a small gap by placing transparent plates (e.g. acrylic or glass ) on the display surface, frame, and polarizing plate
- Design the system so that no input signal is given unless the power-supply voltage is applied.
- Keep the module dry. Avoid condensation, otherwise the transparent electrodes may break.

### Storage

- Store the module in a dark place where the temperature is  $25^{\circ}\text{C}\pm 10^{\circ}\text{C}$  and the humidity below 65% RH.
- Do not store the module near organic solvents or corrosive gases.
- Do not crush, shake, or jolt the module (including accessories).

### Cleaning

- Do not wipe the polarizing plate with a dry cloth, as it may scratch the surface.
- Wipe the module gently with soft cloth soaked with a petroleum benzine.
- Do not use ketonic solvents (ketone and acetone) or aromatic solvents (toluene and xylene), as they may damage the polarizing plate.

## 6. OPERATION PRECAUTIONS

Any changes that need to be made in this specification or any problems arising from it will be dealt with quickly by discussion between both companies.