

Display Elektronik GmbH

DATA SHEET

LCD MODULE

DEM 122032A SYH-LY

Product Specification

Version: 2.1.2

15.07.2019

GENERAL SPECIFICATION

MODULE NO. :

DEM 122032A SYH-LY

CUSTOMER P/N

Version NO.	Change Description	Date
0	First Issue	29.05.2006
1	Change Print	05.09.2006
2	Change LCD-Driver	18.03.2008
2.1.0	Change Production Line	07.01.2019
2.1.1	Correct Vlcd	05.07.2019
2.1.2	Add PCB Description	15.07.2019

PREPARED BY: CC

DATE: 15.07.2019

APPROVED BY: MH

DATE: 15.07.2019

CONTENTS

1. FUNCTIONS & FEATURES	4
2. MECHANICAL SPECIFICATIONS.....	4
3. EXTERNAL DIMENSIONS	5
4. BLOCK DIAGRAM.....	6
5. PIN ASSIGNMENT.....	6
6. PCB DRAWING AND DESCRIPTION	7
7. BACKLIGHT ELECTRICAL/OPTICAL SPECIFICATIONS	8
8. MAXIMUM ABSOLUTE POWER RATINGS	9
9. ELECTRICAL CHARACTERISTICS	9
10. CONTROL AND DISPLAY COMMAND.....	11
11. LCD ELECTRO-OPTICAL DEFINITION	12
12. LCD ARTWORK	14
13. COMMON LAYOUT	14
14. SEGMENT LAYOUT	15
15. MODULE ACCEPT QUALITY LEVEL (AQL).....	15
16. RELIABILITY TEST	15
17. LCD MODULES HANDLING PRECAUTIONS.....	16
18. OTHERS	16

1. FUNCTIONS & FEATURES

- DEM 122032A SYH-LY LCD Type :

Module	LCD Type	Remark
DEM 122032A SYH-LY	STN Yellow-Green Transflective Positive Mode	-

- Viewing Direction : 6 O'clock
- Driving Scheme : 1/32 Duty Cycle, 1/5 Bias
- Power Supply Voltage : 5.0Volt (typ.)
- LCD Driving Voltage : 3.9Volt (typ.)
- Display contents : 122 x 32 dots
- Interface : Parallel
- Driver IC : PT6520
- RoHS Compliant

2. MECHANICAL SPECIFICATIONS

- Module Size : 80.00mm x 36.00mm x 13.50mm
- Viewing Area : 60.00mm x 18.50mm
- Active Area : 53.66mm x 15.66mm
- Dot Pitch : 0.44 x 0.49
- Dot Size : 0.42 x 0.47

3. EXTERNAL DIMENSIONS

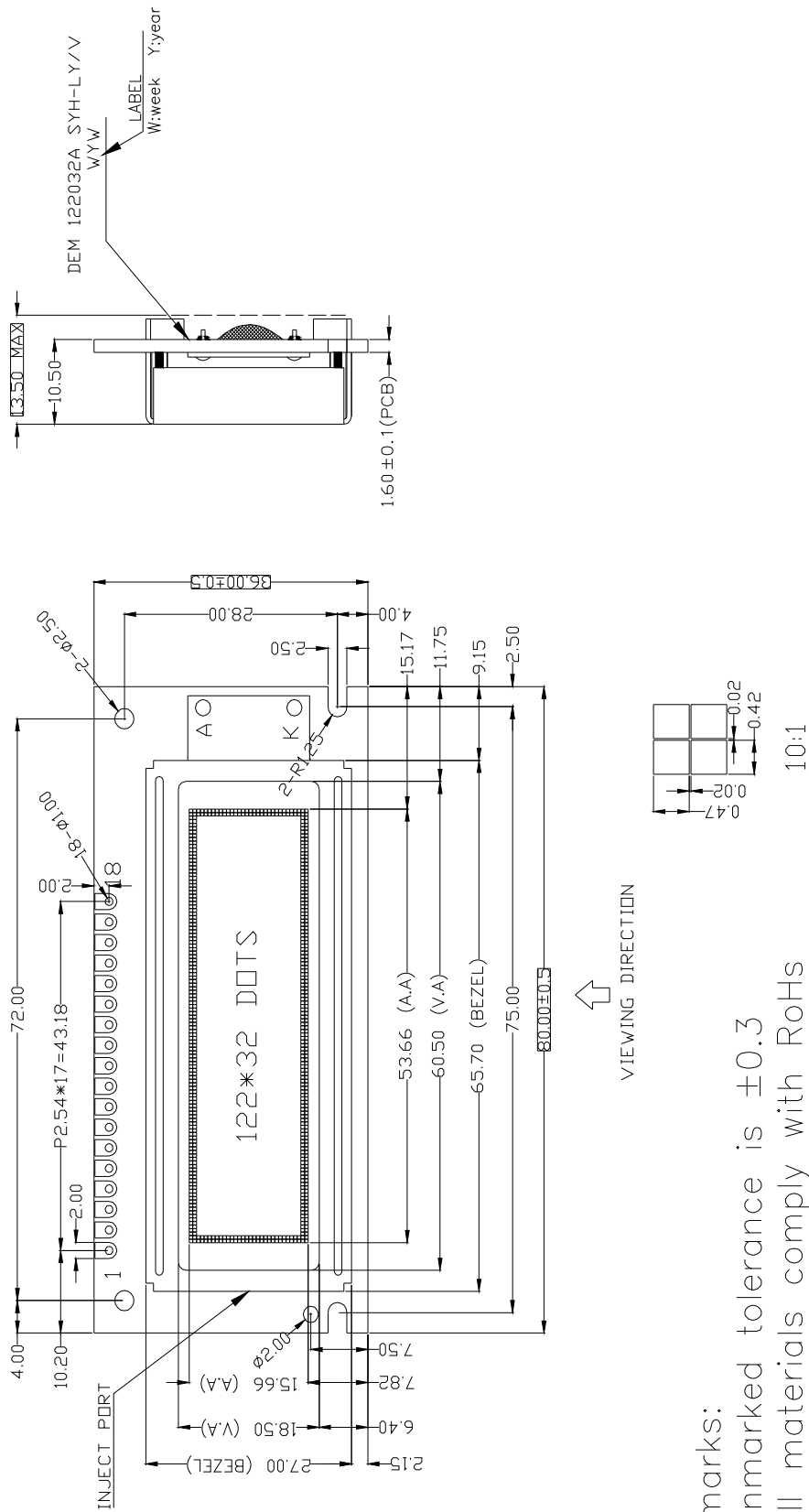

- Remarks:
- 1.Unmarked tolerance is ±0.3
 - 2.All materials comply with RoHs
 3. ...:critical dimension.

4. BLOCK DIAGRAM

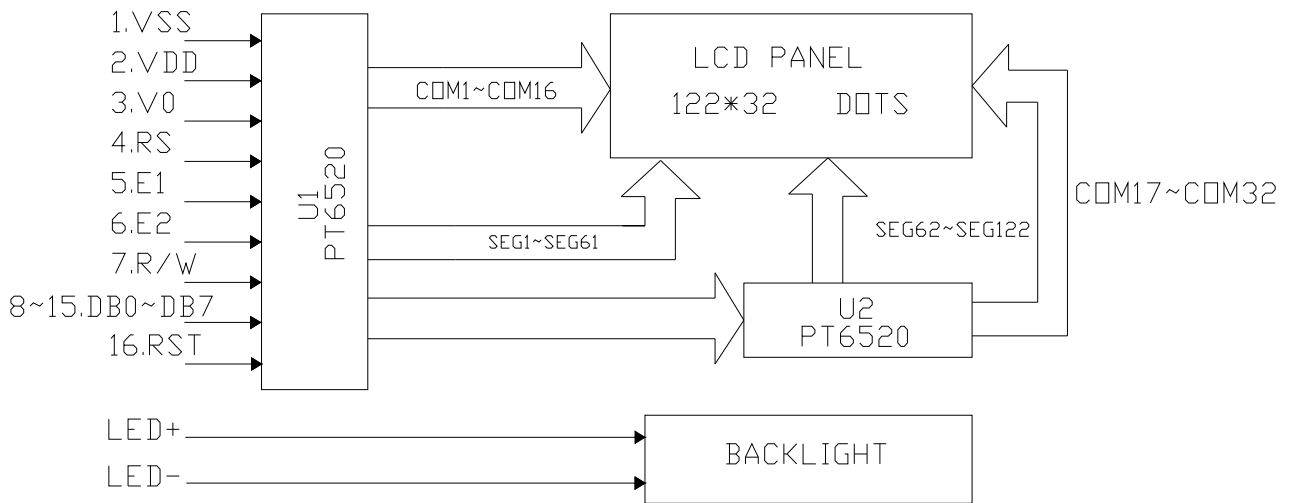

5. PIN ASSIGNMENT

Pin No.	Symbol	Function
1	VSS	GND(0V)
2	VDD	Power Supply (+5V)
3	V0	Supply Voltage for LCD Drive
4	RS	Register Selection. (H: Data register L: Instruction register)
5	E1	Enable Signal for IC1(left half of the panel)
6	E2	Enable Signal for IC2(right half of the panel)
7	R/W	Read/Write Selection. (H: Read L: write)
8~15	DB0~DB7	Data Input
16	RST	Reset Signal(The Rise of the Signal is for Active and Keep RST='h')
17	VLED+	Power Supply for Backlight (Current:100m, Reference voltage:5.0V)
18	VLED-	Power Supply for Backlight

6. PCB DRAWING AND DESCRIPTION

6-1 PCB DRAWING

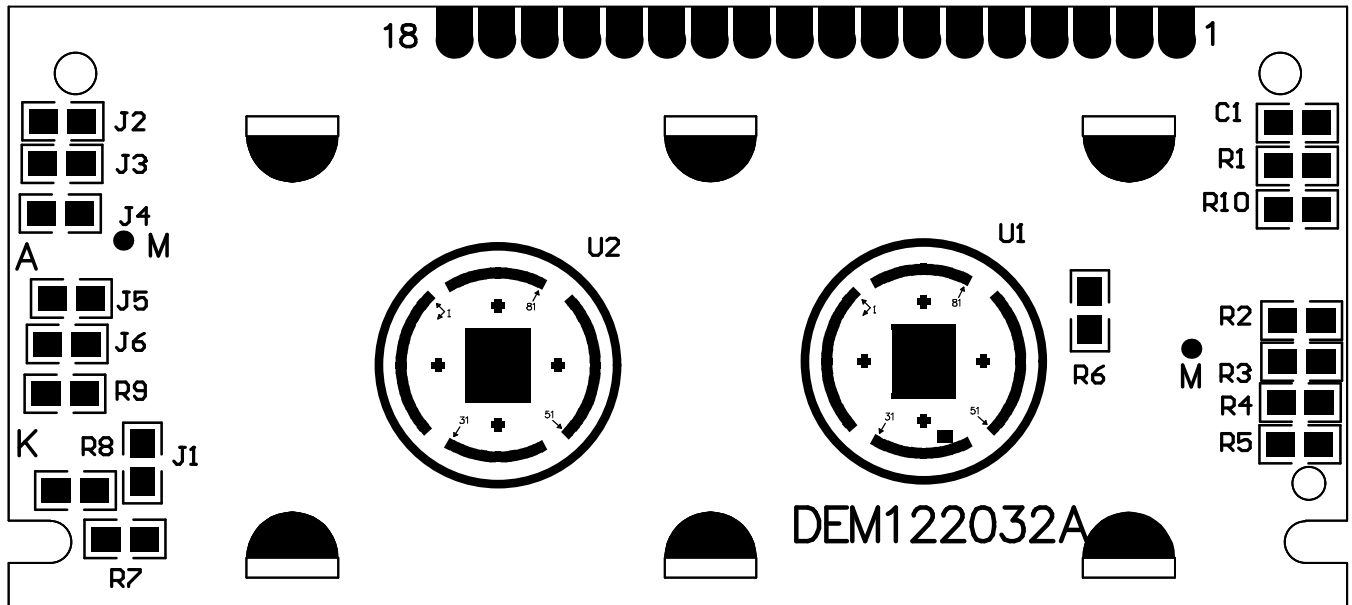

6-2.DESCRPTION:

6-2-1.The polarity of the pin 15 and the pin 16:

J2,J4	J3, J5	LED Polarity	
		17 Pin	18 Pin
Each open	Each closed	Anode	Cathode
Each closed	Each open	Cathode	Anode

Note: In application module: J3=J5=closed, J2=J4=open

6-2-2. The metal-bezel is set on ground when the J1 is closed.

Note: In application module: J1=closed

6-2-3.The LED resistor can be bridged when the J6 is closed.

Note: In application module: J6=open

6-2-4.The R7 and the R8、 R9 is the LED resistor.

Note: R8=8.2Ω, R7= open, R9= open

7. BACKLIGHT ELECTRICAL/OPTICAL SPECIFICATIONS

Item	Symbol	min.	typ.	max.	Unit	Condition
Forward Voltage	Vf	4.0	4.2	4.4	V	If= 100 mA
Power Dissipation	Pd	400	420	440	mW	
Luminous Uniformity	ΔL_v	75			%	MIN/MAX*100%
Luminance	Lv	150	200		cd/m ²	If=100mA T=25°C
Wavelength	λ_D	569	572	575		

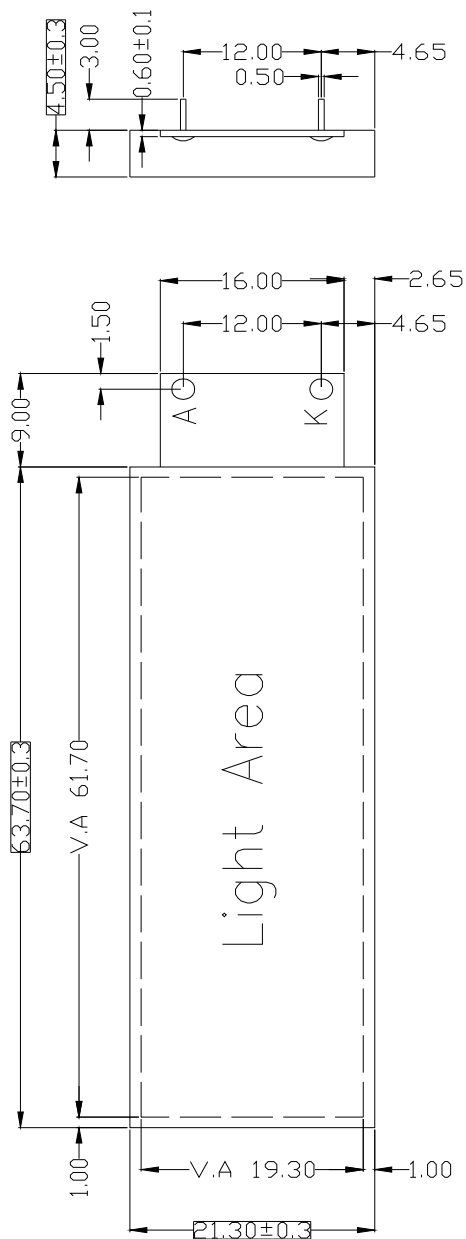

Remarks:
 1. Unmarked tolerance is ±0.3
 2. All materials comply with RoHs
 3. ...:critical dimension.
 4. Color: Yellow-Green

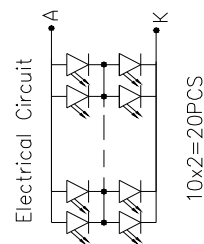

8. MAXIMUM ABSOLUTE POWER RATINGS**(Ta=25°C, VDD=0V)**

Parameter	Symbol	Rating	Unit
Supply Voltage (1)	VSS	-8.0 to 0.3	V
Supply Voltage (2)	V5	-16.5 to 0.3	V
Supply Voltage (3)	V1, V4, V2, V3	V5 to 0.3	V
Input Voltage	V0	VSS -0.3 to 0.3	V
Output Voltage	VIN	VSS -0.3 to 0.3	V
Operating Temperature	Topr	-20 to 70	°C
Storage Temperature	Tstg	-30 to 80	°C

9. ELECTRICAL CHARACTERISTICS**9.1 DC Characteristics****(Ta= 25°C, VSS= 0V)**

Item	Symbol	Standard Value			Test Condition	Unit
		Min.	Typ.	Max.		
Operating Voltage	VDD	4.7	5.0	5.3	--	V
LCD Voltage	VLCD	3.6	3.9	4.2	VDD - V0	V
Supply Current	IDD	--	TBD	--		mA

9.2 AC Characteristics

READ/WRITE TIMING FOR THE 68-PORT MPU

(V_{ss}= -5V, T_a=-20~+70°C)

Parameter	Signal	Symbol	Condition	Min.	Typ.	Max	Unit	
System Cycle Time	A0, CS R/W	tCYC6	VSS=-5V	1000	-	-	ns	
Address Set-Up Time		tAW6	VSS=-5V	20	-	-	ns	
Address Hold Time		tAH6	VSS=-5V	10	-	-	ns	
Control Pulse Width	D0~D7	tDS6	VSS=-5V	80	-	-	ns	
Data Set-Up Time		tDH6	VSS=-5V	10	-	-	ns	
Data Hold Time		tOH6	CL=100pF VSS=-5V	10	-	60	ns	
RD Access Time		tACC6	CL=100pF VSS=-5V	-	-	200	ns	
Enable Disable Time	READ	E	tew	VSS=-5V	250	-	-	ns
	WRITE			VSS=-5V	150	-	-	ns

READ/WRITE TIMING FOR THE 68-PORT MPU

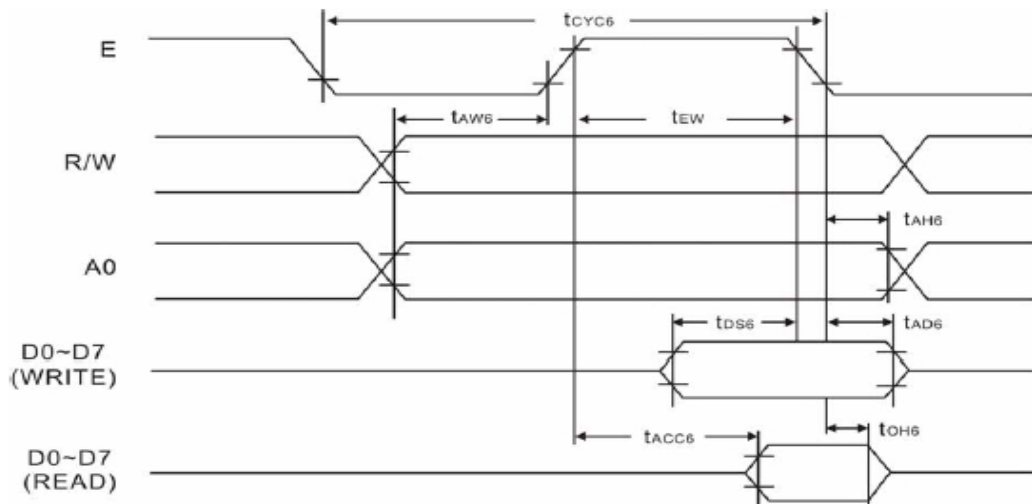

10. CONTROL AND DISPLAY COMMAND

Command		RD	WR	A0	D7	D6	D5	D4	D3	D2	D1	D0	Function
1	Display ON/OFF	1	0	0	1	0	1	0	1	1	1	0/1	Switches the entire display ON or OFF, regardless of the Display RAM's data or the internal status. *
2	Display START Line	1	0	0	1	1	0	Display START address (0-31)					Determines the line of RAM data to be displayed at the display's top line (COM0)
3	Page Address Set	1	0	0	1	0	1	1	1	0	Page (0-3)		Sets the page of the Display RAM in the page address register.
4	Column (segment) Address Set	1	0	0	0	Column address (0-79)						Sets the column address of the Display RAM in the column address register.	
5	Status Read	0	1	0	BUSY	ACC	ON/OFF	RESET	0	0	0	0	Read the status. Busy 1: Busy (internal processing) 0: Ready status ADC 1: Rightward (forward) output 0: Leftward (reverse) output ON/OFF 1: Display OFF 0: Display ON RESET 1: Resetting. 0: Normal
6	Write Display Data	1	0	1	Write Data						Writes the data on the data bus to RAM	These commands access a previously-specified address of the Display RAM, after which the column address is incremented by one.	
7	Read Display Data	0	1	1	Read Data						Reads data from the Display RAM onto the data bus.		
8	ADC Select	1	0	0	1	0	1	0	0	0	0	0/1	Used to reverse the correspondence between the Display RAM's column address and segment driver output ports 0: Rightward (forward) output 1: Leftward (reverse) output
9	Static Drive ON/OFF	1	0	0	1	0	1	0	0	1	0	0/1	Selects normal display operation or static all-lit drive display operation. 1: Static drive (power save)* 0: Normal display operation
10	Duty Select	1	0	0	1	0	1	0	1	0	0	0/1	Selects the duty factor for driving LCD cells. 1: 1/32 duty, 0: 1/16 duty
11	Read Modify Write	1	0	0	1	1	1	0	0	0	0	0	Increments column address counter by 1 when display is written. (This is not done when data is read)
12	End	1	0	0	1	1	1	0	1	1	1	0	Cancels the Ready Modify Write mode.
13	Reset	1	0	0	1	1	1	0	0	0	1	0	Resets the display START line to the 1st line in the register. Resets the column address counter to 0 and page address to 0.

11. LCD ELECTRO-OPTICAL DEFINITION

Optical Characteristics

Item	Symbol	Description	Condition	Min	Typ	Max	Unt
Operating Voltage of	Vop	---	-20°C	4.6	5.0	5.4	V
			25°C	3.6	3.9	4.2	
			70°C	3.6	4.0	4.4	
Response Time	Tr	Rise	Ta=25°C	---	185	---	ms
	Tf	Fall		---	200	---	ms
Contrast	Cr		Ta=25°C	---	4	---	---
Viewing Angle	θ	6 o'clock axis	$Cr \geq 2$	---	40	---	deg
		12 o'clock axis		----	40	---	deg
		3 o'clock axis		---	40	---	deg
		9 o'clock axis		---	40	---	deg

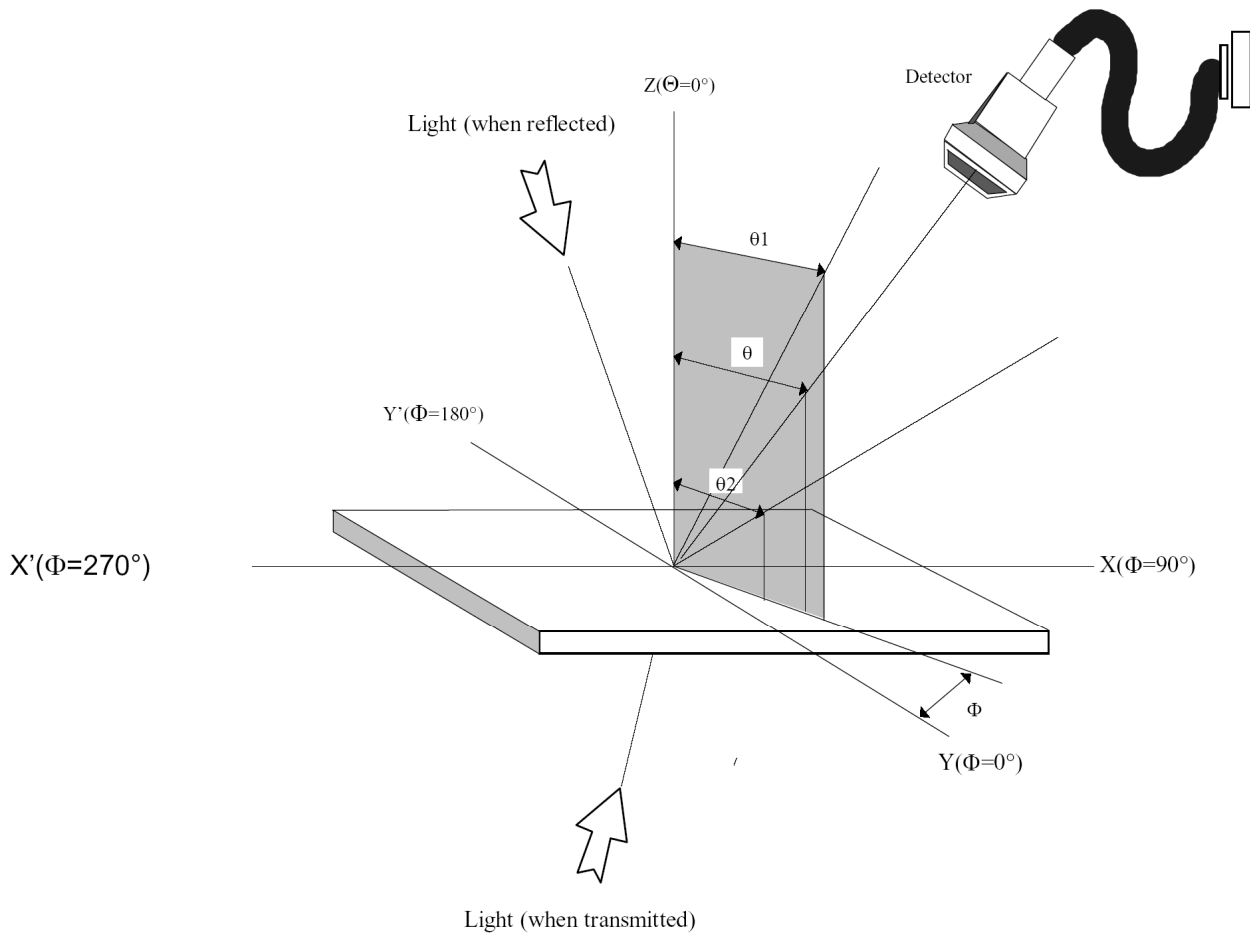

Definition of contrast $Cr. = \frac{B2}{B1} = \frac{\text{Bright curve of not selected segment}}{\text{Bright curve of selected segment}}$

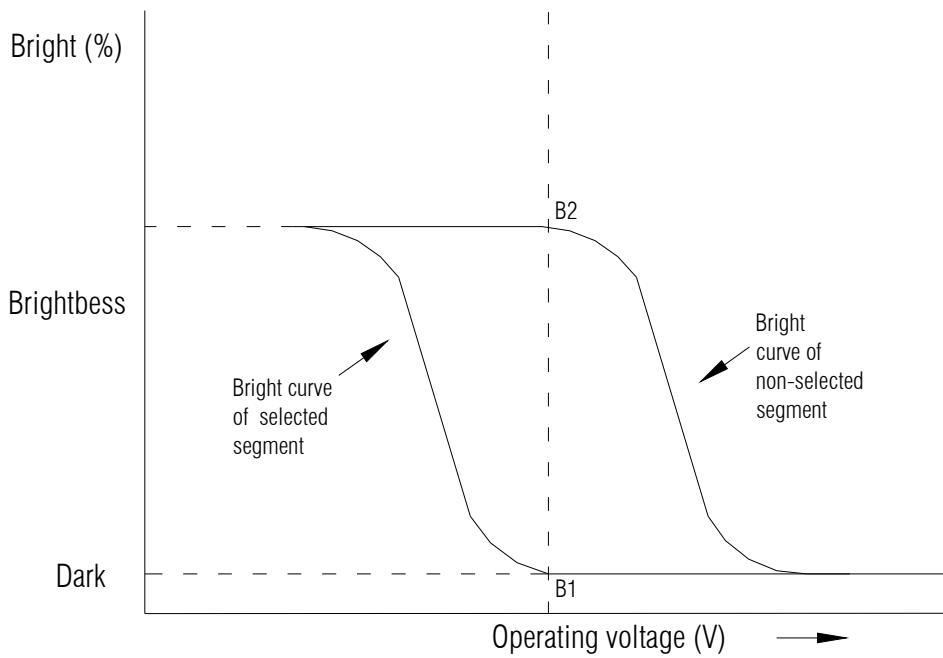

Definition of viewing angle $\theta 1$ and $\theta 2$

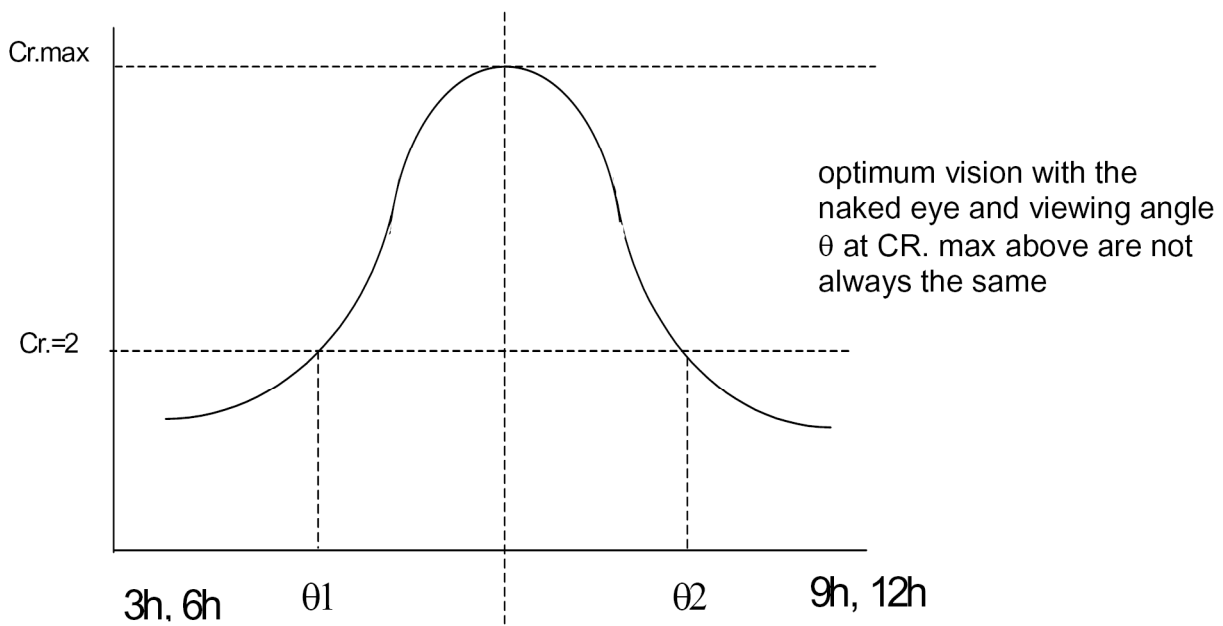

12. LCD ARTWORK

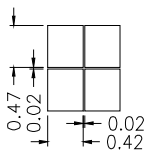
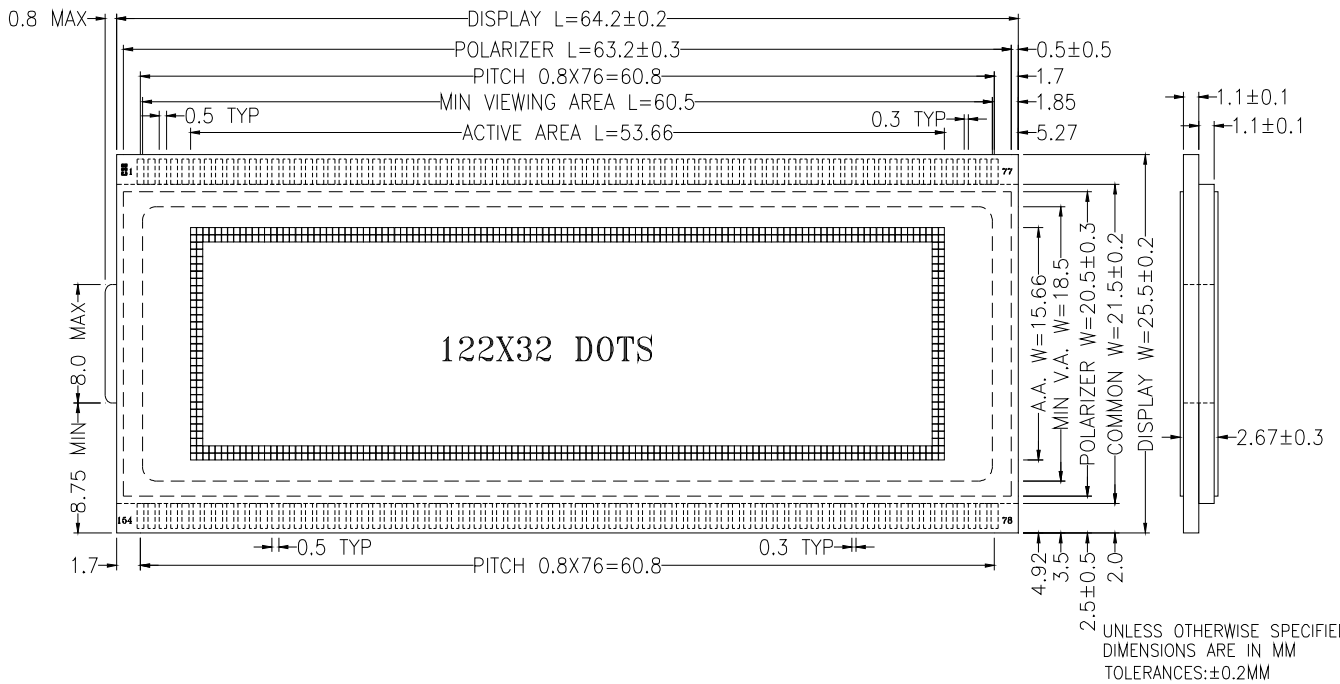

(15 : 1)

UNLESS OTHERWISE SPECIFIED
DIMENSIONS ARE IN MM
TOLERANCES:±0.1MM

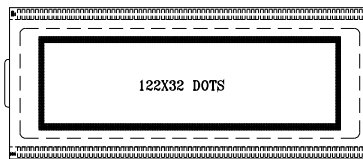

(1 : 1)

13. COMMON LAYOUT

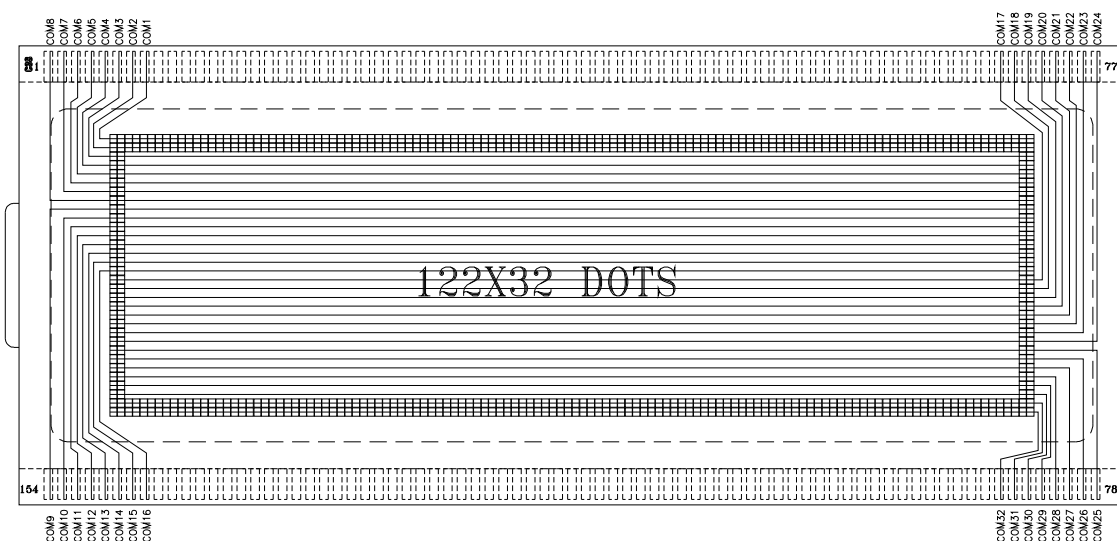

14. SEGMENT LAYOUT

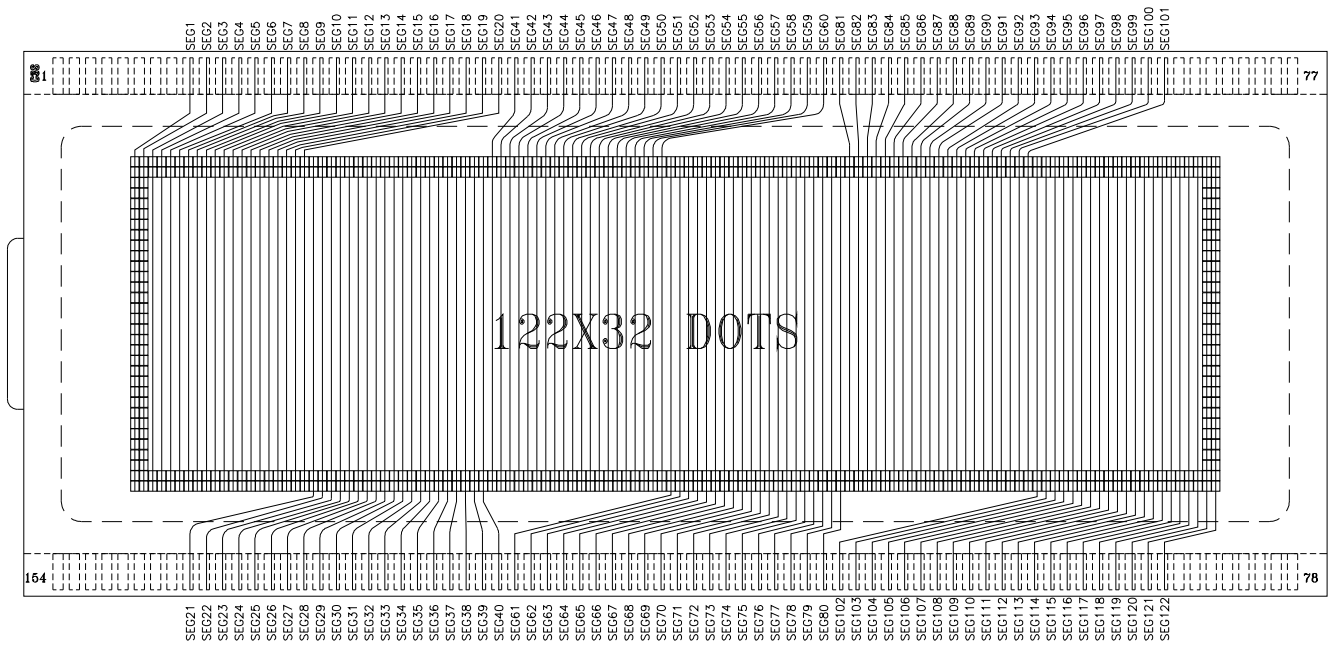

15. MODULE ACCEPT QUALITY LEVEL (AQL)

15.1. Inspection Standard: MIL-STD-105E Table Normal Inspection Single Sampling Level II.

16. RELIABILITY TEST

Operating life time: 50,000 Hours (at room temperature without direct irradiation of sunlight)

Reliability characteristics shall meet following requirements.

Tests Item	Condition
High Temperature Storage	+80°C x 96 hrs
Low Temperature Storage	-30°C x 96 hrs
High Temperature Operation	+70°C x 96 hrs
Low Temperature Operation	-20°C x 96 hrs
High Temperature, High Humidity	+60°C x 90%RH x 96 hrs
Thermal Shock	0°C x 30min → 25°C x 10s → +70°C x 30 min x 5 cycles
Vibration Test	Frequency x Swing x Time 40Hz x 4mm x 4hrs
Drop Test	Height x no. of drop 1.0m x 6 drops

17. LCD MODULES HANDLING PRECAUTIONS

- Please remove the protection foil of polarizer before using.
- The display panel is made of glass. Do not subject it to a mechanical shock by dropping it from a high place, etc.
- If the display panel is damaged and the liquid crystal substance inside it leaks out, do not get any in your mouth. If the substance come into contact with your skin or clothes promptly wash it off using soap and water.
- Do not apply excessive force to the display surface or the adjoining areas since this may cause the color tone to vary.
- The polarizer covering the display surface of the LCD module is soft and easily scratched. Handle this polarize carefully.
- To prevent destruction of the elements by static electricity, be careful to maintain an optimum work environment.
 - Be sure to ground the body when handling the LCD module.
 - Tools required for assembly, such as soldering irons, must be properly grounded.
 - To reduce the amount of static electricity generated, do not conduct assembly and other work under dry conditions.
 - The LCD module is coated with a film to protect the display surface. Exercise care when peeling off this protective film since static electricity may be generated.
- Storage precautions

When storing the LCD modules, avoid exposure to direct sunlight or to the light of fluorescent lamps. Keep the modules in bags designed to prevent static electricity charging under low temperature / normal humidity conditions (avoid high temperature / high humidity and low temperatures below 0°C). Whenever possible, the LCD modules should be stored in the same conditions in which they were shipped from our company.

18. OTHERS

- Liquid crystals solidify at low temperature (below the storage temperature range) leading to defective orientation of liquid crystal or the generation of air bubbles (black or white). Air bubbles may also be generated if the module is subjected to a strong shock at a low temperature.
- If the LCD modules have been operating for a long time showing the same display patterns may remain on the screen as ghost images and a slight contrast irregularity may also appear. Abnormal operating status can be resumed to be normal condition by suspending use for some time. It should be noted that this phenomena does not adversely affect performance reliability.
- To minimize the performance degradation of the LCD modules resulting from caused by static electricity, etc. exercise care to avoid holding the following sections when handling the modules:
 - Exposed area of the printed circuit board
 - Terminal electrode sections