

Display Elektronik GmbH

DATA SHEET

TFT MODULE

**DEM 800480N2 TMH-PW-N
(A-TOUCH)**

7,0“ TFT + Touch

Product Specification

Ver.: 3.1.0

26.01.2018

Revision History

VERSION	DATE	REVISED PAGE NO.	Note
0	01.09.2014		Preliminary
1	01.09.2014		First Issue
1.1.1	26.03.2015		Add size & Surface Modify Block Diagram & TouchPanel.
2	28.04.2015		Modify Reliability
3	21.01.2016		Modify Static electricity test
3.1.0	26.01.2018		New polarizer, improved brightness

Contents

1. Summary
2. General Specification
3. Interface
4. Contour Drawing
5. Block Diagram
6. Absolute Maximum Ratings
7. Electrical Characteristics
8. Timing characteristics
9. Optical Characteristics
10. Reliability
11. Touch Panel Information

1. Summary

TFT 7.0" is a TN transmissive type color active matrix TFT liquid crystal display that use amorphous silicon TFT as switching devices. This module is composed of a TFT-LCD module. It is usually designed for industrial application and this module follows RoHs.

2. General Specifications

- Size: 7.0 inch
- Dot Matrix: 800 x RGB x 480 dots
- Module dimension: 165.00 x 100.00 x 7.2 mm
- Active area: 154.08 x 85.92 mm
- Dot pitch: 0.0642 x 0.179 mm
- LCD type: TFT, Normally White, Transmissive
- View Direction: 12 o'clock
- Gray Scale Inversion Direction: 6 o'clock
- Aspect Ratio: 16:9
- Backlight Type: LED, Normally White
- With /Without TP: With RTP
- Surface: Anti-Glare

*Color tone slight changed by temperature and driving voltage.

3. Interface

3.1. LCM PIN Definition

FPC Connector is used for the module electronics interface. The recommended model is FH12A-50S-0.5SH manufactured by Hirose

Pin No,	Symbol	I/O	Function	Remark
1	VLED+	P	Power supply for backlight	Note 8
2	VLED+	P	Power supply for backlight	Note 8
3	VLED-	P	Backlight ground	Note 8
4	VLED-	P	Backlight ground	Note 8
5	GND	P	Power ground	
6	VCOM	I	Common voltage	
7	VCC	P	Power for digital circuit	
8	MODE	I	DE/SYNC mode select	Note 1
9	DE	I	Data input enable	
10	VS	I	Vertical Sync input	
11	HS	I	Horizontal sync input	
12	B7	I	Blue data (MSB)	
13	B6	I	Blue data	
14	B5	I	Blue data	
15	B4	I	Blue data	
16	B3	I	Blue data	
17	B2	I	Blue data	
18	B1	I	Blue data	Note 2
19	B0	I	Blue data(LSB)	Note 2
20	G7	I	Green data(MSB)	
21	G6	I	Green data	
22	G5	I	Green data	
23	G4	I	Green data	
24	G3	I	Green data	
25	G2	I	Green data	
26	G1	I	Green data	Note 2
27	G0	I	Green data(LSB)	Note 2
28	R7	I	Red data(MSB)	
29	R6	I	Red data	
30	R5	I	Red data	
31	R4	I	Red data	
32	R3	I	Red data	
33	R2	I	Red data	Note 2
34	R1	I	Red data	Note 2
35	R0	I	Red data(LSB)	
36	GND	P	Power ground	
37	DCLK	I	Sample clock	Note 3
38	GND	P	Power ground	
39	L/R	I	Left /right selection	Note 4,5
40	U/D	I	Up/ down selection	Note 4,5
41	VGH	P	Gate ON voltage	
42	VGL	P	Gate OFF voltage	

43	AVDD	P	Power for analog circuit	
44	RESET	I	Global reset pin	Note 6
45	NC	-	No connection	
46	VCOM	I	Common voltage	
47	DITHB	I	Dithering function	Note 7
48	GND	P	Power ground	
49	NC	-	No connection	
50	NC	-	No connection	

I: input O: output P: power

Note 1: DE/SYNC mode select. Normally pull high.

When select DE mode, MODE= "1", VS and HS must pull high.

When select SYNC mode, MODE= "0", DE must be grounded.

Note 2: When input 18 bits RGB data, the two low bits of R,G and B data must be grounded.

Note 3: Data shall be latched at the falling edge of DCLK.

Note 4: Selection of scanning mode

Setting of scan control input		Scanning direction
U/D	L/R	
GND	VCC	Up to down, left to right
VCC	GND	Down to up, right to left
GND	GND	Up to down, right to left
VCC	VCC	Down to up, left to right

Note 5: Definition of scanning direction

Refer to the figure as below:

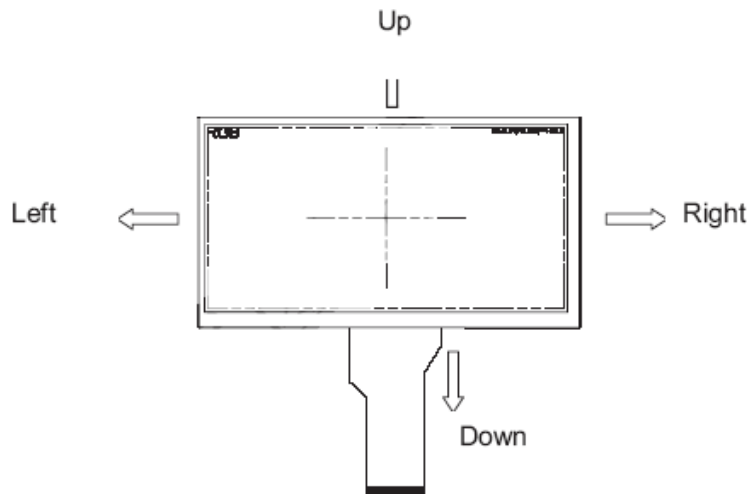

Note 6 : Global reset pin. Active low to enter reset state. Suggest to connect with an RC reset circuit for stability. Normally pull high.

Note 7: Dithering function enable control, normally pull high.

When DITHB="1", Disable internal dithering function.

When DITHB="0", Enable internal dithering function.

Note 8: Reserve for LED power input.,

4. Contour Drawing

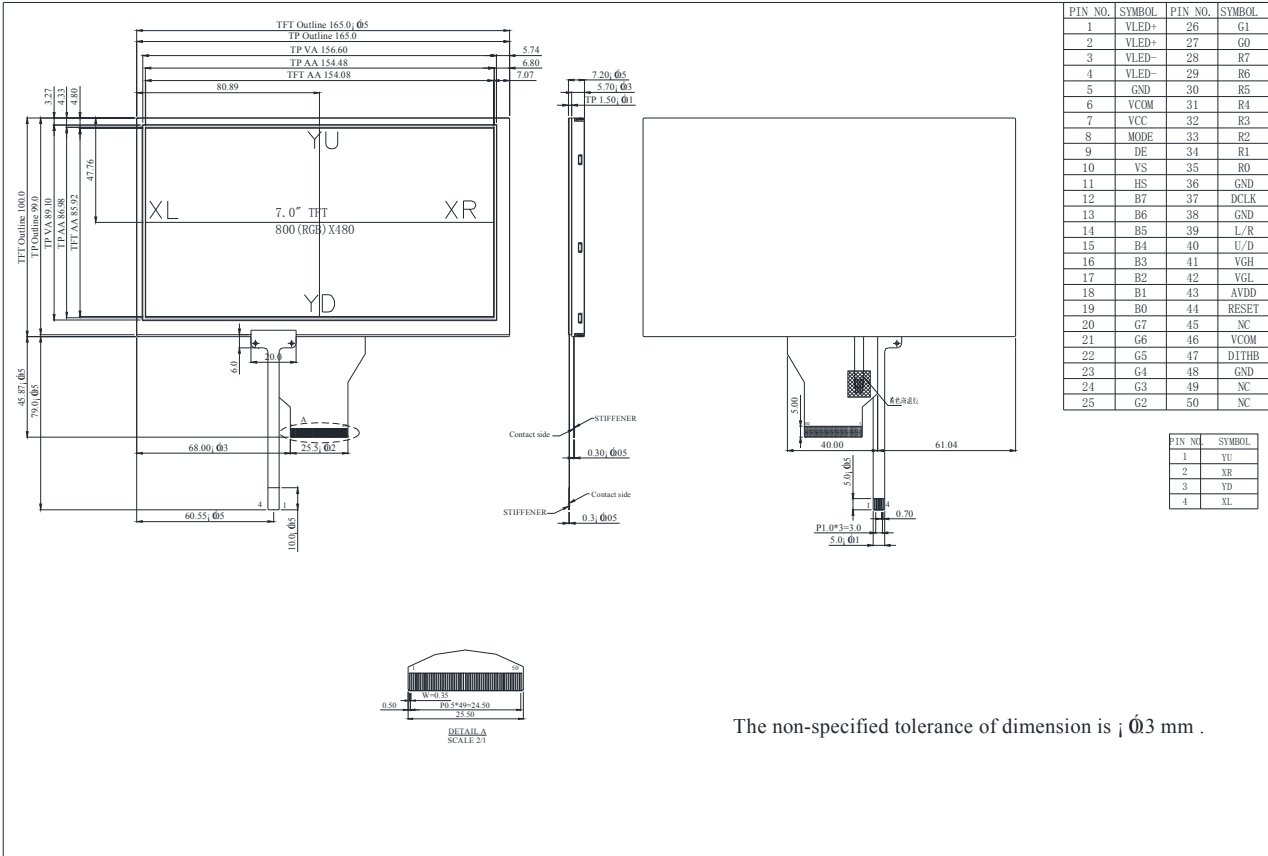

5. Block Diagram

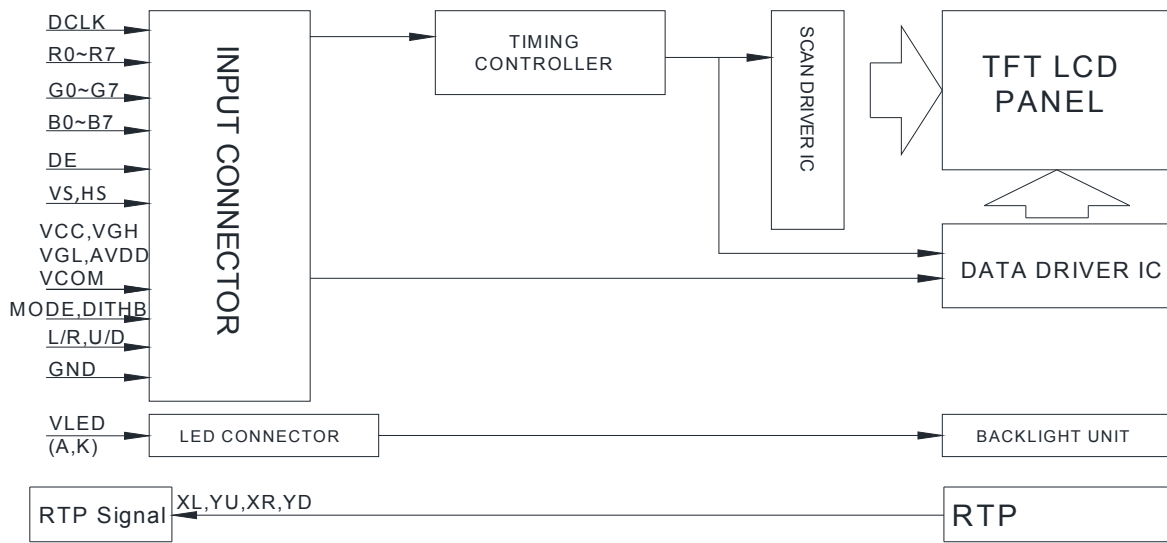

6. Absolute Maximum Ratings

Item	Symbol	Min	Typ	Max	Unit
Operating Temperature	TOP	-20	—	+70	°C
Storage Temperature	TST	-30	—	+80	°C

Note: Device is subject to be damaged permanently if stresses beyond those absolute maximum ratings listed above

1. Temp. $\leq 60^{\circ}\text{C}$, 90% RH MAX. Temp. $> 60^{\circ}\text{C}$, Absolute humidity shall be less than 90% RH at 60°C

7. Electrical Characteristics

7.1. Typical Operation Conditions

Item	Symbol	Values			Unit	Remark
		Min.	Typ.	Max.		
Power voltage	VCC	3.0	3.3	3.6	V	
	AVDD	10.2	10.4	10.6	V	
	VGH	15.3	16.0	16.7	V	
	VGL	-7.7	-7.0	-6.3	V	
Input signal voltage	VCOM	2.6	3.6	4.6	V	
Input logic high voltage	VIH	0.7VCC	-	VCC	°C	
Input logic low voltage	VIL	0	-	0.3VCC	°C	

Note 1: Be sure to apply VCC and VGL to the LCD first, and then apply VGH.

Note 2: VCC setting should match the signals output voltage (refer to Note 3) of customer's system board.

Note 3: DCLK,HS,VS,RESET,U/D, L/R,DE,R0~R7,G0~G7,B0~B7,MODE,DITHB.

Note 4: Typical VCOM is only a reference value. It must be optimized according to each LCM. Please use VR and base on below application circuit.

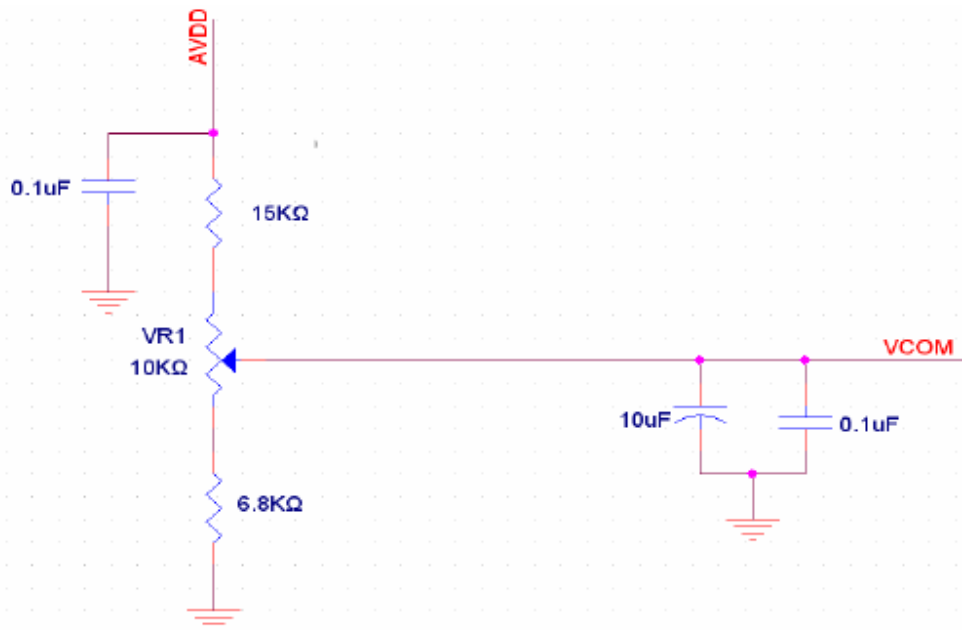

7.2. Current Consumption

Item	Symbol	Values			Unit	Remark
		Min.	Typ.	Max.		
Current for Driver	IGH	-	0.2	1.0	mA	VGH =16.0V
	IGL	-	0.2	1.0	mA	VGL = -7.0V
	IVCC	-	4.0	10	mA	VCC =3.3V
	IAVDD	-	20	50	mA	AVDD =10.4V

7.3. Backlight driving conditions

Parameter	Symbol	Min.	Typ.	Max.	Unit	Note
Supply voltage of white LED backlight	VL	8.7	9.6	10.5	V	Note 1
Curt for LED backlight	IL	135	180	225	mA	
LED life time	-	20,000	-	-	Hr	Note 2

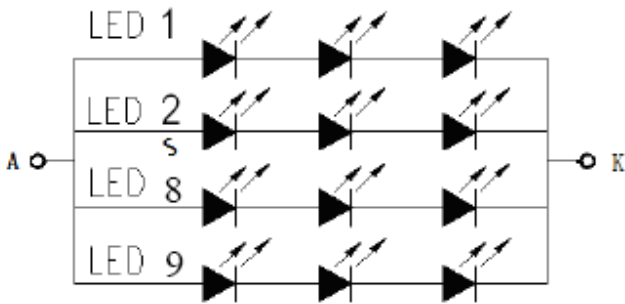

8. Timing characteristics

8.1. AC Electrical Characteristics

Item	Symbol	Values			Unit	Remark
		Min.	Typ.	Max.		
HS setup time	Thst	8	-	-	ns	
HS hold time	Thhd	8	-	-	ns	
VS setup time	Tvst	8	-	-	ns	
VS hold time	Tvhd	8	-	-	ns	
Data setup time	Tdsu	8	-	-	ns	
Data hole time	Tdhd	8	-	-	ns	
DE setup time	Tesu	8	-	-	ns	
DE hole time	Tehd	8	-	-	ns	
Vcc Power On Slew rate	TPOR	-	-	20	ms	From 0 to 90% VCC
RESET pulse width	TRst	1	-	-	ms	
DCLK cycle time	Tcoh	20	-	-	ns	
DCLK pulse duty	Tcwh	40	50	60	%	

9.2. Input Clock and Data Timing Diagram

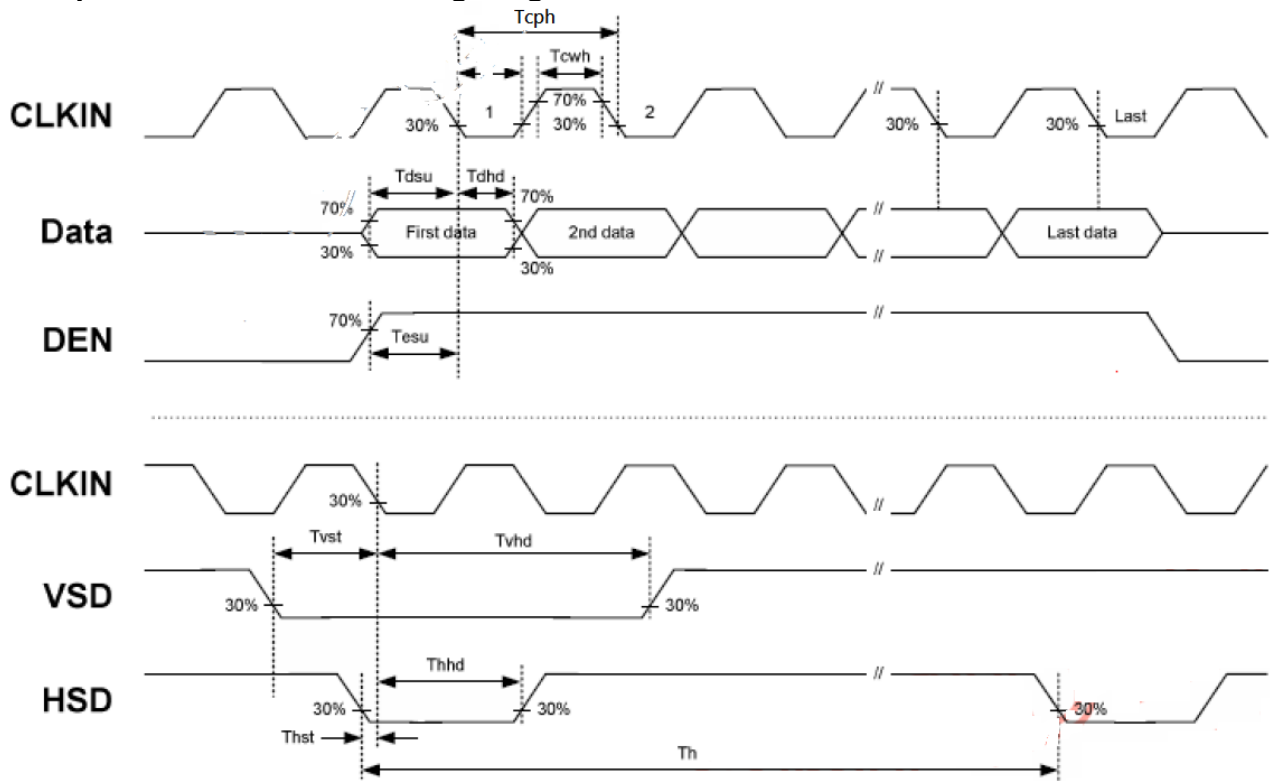

8.3. Timing

Item	Symbol	Values			Unit	Remark
		Min.	Typ.	Max.		
Horizontal Display Area	thd	-	800	thd	DCLK	
DCLK Frequency	fclk	26.4	33.3	46.8	MHz	
One Horizontal Line	Th	862	1056	1200	DCLK	
HS pulse width		1	-	40	DCLK	
HS Blanking	thb	46	46	46	DCLK	
HS Front Porch	Thfp	16	210	354	DCLK	

Item	Symbol	Values			Unit	Remark
		Min.	Typ.	Max.		
Vertical Display Area	tvd	-	480	-	TH	
VS period time	tv	510	525	650	TH	
VS pulse width	vpw	1	-	20	TH	
VS Blanking	tvb	23	23	23	TH	
VS Front Porch	tvfp	7	22	147	TH	

8.4. Data Input Format

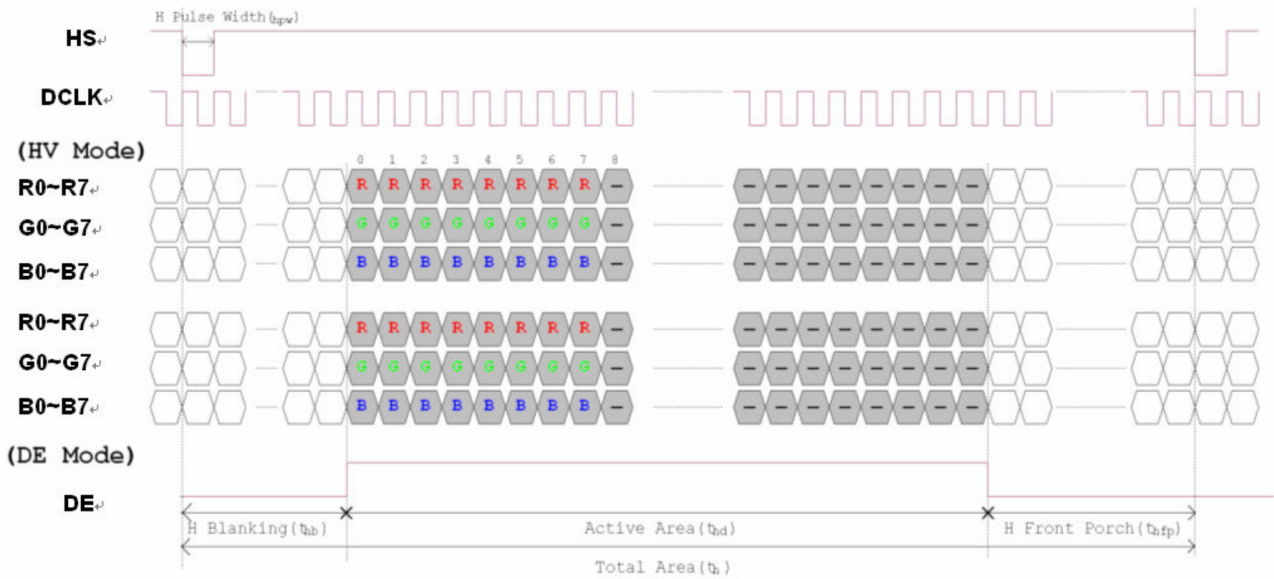

Figure Horizontal input timing diagram

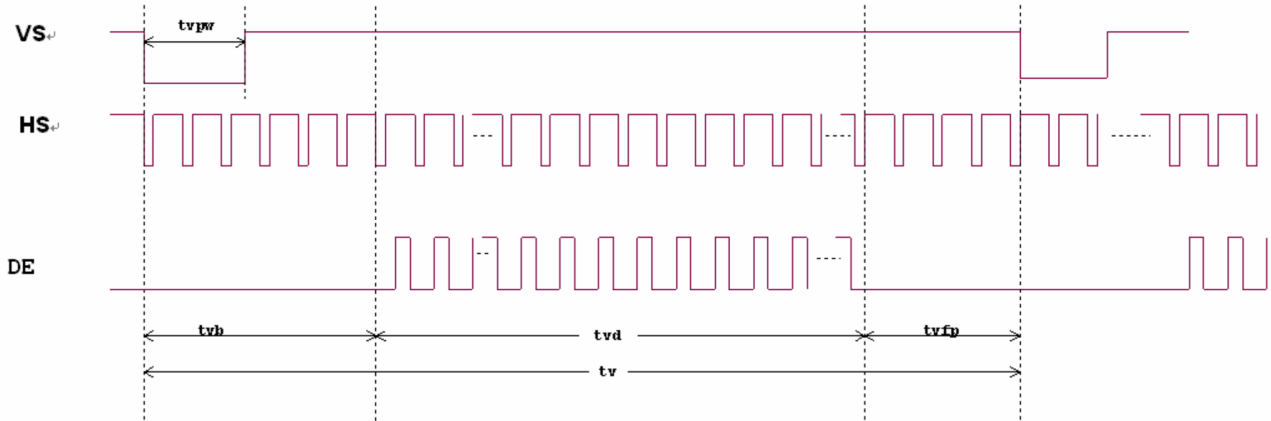

Figure Vertical input timing diagram

9. Optical Characteristics

Item	Symbol	Condition.	Min	Typ.	Max.	Unit	Remark	
Response time	T_r	$\theta=0^\circ, \Phi=0^\circ$	-	10	20	.ms	Note 3	
	T_f		-	15	30	.ms		
Contrast ratio	CR	At optimized viewing angle	400	500	-	-	Note 4	
Color Chromaticity	White	$\theta=0^\circ, \Phi=0$	W_x	0.273	0.313	0.353	-	Note 2,5,6
			W_y	0.289	0.329	0.369	-	
Viewing angle (Gray Scale Inversion Direction)	Hor.	$CR \geq 10$	θ_R	60	70	-	Deg.	Note 1
			θ_L	60	70	-		
	Ver.		ϕ_T	40	50	-		
			ϕ_B	60	70	-		
Brightness	-	-	300	350	-	cd/m ²	Center of display	

$T_a=25\pm 2^\circ C, I_L=180mA$

Note 1: Definition of viewing angle range

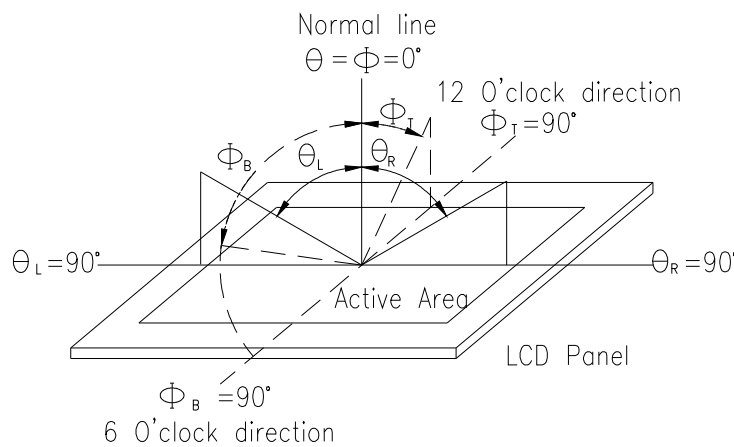

Fig. 10.1. Definition of viewing angle

Note 2: Test equipment setup:

After stabilizing and leaving the panel alone at a driven temperature for 10 minutes, the measurement should be executed. Measurement should be executed in a stable, windless, and dark room. Optical specifications are measured by Topcon BM-7orBM-5 luminance meter 1.0° field of view at a distance of 50cm and normal direction.

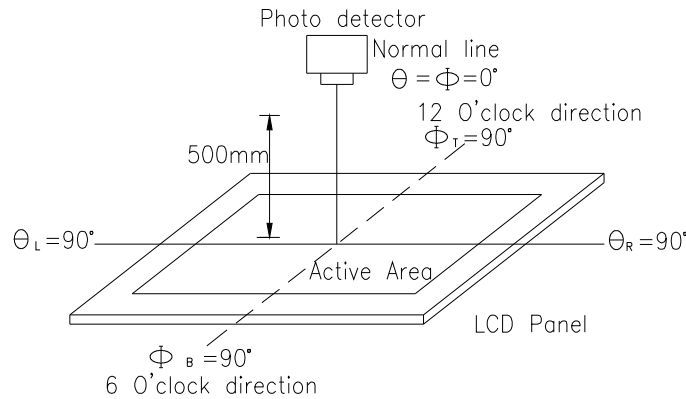
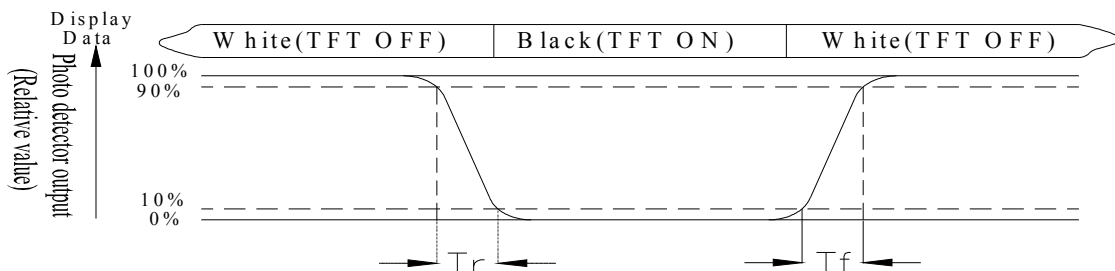

Fig. 10.2. Optical measurement system setup

Note 3: Definition of Response time:

The response time is defined as the LCD optical switching time interval between “White” state and “Black” state. Rise time, T_r , is the time between photo detector output intensity changed from 90% to 10%. And fall time, T_f , is the time between photo detector output intensity changed from 10% to 90%



Note 4: Definition of contrast ratio:

The contrast ratio is defined as the following expression.

$$\text{Contrast ratio (CR)} = \frac{\text{Luminance measured when LCD on the "White" state}}{\text{Luminance measured when LCD on the "Black" state}}$$

Note 5: White $V_i = V_{i50} \pm 1.5V$

Black $V_i = V_{i50} \pm 2.0V$

“±” means that the analog input signal swings in phase with VCOM signal.

“±” means that the analog input signal swings out of phase with VCOM signal.

The 100% transmission is defined as the transmission of LCD panel when all the input terminals of module are electrically opened.

Note 6: Definition of color chromaticity (CIE 1931)

Color coordinates measured at the center point of LCD

Note 7: Measured at the center area of the panel when all the input terminals of LCD panel are electrically opened.

10. Reliability

Content of Reliability Test (Wide temperature, -20°C~70°C)

Environmental Test			
Test Item	Content of Test	Test Condition	Note
High Temperature storage	Endurance test applying the high storage temperature for a long time.	80°C 200hrs	2
Low Temperature storage	Endurance test applying the low storage temperature for a long time.	-30°C 200hrs	1,2
High Temperature Operation	Endurance test applying the electric stress (Voltage & Current) and the thermal stress to the element for a long time.	70°C 200hrs	—
Low Temperature Operation	Endurance test applying the electric stress under low temperature for a long time.	-20°C 200hrs	1
High Temperature/ Humidity Operation	The module should be allowed to stand at 60□,90%RH max	60°C,90%RH 96hrs	1,2
Thermal shock resistance	The sample should be allowed stand the following 10 cycles of operation <div style="text-align: center;"> <p style="margin: 0;">-20°C 25°C 70°C</p> <p style="margin: 0;">30min 5min 30min</p> <p style="margin: 0;">1 cycle</p> </div>	-20°C/70°C 10 cycles	—
Vibration test	Endurance test applying the vibration during transportation and using.	Total fixed amplitude : 1.5mm Vibration Frequency : 10~55Hz One cycle 60 seconds to 3 directions of X,Y,Z for Each 15 minutes	3
Static electricity test	Endurance test applying the electric stress to the terminal.	VS=±600V(contact) ,±800v(air), RS=330Ω CS=150pF 10 times	—

Note1: No dew condensation to be observed.

Note2: The function test shall be conducted after 4 hours storage at the normal Temperature and humidity after remove from the test chamber.

Note3: The packing have to including into the vibration testing.

11. Touch Panel Information

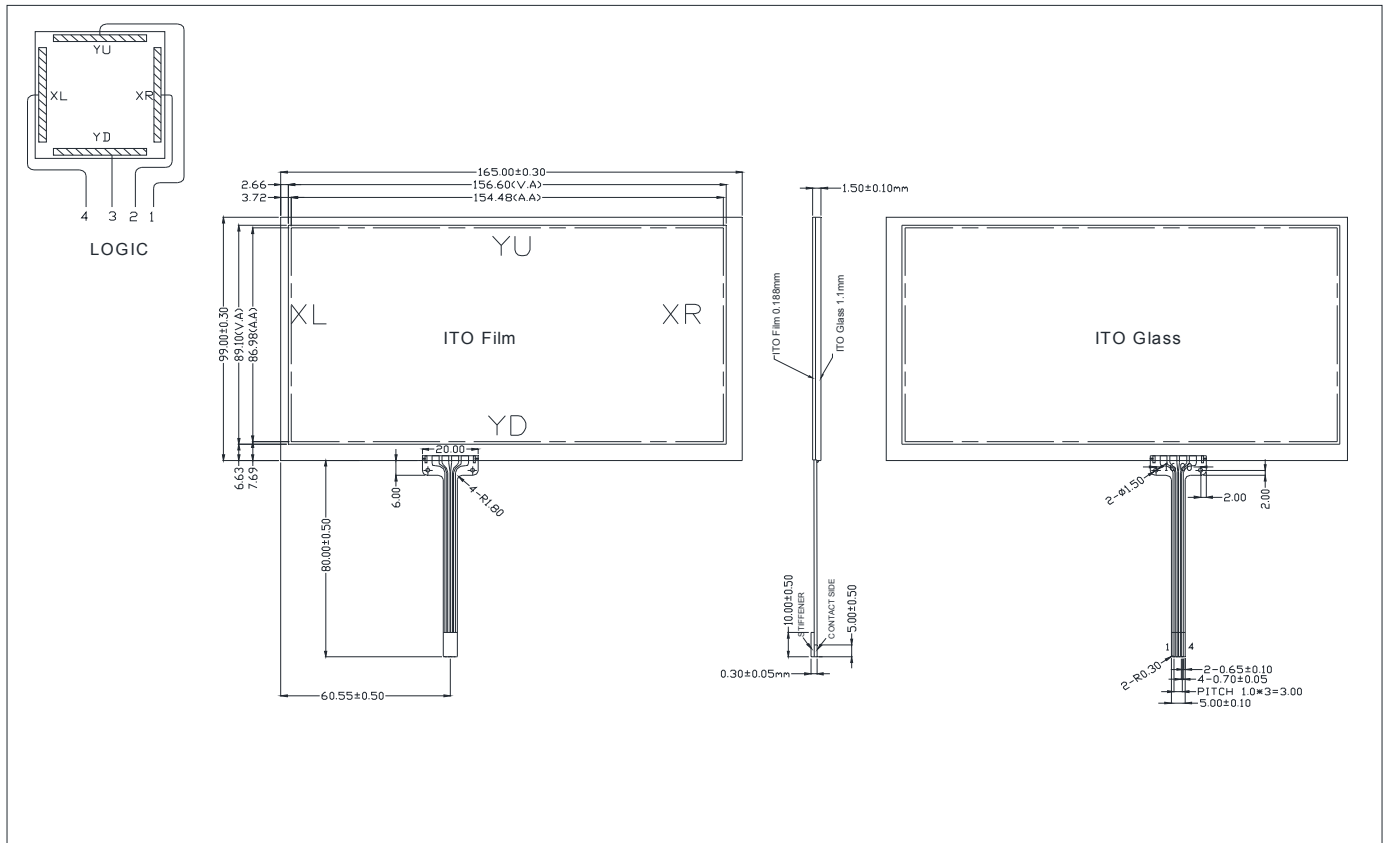

Resistance Touch Panel General Specifications

Item	Description
Driving condition	DC3~7V
Operating force	30~80g
Linearity max	$\leq \pm 1.5\%$
Insulating resistance	$> 10M\Omega$, 25V(DC)
Light transparence	70%
Structure type	ITO Film/ITO Glass(F/G)
Surface Hardness	3H typ
Pen Hitting Durability (with the silicon rubber)	$> 1000,000$ times
X Axis resistance	430~910 Ω
Y Axis resistance	150~530 Ω