

Display Elektronik GmbH

DATA SHEET

TFT MODULE

DEM 800480L TMX-PW-N

8,0" TFT

Product Specification

Ver.: 0

18.10.2013

Revision History

Revision	Date	Detail	Remarks
0	18.10.2013	Initial Release	-

Table of Contents

No.	Item	Page
1.	General Description	4
2.	Module Parameter	4
3.	Absolute Maximum Ratings	4
4.	DC Characteristics	5
5.	Backlight Characteristic	5
5.1.	Backlight Characteristics.....	5
6.	Optical Characteristics	6
6.1.	Optical Characteristics	6
6.2.	Definition of Response Time	6
6.3.	Definition of Contrast Ratio	7
6.4.	Definition of Viewing Angles.....	7
6.5.	Definition of Color Appearance	8
6.6.	Definition of Surface Luminance, Uniformity and Transmittance.....	8
7.	Block Diagram and Power Supply	9
8.	Interface Pins Definition	10
9.	AC Characteristics	12
9.1.	AC Electrical Characteristics.....	12
9.2.	Data Input Format	13
9.3.	Timing.....	14
9.4.	Power Sequence.....	15
10.	Quality Assurance	16
10.1	Purpose.....	16
10.2	Standard for Quality Test.....	16
10.3	Nonconforming Analysis & Disposition	16
10.4	Agreement Items.....	16
10.5	Standard of the Product Visual Inspection	17
10.6	Inspection Specification	17
10.7	Classification of Defects.....	21
10.8	Identification/marketing criteria	21
10.9	Packing	21
11.	Reliability Specification	23
12.	Precautions and Warranty	24
12.1	Safety.....	24
12.2	Handling.....	24
12.3	Storage.....	24
12.4	Metal Pin (Apply to Products with Metal Pins)	24
12.5	Operation	25
12.6	Static Electricity	25
12.7	Limited Warranty.....	25
13.	Packaging	25
14.	Outline Drawing	26

1. General Description

The specification is a transmissive type color active matrix liquid crystal display (LCD) which uses amorphous thin film transistor (TFT) as switching devices. This product is composed of a TFT-LCD panel, driver ICs and a backlight unit.

2. Module Parameter

Features	Details	Unit
Display Size (Diagonal)	8.0"	
LCD Type	TN TFT	
Display Mode	Transmissive /Normal white	
Resolution	800 RGB x 480	Pixels
View Direction	12 O'clock	Best Image
Gray Scale Inversion Direction	6 O'clock	
Module Outline	192.8(H) x116.9(V) x 6.4(T) (Note1)	mm
Active Area	176.64(H) x99.36(V)	mm
Pixel Size	220.8(H) x207 (V)	um
Pixel Arrangement	R.G.B Stripe	
Polarizer Surface Treatment	Anti-Glare	
Display Colors	16.7M	
Interface	24 Bit RGB	
With or without Touch Panel	without	
Operating Temperature	-30~85	°C
Storage Temperature	-30~85	°C
Weight	TBD	g

Note 1: Exclusive hooks, posts, FFC/FPC tail etc.

3. Absolute Maximum Ratings

$V_{SS}=0V$, $T_a=25^{\circ}C$

Item	Symbol	Min.	Max.	Unit
Supply Voltage	VCC	-0.3	5.0	V
Storage temperature	T _{STG}	-30	85	°C
Operating temperature	T _{OP}	-30	85	°C

Note 1: If T_a below $50^{\circ}C$, the maximal humidity is 90%RH, if T_a over $50^{\circ}C$, absolute humidity should be less than 60%RH.

Note 2: The response time will be extremely slow when the operating temperature is around $-10^{\circ}C$, and the back ground will become darker at high temperature operating.

4. DC Characteristics

Item	Symbol	Min.	Typ.	Max.	Unit
Digital Power Supply Voltage	DVDD	3.0	3.3	3.6	V
Analog Power Supply Voltage	AVDD	10.2	10.4	10.6	V
TFT Device on voltage	V _{GH}	15.3	16.0	16.7	V
TFT Device off voltage	V _{GL}	-7.7	-7.0	-6.3	V
Common Electrode Driving Voltage	V _{COM}	3.4	4.4	5.4	V
Low Level Input Voltage	V _{IL}	0	-	0.3*DVDD	V
High Level Input Voltage	V _{IH}	0.7*DVDD	-	DVDD	V

5. Backlight Characteristic

5.1. Backlight Characteristics

Item	Symbol	Condition	Min	Typ	Max	Unit
Forward Voltage	V _F	Ta=25 °C, I _F =20mA/LED	8.4	9.6	10.2	V
Forward Current	I _F	Ta=25 °C, V _F =3.2V/LED	216	240	264	mA
Power Dissipation	P _D		-	2304	-	mW
LED Life Time(25 °C)	-	-	(20,000)	-	-	hr
Uniformity	Avg		70	75	-	%
Drive method	Constant current					
LED Configuration	36 White LEDs(3 LEDs in one string and 12 groups in parallel)					

Note: LED life time defined as follows:The final brightness is at 50% of original brightness.

The environmental conducted under ambient air flow,at Ta=25± 2 °C,60%RH± 5%.

5.2. Backlighting Circuit

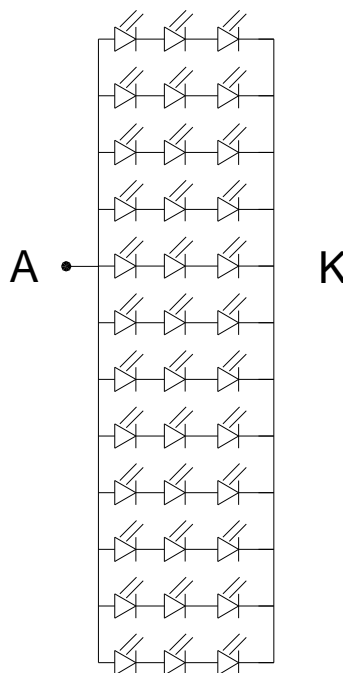

CIRCUIT DIAGRAM

6. Optical Characteristics

6.1. Optical Characteristics

Ta=25°C, DVDD=3.3V, TN LC+ Polarizer

	Item	Symbol	Condition	Specification			Unit	
				Min.	Typ.	Max.		
Backlight On (Transmissive Mode)	Luminance on TFT($I_f=20\text{mA/LED}$)	Lv	Normally viewing angle $\theta_x = \phi_y = 0^\circ$	360	450	-	cd/m ²	
	Contrast ratio(See 6.3)	CR		400	500	-		
	Response time (See 6.2)	T _R		-	10	20	ms	
		T _F	-	15	30			
	Chromaticity Transmissive (See 6.5)	Red	X _R	-	TBD	-		
			Y _R	-	TBD	-		
		Green	X _G	-	TBD	-		
			Y _G	-	TBD	-		
		Blue	X _B	-	TBD	-		
			Y _B	-	TBD	-		
	White	X _W	0.26	0.31	0.36			
		Y _W	0.28	0.33	0.38			
	Viewing Angle (See 6.4)	Horizontal	θ_{x+}	Center CR≥10	60	70	-	Deg.
			θ_{x-}		60	70	-	
Vertical		ϕ_{y+}	40		50	-		
		ϕ_{y-}	60		70	-		

6.2. Definition of Response Time

6.2.1. Normally Black Type (Negative)

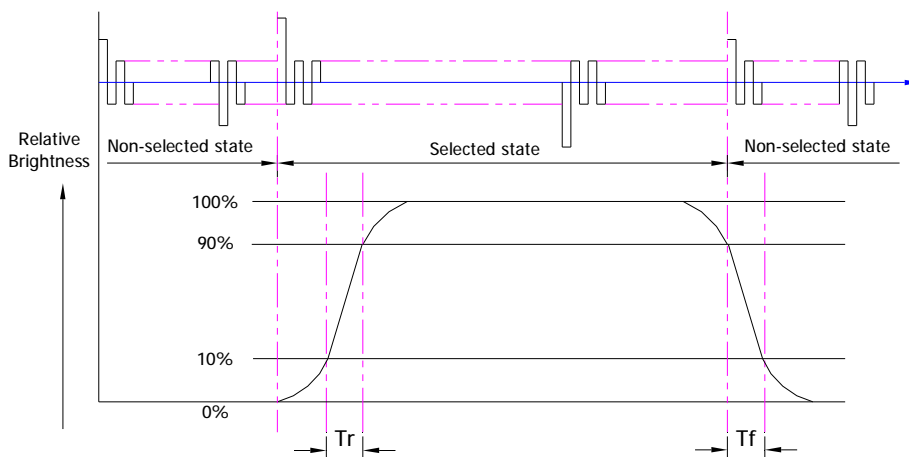

Tr is the time it takes to change from non-selected stage with relative luminance 10% to selected state with relative luminance 90%;

Tf is the time it takes to change from selected state with relative luminance 90% to non-selected state with relative luminance 10%.

Note: Measuring machine: LCD-5100

6.2.2. Normally White Type (Positive)

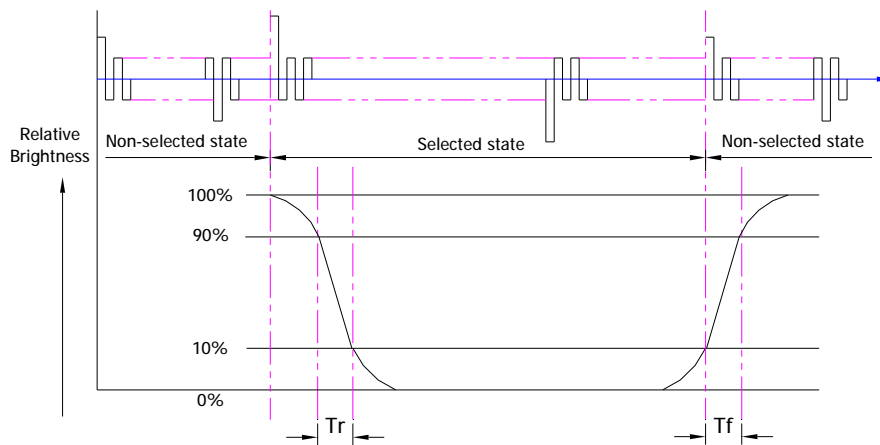

Tr is the time it takes to change from non-selected stage with relative luminance 90% to selected state with relative luminance 10%;

Tf is the time it takes to change from selected state with relative luminance 10% to non-selected state with relative luminance 90%;

Note: Measuring machine: LCD-5100 or EQUI

6.3. Definition of Contrast Ratio

Contrast is measured perpendicular to display surface in reflective and transmissive mode. The measurement condition is:

Measuring Equipment	Eldim or Equivalent
Measuring Point Diameter	3mm//1mm
Measuring Point Location	Active Area centre point
Test pattern	A: All Pixels white
	B: All Pixel black
Contrast setting	Maximum

Definitions: CR (Contrast) = Luminance of White Pixel / Luminance of Black Pixel

6.4. Definition of Viewing Angles

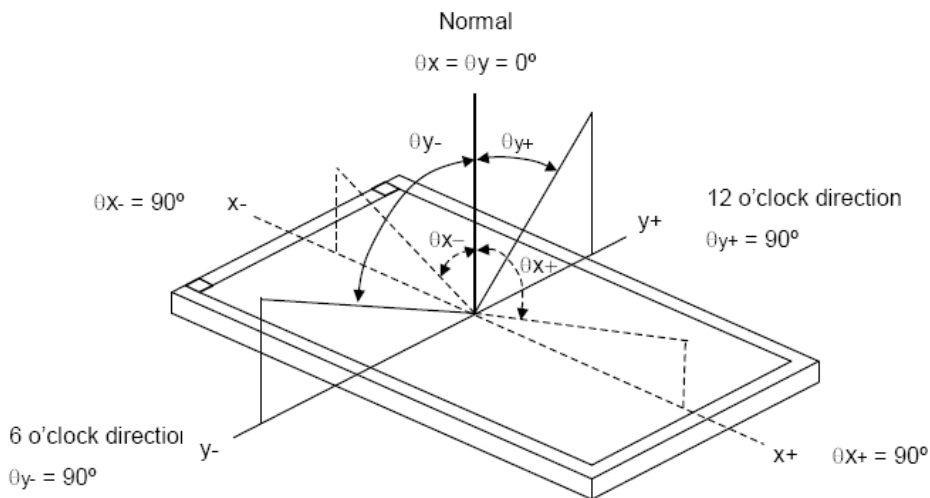

Measuring machine: LCD-5100 or EQUI

6.5. Definition of Color Appearance

R,G,B and W are defined by (x, y) on the IE chromaticity diagram

NTSC=area of RGB triangle/area of NTSC triangleX100%

Measuring picture: Red, Green, Blue and White (Measuring machine: BM-7)

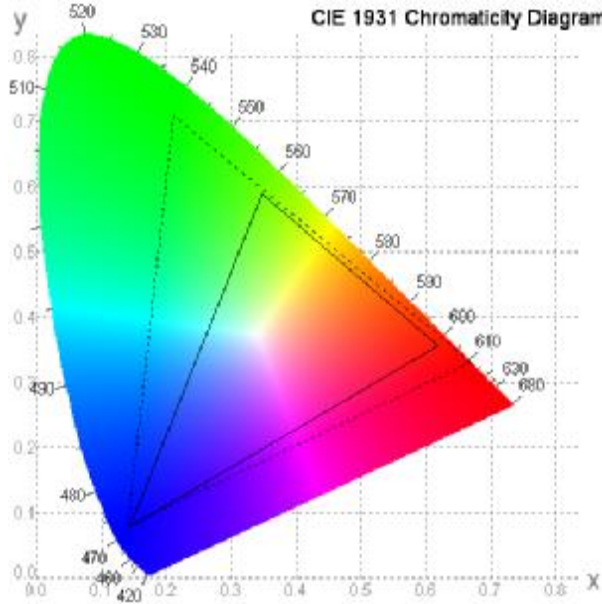

6.6. Definition of Surface Luminance, Uniformity and Transmittance

Using the transmissive mode measurement approach, measure the white screen luminance of the display panel and backlight.

6.6.1. Surface Luminance: $L_v = \text{average} (L_{P1}:L_{P9})$

6.6.2. Uniformity = $\text{Minimal} (L_{P1}:L_{P9}) / \text{Maximal} (L_{P1}:L_{P9}) * 100\%$

6.6.3. Transmittance = $L_v \text{ on LCD} / L_v \text{ on Backlight} * 100\%$

Note: Measuring machine: BM-7

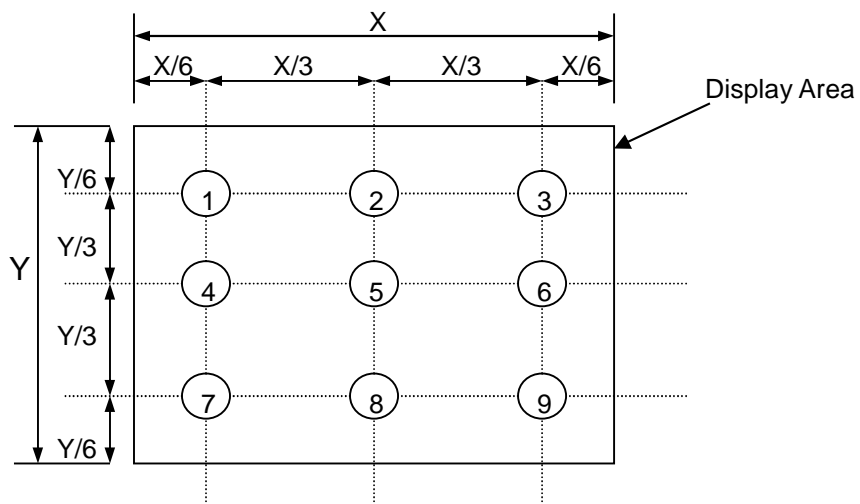

7. Block Diagram and Power Supply

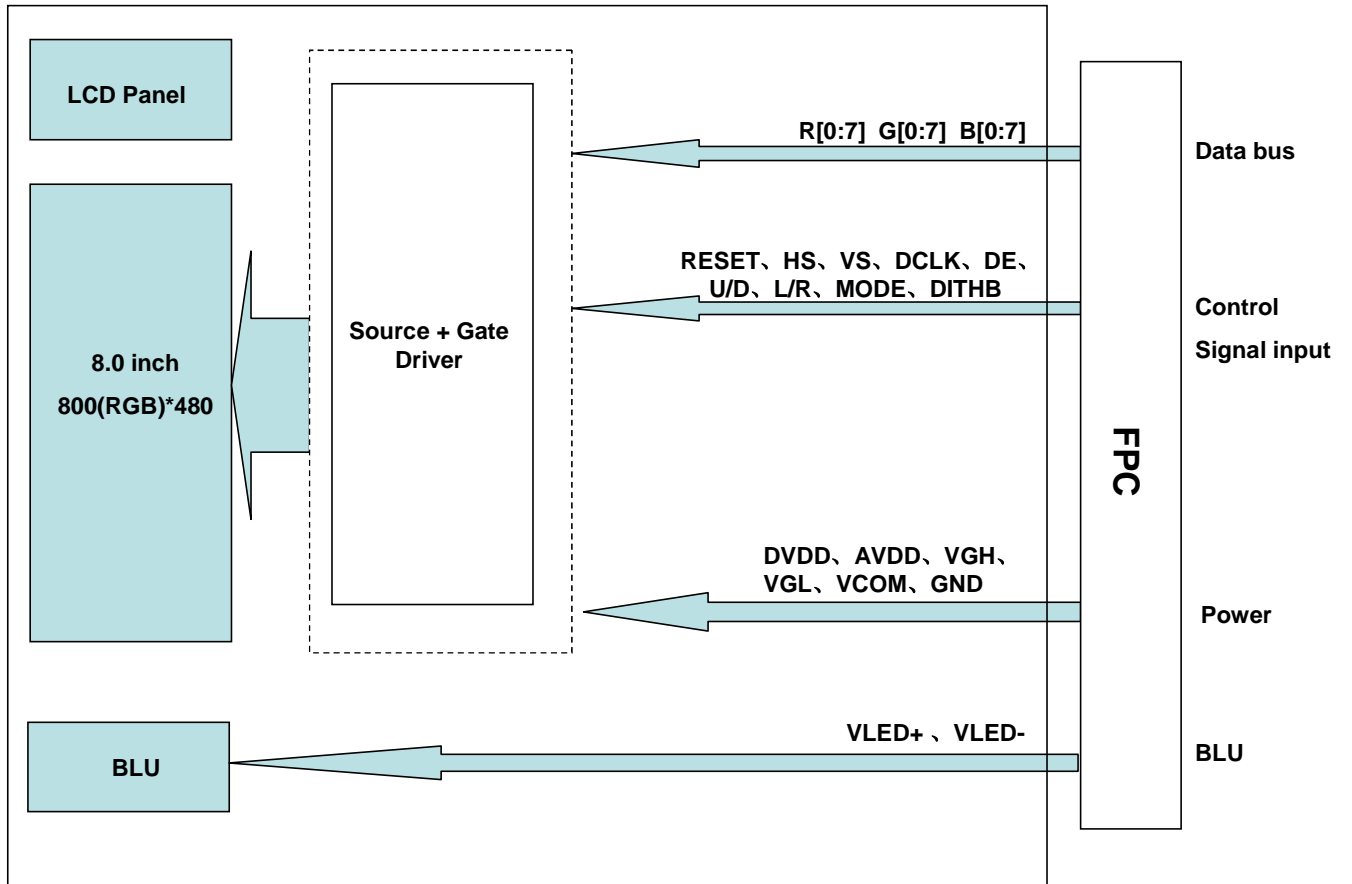

8. Interface Pins Definition

No.	Symbol	Function	Remark
1	VLED+	Led anode	
2	VLED+	Led anode	
3	VLED-	Led cathode	
4	VLED-	Led cathode	
5	GND	Ground	
6	VCOM	Common voltage input	
7	DVDD	Digital power supply	
8	MODE	DE/SYNC mode select. H:DE mode, L:SYNC mode	Note1
9	DE	Data enable signal, active high to enable data	
10	VS	Vertical sync input, negative polarity	
11	HS	Horizontal sync input, negative polarity	
12	B7	Blue data (MSB)	
13	B6	Blue data	
14	B5	Blue data	
15	B4	Blue data	
16	B3	Blue data	
17	B2	Blue data	
18	B1	Blue data	Note2
19	B0	Blue data (LSB)	Note2
20	G7	Green data (MSB)	
21	G6	Green data	
22	G5	Green data.	
23	G4	Green data	
24	G3	Green data	
25	G2	Green data	
26	G1	Green data.	Note2
27	G0	Green data (LSB)	Note2
28	R7	Red data (MSB)	
29	R6	Red data	
30	R5	Red data	
31	R4	Red data	
32	R3	Red data	
33	R2	Red data	
34	R1	Red data	Note2
35	R0	Red data (LSB)	Note2
36	GND	Ground	
37	DCLK	Clock for input data	Note3
38	GND	Ground	
39	L/R	Source left or right sequence control	Note4,5
40	U/D	Gate up or down scan control	Note4,5
41	VGH	Positive power of TFT	

42	VGL	Negative power of TFT	
43	AVDD	Analog power supply	
44	RESET	Global reset pin	Note6
45	NC	No connection	
46	VCOM	Common voltage input	
47	DITHB	Dithering setting. H: 6bit resolution, L: 8bit resolution	Note7
48	GND	Ground	
49	NC	No connection	
50	NC	No connection	

Note1: DE/SYNC mode select. Normally pull high.

When select DE mode, MODE="1", VS and HS can pull high or be ground.

When select SYNC mode, MODE="0", DE can pull high or be ground.

Note2: When input 18 bits RGB data, the two low bits of R, G and B data must be grounded.

Note3: Data shall be latched at the falling edge of DCLK.

Note4: Selection of scanning mode.

Setting of scan control input		Scanning direction
U/D	L/R	
GND	DV _{DD}	Up to down, left to right
DV _{DD}	GND	Down to up, right to left
GND	GND	Up to down, right to left
DV _{DD}	DV _{DD}	Down to up, left to right

Note5: Definition of scanning direction.

Refer to the figure as below:

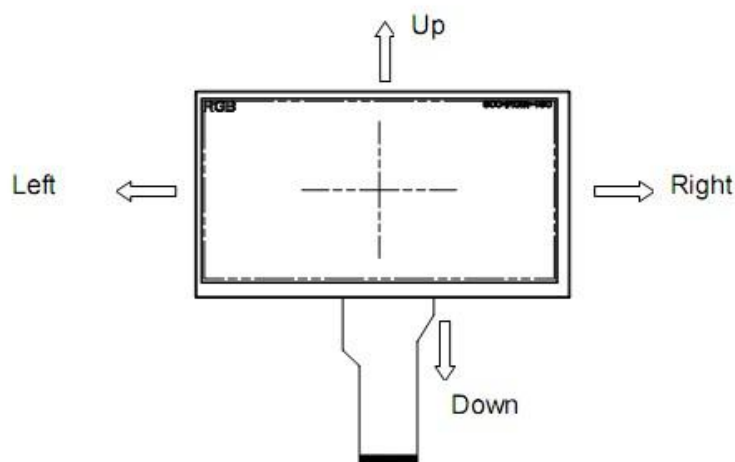

Note6: Global reset pin. Active low to enter reset state. Suggest to connect with an RC reset circuit for stability. Normally pull high.

Note 7: Dithering function enable control, normally pull high.

When DITHB="1", Disable internal dithering function,

When DITHB="0", Enable internal dithering function.

9. AC Characteristics

9.1. AC Electrical Characteristics

Item	Symbol	Values			Unit	Remark
		Min.	Typ.	Max.		
HS setup time	T_{hst}	8	-	-	ns	
HS hold time	T_{hhd}	8	-	-	ns	
VS setup time	T_{vst}	8	-	-	ns	
VS hold time	T_{vhd}	8	-	-	ns	
Data setup time	T_{dsu}	8	-	-	ns	
Data hole time	T_{dhd}	8	-	-	ns	
DE setup time	T_{esu}	8	-	-	ns	
DE hole time	T_{ehd}	8	-	-	ns	
DV _{DD} Power On Slew rate	T_{POR}	-	-	20	ms	From 0 to 90% DV _{DD}
RESET pulse width	T_{Rst}	1	-	-	ms	
DCLK cycle time	T_{coh}	20	-	-	ns	
DCLK pulse duty	T_{cwh}	40	50	60	%	

9.2. Data Input Format



Horizontal input timing diagram

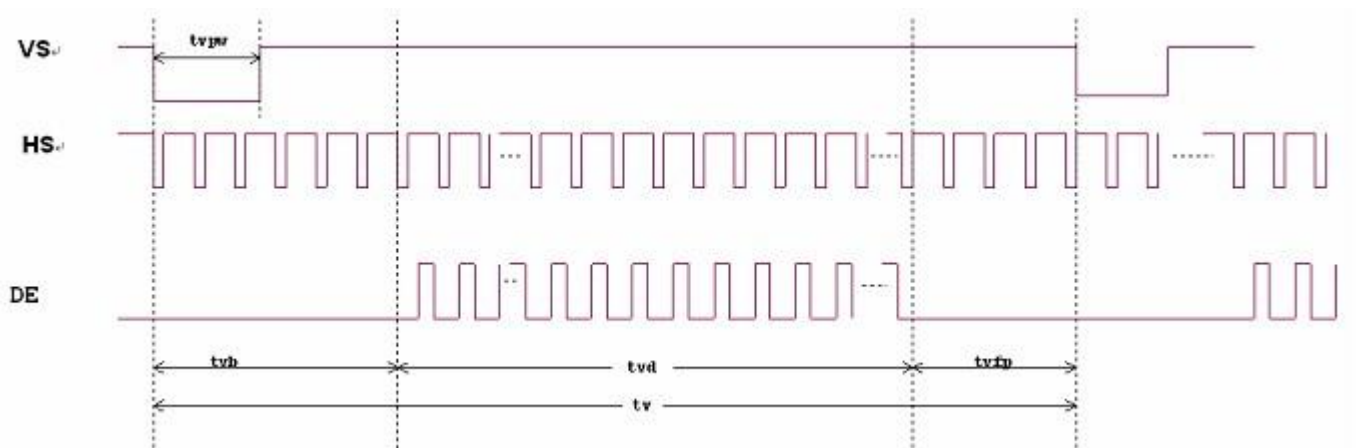

Vertical input timing diagram

9.3. Timing

Item	Symbol	Values			Unit	Remark
		Min.	Typ.	Max.		
Horizontal Display Area	thd	-	800	-	DCLK	
DCLK Frequency	fclk	26.4	33.3	46.8	MHz	
One Horizontal Line	th	862	1056	1200	DCLK	
HS pulse width	thpw	1	-	40	DCLK	
HS Blanking	thb	46	46	46	DCLK	
HS Front Porch	thfp	16	210	354	DCLK	

Item	Symbol	Values			Unit	Remark
		Min.	Typ.	Max.		
Vertical Display Area	tvd	-	480	-	TH	
VS period time	tv	510	525	650	TH	
VS pulse width	tvpw	1	-	20	TH	
VS Blanking	tvb	23	23	23	TH	
VS Front Porch	tvfp	7	22	147	TH	

9.4. Power Sequence

9.4.1 Power on:

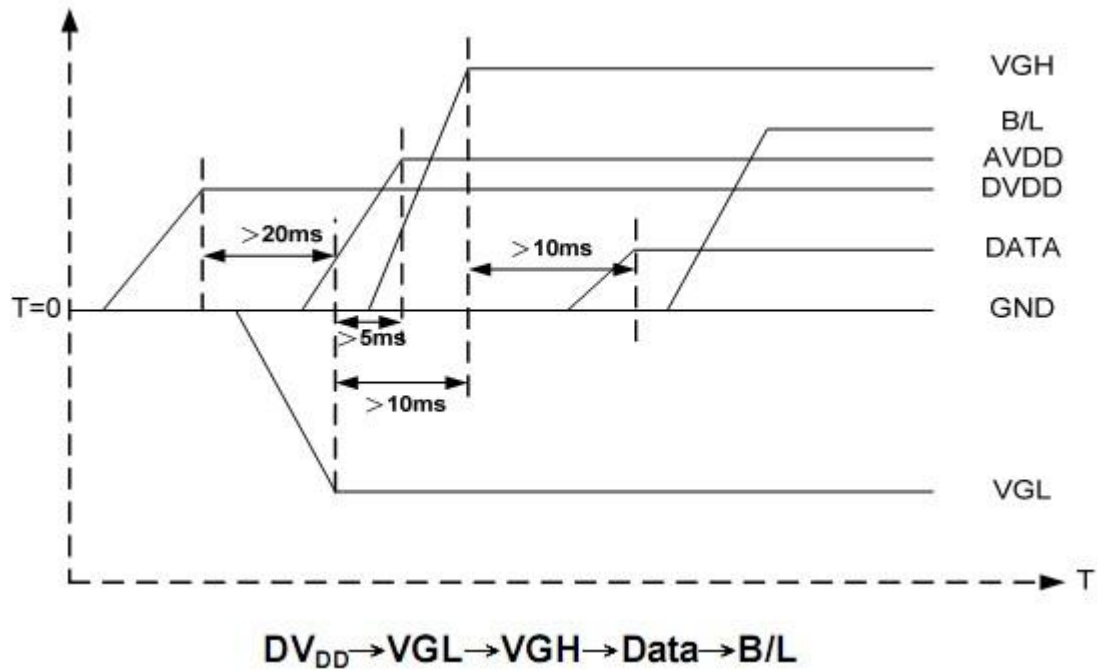

9.4.1 Power off:

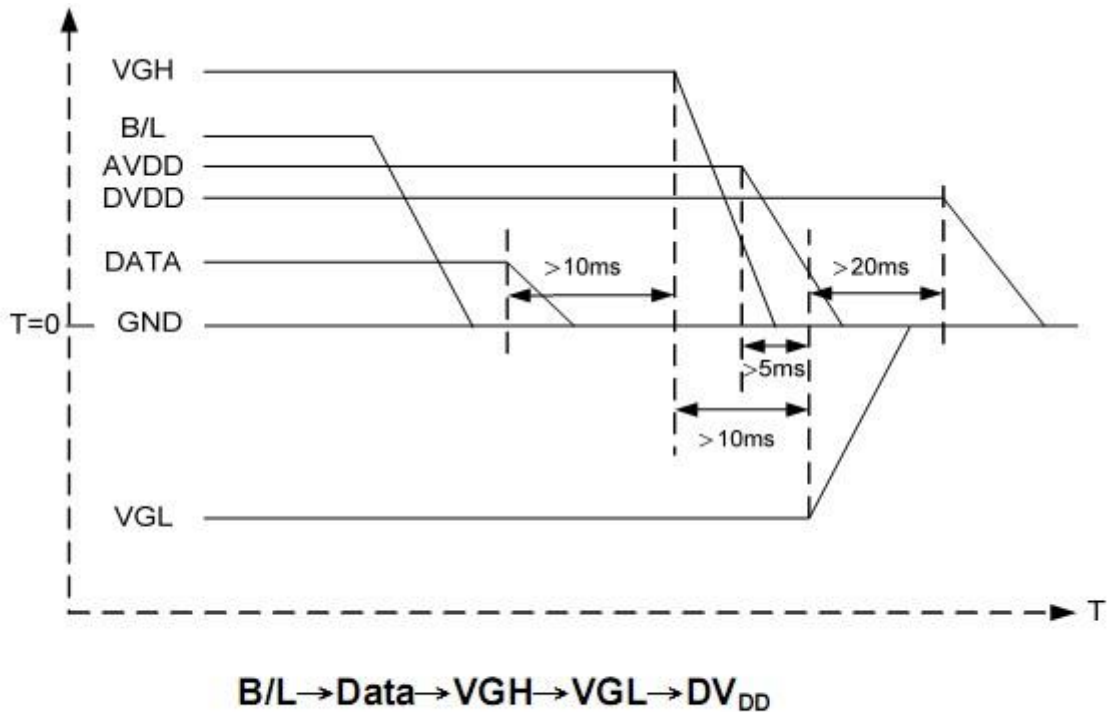

Note: Data include R0~R7, B0~B7, GO~G7, U/D, L/R, DCLK, HS, VS, DE.

10. Quality Assurance

10.1 Purpose

This standard for Quality Assurance assures the quality of LCD module products supplied to customer.

10.2 Standard for Quality Test

10.2.1 Sampling Plan:

ANSI / ASQC Z1.4-1993.

Single sampling, normal inspection.

10.2.2 Sampling Criteria:

Visual inspection: AQL 1.5%

Electrical functional: AQL 0.65%.

10.2.3 Reliability Test:

Detailed requirement refer to Reliability Test Specification.

10.3 Nonconforming Analysis & Disposition

10.3.1 Nonconforming analysis:

10.3.1.1 Customer should provide overall information of non-conforming sample for their complaints.

10.3.1.2 After receipt of detailed information from customer, the analysis of nonconforming parts usually should be finished in one week.

10.3.1.3 If cannot finish the analysis on time, customer will be notified with the progress status.

10.3.2 Disposition of nonconforming:

10.3.2.1 Non-conforming product over PPM level will be replaced.

10.3.2.2 The cause of non-conformance will be analyzed. Corrective action will be discussed and implemented.

10.4 Agreement Items

Shall negotiate with customer if the following situation occurs:

10.4.1 There is any discrepancy in standard of quality assurance.

10.4.2 Additional requirement to be added in product specification.

10.4.3 Any other special problem.

10.5 Standard of the Product Visual Inspection

10.5.1 Appearance inspection:

10.5.1.1 The inspection must be under illumination about 1000 – 1500 lx, and the distance of view must be at 30cm ± 2cm.

10.5.1.2 The viewing angle should be 45° from the vertical line without reflection light or follows customer's viewing angle specifications.

10.5.1.3 Definition of area: A Zone: Active Area, B Zone: Viewing Area,

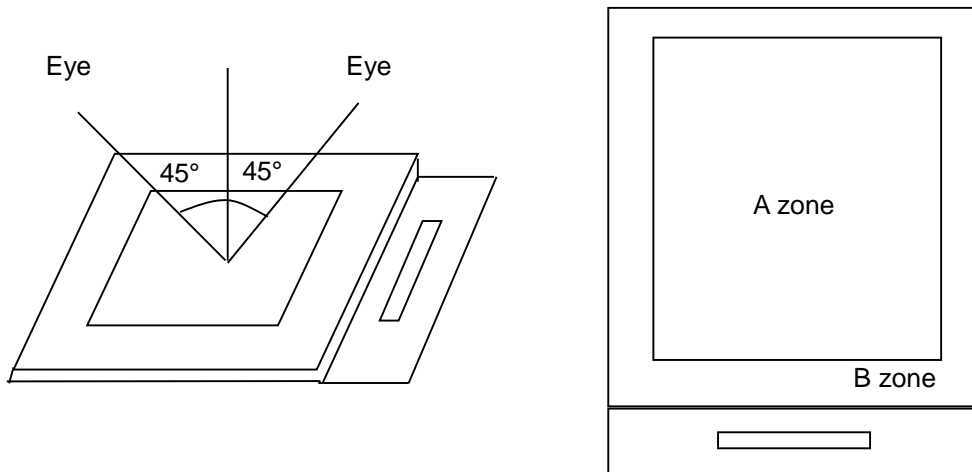

10.5.2 Basic principle:

10.5.2.1 A set of sample to indicate the limit of acceptable quality level must be discussed by both us and customer when there is any dispute happened.

10.5.2.2 New item must be added on time when it is necessary.

10.6 Inspection Specification

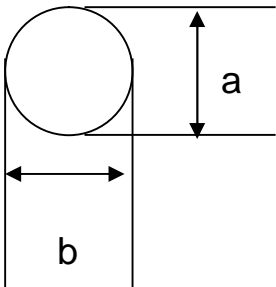
No.	Item	Criteria (Unit: mm)												
01	Black / White spot Foreign material (Round type) Pinholes Stain Particles inside cell. (Minor defect)	 $\phi = (a + b) / 2$ Distance between 2 defects should more than 5mm apart. <table border="1" data-bbox="898 1361 1401 1579"> <thead> <tr> <th>Size</th> <th>Area</th> <th>Acc. Qty</th> </tr> </thead> <tbody> <tr> <td>$\phi \leq 0.20$</td> <td></td> <td>Ignore</td> </tr> <tr> <td>$0.20 < \phi \leq 0.50$</td> <td></td> <td>$N \leq 3$</td> </tr> <tr> <td>$0.50 < \phi$</td> <td></td> <td>0</td> </tr> </tbody> </table>	Size	Area	Acc. Qty	$\phi \leq 0.20$		Ignore	$0.20 < \phi \leq 0.50$		$N \leq 3$	$0.50 < \phi$		0
Size	Area	Acc. Qty												
$\phi \leq 0.20$		Ignore												
$0.20 < \phi \leq 0.50$		$N \leq 3$												
$0.50 < \phi$		0												

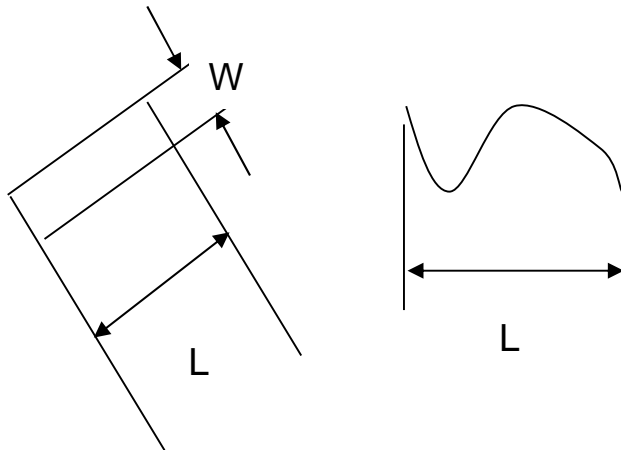
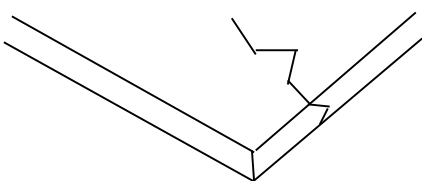
02	Electrical Defect (Minor defect)	<table border="1"> <tr> <td rowspan="2">Bright dot</td> <td>Display Area</td> <td>Total</td> <td rowspan="4">Note1</td> </tr> <tr> <td>$N \leq 2$</td> <td>$N \leq 2$</td> </tr> <tr> <td>Dark dot</td> <td>$N \leq 4$</td> <td>$N \leq 4$</td> </tr> <tr> <td>Total dot</td> <td>$N \leq 4$</td> <td>$N \leq 4$</td> </tr> </table>	Bright dot	Display Area	Total	Note1	$N \leq 2$	$N \leq 2$	Dark dot	$N \leq 4$	$N \leq 4$	Total dot	$N \leq 4$	$N \leq 4$	
		Bright dot		Display Area	Total		Note1								
$N \leq 2$	$N \leq 2$														
Dark dot	$N \leq 4$	$N \leq 4$													
Total dot	$N \leq 4$	$N \leq 4$													
<p>Remark: 1. Bright dot caused by scratch and foreign object accords to item 1.</p>															
03	Black and White line Scratch Foreign material (Line type) (Minor defect)														
		<table border="1"> <thead> <tr> <th>Length</th> <th>Width</th> <th>Acc. Qty</th> </tr> </thead> <tbody> <tr> <td>/</td> <td>$W \leq 0.1$</td> <td>Ignore</td> </tr> <tr> <td>$L \leq 2.5$</td> <td>$0.1 < W \leq 0.2$</td> <td>3</td> </tr> <tr> <td>$L > 2.5$</td> <td>$0.2 < W$</td> <td>0</td> </tr> <tr> <td colspan="2">Total</td> <td>3</td> </tr> </tbody> </table>	Length	Width	Acc. Qty	/	$W \leq 0.1$	Ignore	$L \leq 2.5$	$0.1 < W \leq 0.2$	3	$L > 2.5$	$0.2 < W$	0	Total
Length	Width	Acc. Qty													
/	$W \leq 0.1$	Ignore													
$L \leq 2.5$	$0.1 < W \leq 0.2$	3													
$L > 2.5$	$0.2 < W$	0													
Total		3													
<p>Distance between 2 defects should more than 3mm apart. Scratches not viewable through the back of the display are acceptable.</p>															
04	Glass Crack (Minor defect)														
<p>Crack is potential to enlarge, any type is not allowed.</p>															

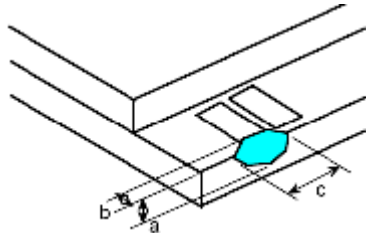
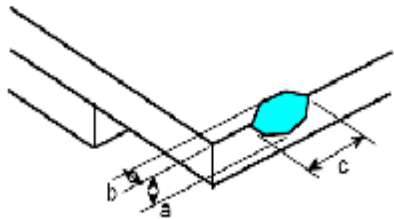
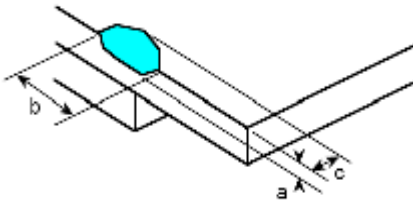
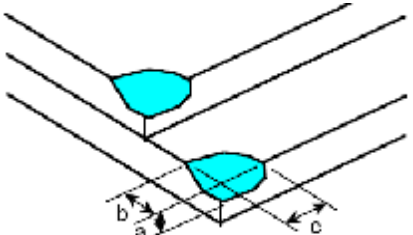
<p>05</p>	<p>Glass Chipping Pad Area: (Minor defect)</p> 	<table border="1"> <thead> <tr> <th>Length and Width</th> <th>Acc. Qty</th> </tr> </thead> <tbody> <tr> <td>$c > 3.0, b < 1.0$</td> <td>1</td> </tr> <tr> <td>$c < 3.0, b < 1.0$</td> <td>3</td> </tr> <tr> <td colspan="2" style="text-align: center;">$a < \text{Glass Thickness}$</td> </tr> </tbody> </table>	Length and Width	Acc. Qty	$c > 3.0, b < 1.0$	1	$c < 3.0, b < 1.0$	3	$a < \text{Glass Thickness}$			
Length and Width	Acc. Qty											
$c > 3.0, b < 1.0$	1											
$c < 3.0, b < 1.0$	3											
$a < \text{Glass Thickness}$												
<p>06</p>	<p>Glass Chipping Rear of Pad Area: (Minor defect)</p> 	<table border="1"> <thead> <tr> <th>Length and Width</th> <th>Acc. Qty</th> </tr> </thead> <tbody> <tr> <td>$c > 3.0, b < 1.0$</td> <td>1</td> </tr> <tr> <td>$c < 3.0, b < 1.0$</td> <td>2</td> </tr> <tr> <td>$c < 3.0, b < 0.5$</td> <td>4</td> </tr> <tr> <td colspan="2" style="text-align: center;">$a < \text{Glass Thickness}$</td> </tr> </tbody> </table>	Length and Width	Acc. Qty	$c > 3.0, b < 1.0$	1	$c < 3.0, b < 1.0$	2	$c < 3.0, b < 0.5$	4	$a < \text{Glass Thickness}$	
Length and Width	Acc. Qty											
$c > 3.0, b < 1.0$	1											
$c < 3.0, b < 1.0$	2											
$c < 3.0, b < 0.5$	4											
$a < \text{Glass Thickness}$												
<p>07</p>	<p>Glass Chipping Except Pad Area: (Minor defect)</p> 	<table border="1"> <thead> <tr> <th>Length and Width</th> <th>Acc. Qty</th> </tr> </thead> <tbody> <tr> <td>$c > 3.0, b < 1.0$</td> <td>1</td> </tr> <tr> <td>$c < 3.0, b < 1.0$</td> <td>2</td> </tr> <tr> <td>$c < 3.0, b < 0.5$</td> <td>4</td> </tr> <tr> <td colspan="2" style="text-align: center;">$a < \text{Glass Thickness}$</td> </tr> </tbody> </table>	Length and Width	Acc. Qty	$c > 3.0, b < 1.0$	1	$c < 3.0, b < 1.0$	2	$c < 3.0, b < 0.5$	4	$a < \text{Glass Thickness}$	
Length and Width	Acc. Qty											
$c > 3.0, b < 1.0$	1											
$c < 3.0, b < 1.0$	2											
$c < 3.0, b < 0.5$	4											
$a < \text{Glass Thickness}$												
<p>08</p>	<p>Glass Corner Chipping: (Minor defect)</p> 	<table border="1"> <thead> <tr> <th>Length and Width</th> <th>Acc. Qty</th> </tr> </thead> <tbody> <tr> <td>$c < 3.0, b < 3.0$</td> <td>Ignore</td> </tr> <tr> <td colspan="2" style="text-align: center;">$a < \text{Glass Thickness}$</td> </tr> </tbody> </table>	Length and Width	Acc. Qty	$c < 3.0, b < 3.0$	Ignore	$a < \text{Glass Thickness}$					
Length and Width	Acc. Qty											
$c < 3.0, b < 3.0$	Ignore											
$a < \text{Glass Thickness}$												

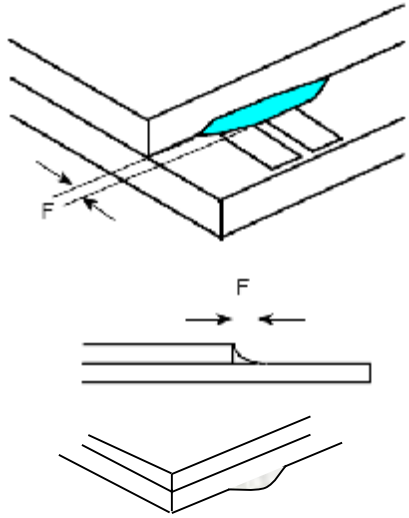
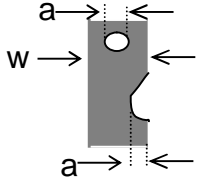
<p>09</p>	<p>Glass Burr: (Minor defect)</p> 	<table border="1" data-bbox="858 264 1332 353"> <thead> <tr> <th>Length</th> <th>Acc. Qty</th> </tr> </thead> <tbody> <tr> <td>$F < 1.0$</td> <td>Ignore</td> </tr> </tbody> </table> <p>Glass burr don't affect assemble and module dimension.</p>	Length	Acc. Qty	$F < 1.0$	Ignore				
Length	Acc. Qty									
$F < 1.0$	Ignore									
<p>10</p>	<p>FPC Defect: (Minor defect)</p> 	<p>10.1 Dent, pinhole width $a < w/3$. (w: circuitry width.) 10.2 Open circuit is unacceptable. 10.3 No oxidation, contamination and distortion.</p>								
<p>11</p>	<p>Bubble on Polarizer (Minor defect)</p>	<table border="1" data-bbox="735 1339 1206 1514"> <thead> <tr> <th>Diameter</th> <th>Acc. Qty</th> </tr> </thead> <tbody> <tr> <td>$\varphi \leq 0.30$</td> <td>Ignore</td> </tr> <tr> <td>$0.30 < \varphi \leq 0.50$</td> <td>$N \leq 2$</td> </tr> <tr> <td>$0.50 < \varphi$</td> <td>$N = 0$</td> </tr> </tbody> </table>	Diameter	Acc. Qty	$\varphi \leq 0.30$	Ignore	$0.30 < \varphi \leq 0.50$	$N \leq 2$	$0.50 < \varphi$	$N = 0$
Diameter	Acc. Qty									
$\varphi \leq 0.30$	Ignore									
$0.30 < \varphi \leq 0.50$	$N \leq 2$									
$0.50 < \varphi$	$N = 0$									
<p>12</p>	<p>Dent on Polarizer (Minor defect)</p>	<table border="1" data-bbox="735 1585 1206 1760"> <thead> <tr> <th>Diameter</th> <th>Acc. Qty</th> </tr> </thead> <tbody> <tr> <td>$\varphi \leq 0.25$</td> <td>Ignore</td> </tr> <tr> <td>$0.25 < \varphi \leq 0.50$</td> <td>$N \leq 4$</td> </tr> <tr> <td>$0.50 < \varphi$</td> <td>None</td> </tr> </tbody> </table>	Diameter	Acc. Qty	$\varphi \leq 0.25$	Ignore	$0.25 < \varphi \leq 0.50$	$N \leq 4$	$0.50 < \varphi$	None
Diameter	Acc. Qty									
$\varphi \leq 0.25$	Ignore									
$0.25 < \varphi \leq 0.50$	$N \leq 4$									
$0.50 < \varphi$	None									
<p>13</p>	<p>Bezel</p>	<p>13.1 No rust, distortion on the Bezel. 13.2 No visible fingerprints, stains or other contamination.</p>								

14	Touch Panel	<p>D: Diameter W: width L: length</p> <p>14.1 Spot: $D < 0.25$ is acceptable $0.25 \leq D \leq 0.4$</p> <p>2dots are acceptable and the distance between defects should more than 10 mm.</p> <p>$D > 0.4$ is unacceptable</p> <p>14.2 Dent: $D > 0.40$ is unacceptable</p> <p>14.3 Scratch: $W \leq 0.03$, $L \leq 10$ is acceptable, $0.03 < W \leq 0.10$, $L \leq 10$ is acceptable</p> <p>Distance between 2 defects should more than 10 mm. $W > 0.10$ is unacceptable.</p>
15	PCB	<p>15.1 No distortion or contamination on PCB terminals.</p> <p>15.2 All components on PCB must same as documented on the BOM/component layout.</p> <p>15.3 Follow IPC-A-600F.</p>
16	Soldering	Follow IPC-A-610C standard
17	Electrical Defect (Major defect)	<p>The below defects must be rejected.</p> <p>17.1 Missing vertical / horizontal segment,</p> <p>17.2 Abnormal Display.</p> <p>17.3 No function or no display.</p> <p>17.4 Current exceeds product specifications.</p> <p>17.5 LCD viewing angle defect.</p> <p>17.6 No Backlight.</p> <p>17.7 Dark Backlight.</p> <p>17.8 Touch Panel no function.</p>

Remark: LCD Panel Broken shall be rejected. Defect out of LCD viewing area is acceptable.

10.7 Classification of Defects

10.7.1 Visual defects (Except no / wrong label) are treated as minor defect and electrical defect is major.

10.7.2 Two minor defects are equal to one major in lot sampling inspection.

10.8 Identification/marketing criteria

Any unit with illegible / wrong /double or no marking/ label shall be rejected.

10.9 Packing

10.9.1 There should be no damage of the outside carton box, each packaging box should have one identical label.

10.9.2 Modules inside package box should have compliant mark.

10.9.3 All direct package materials shall offer ESD protection

Note1: Bright dot is defined as the defective area of the dot is larger than 50% of one sub-pixel area.

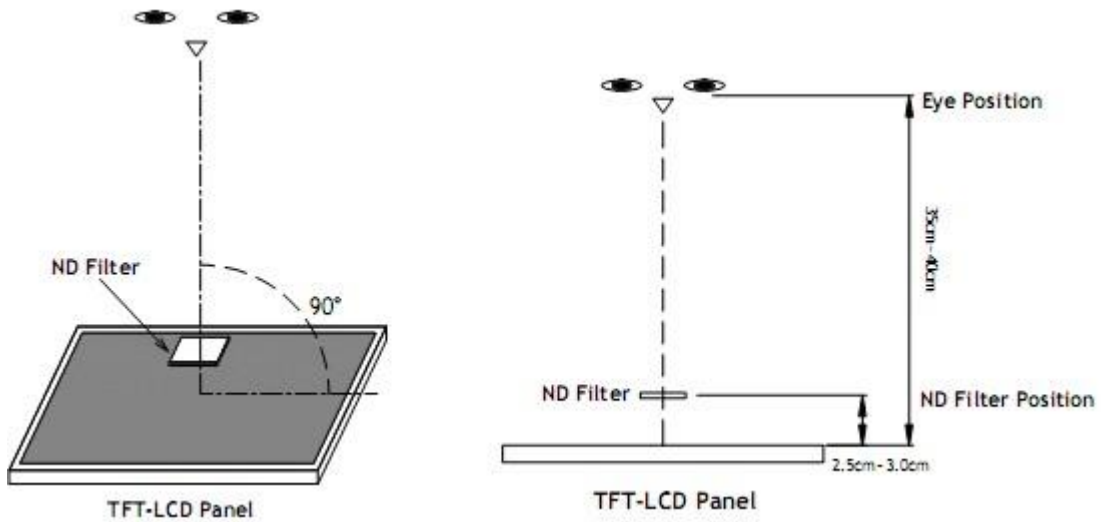

Bright dot: The bright dot size defect at black display pattern. It can be recognized by 2% transparency of filter when the distance between eyes and panel is 350mm ± 50mm.

Dark dot: Cyan, Magenta or Yellow dot size defect at white display pattern. It can be recognized by 5% transparency of filter when the distance between eyes and panel is 350mm ± 50mm.

11. Reliability Specification

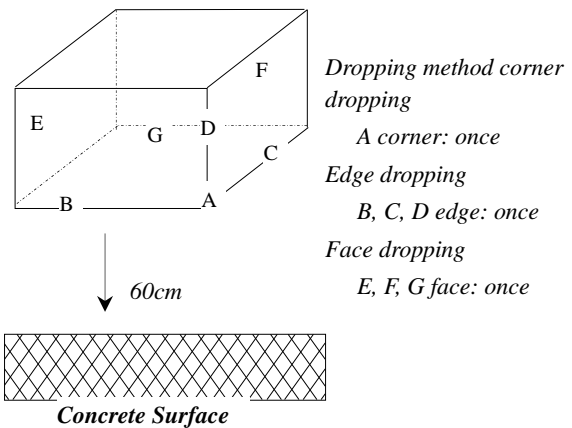
No	Item	Condition	Quantity
1	High Temperature Operating	85□, 96Hrs	5
2	Low Temperature Operating	-30□, 96Hrs	5
3	High Humidity	50□, 90%RH, 96Hrs	5
4	High Temperature Storage	85□, 96Hrs	5
5	Low Temperature Storage	-30□, 96Hrs	5
6	Thermal shock	-30□, 30min~85□, 30min, 10 cycles.	5
7	Packing vibration	Frequency range:10Hz~55Hz Amplitude of vibration:1.5mm Sweep time:12min X,Y,Z 2 hours for each direction.	5
8	Electrical Static Discharge	Air: ± 4KV 150pF/330Ω 5 times	5
		Contact: ± 2KV 150pF/330Ω 5 times	
9	Drop Test	<p>To be measured after dropping from 60cm high on the concrete surface in packing state.</p>  <p><i>Dropping method corner dropping</i> <i>A corner: once</i> <i>Edge dropping</i> <i>B, C, D edge: once</i> <i>Face dropping</i> <i>E, F, G face: once</i></p>	5

Note1. No deflection cosmetic and operational function allowable.

Note2. Total current Consumption should be below double of initial value

12. Precautions and Warranty

12.1 Safety

12.1.1 The liquid crystal in the LCD is poisonous. Do not put it in your mouth. If the liquid crystal touches your skin or clothes, wash it off immediately using soap and water.

12.1.2 Since the liquid crystal cells are made of glass, do not apply strong impact on them.
Handle with care.

12.2 Handling

12.2.1 Reverse and use within ratings in order to keep performance and prevent damage.

12.2.2 Do not wipe the polarizer with dry cloth, as it might cause scratch. If the surface of the LCD needs to be cleaned, wipe it swiftly with cotton or other soft cloth soaked with petroleum IPA, do not use other chemicals.

12.3 Storage

12.3.1 Do not store the LCD module beyond the specified temperature ranges.

12.4 Metal Pin (Apply to Products with Metal Pins)

12.4.1 Pins of LCD and Backlight

12.4.1.1 Solder tip can touch and press on the tip of Pin LEAD during the soldering

12.4.1.2 Recommended Soldering Conditions

Solder Type: Sn96.3~94-Ag3.3~4.3-Cu0.4~1.1

Maximum Solder Temperature: 370°C

Maximum Solder Time: 3s at the maximum temperature

Recommended Soldering Temp: 350±20°C

Typical Soldering Time: ≤3s

12.4.1.3 Solder Wetting

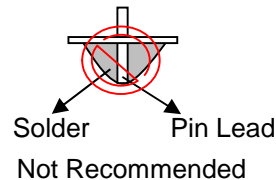
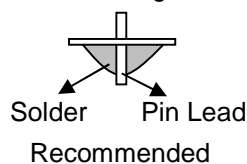

12.4.2 Pins of EL

12.4.2.1 Solder tip can touch and press on the tip of EL leads during soldering.

12.4.2.2. No Solder Paste on the soldering pad on the motherboard is recommended.

12.4.2.3 Recommended Soldering Conditions

Solder type: Nippon Alimit Leadfree SR-34, size 0.5mm

Recommended Solder Temperature: 270~290°C

Typical Soldering Time: ≤2s

Minimum solder distance from EL lamp (body):2.0mm

12.4.2.4 No horizontal press on the EL leads during soldering.

12.4.2.5 180° bend EL leads three times is not allowed.

12.4.2.6 Solder Wetting

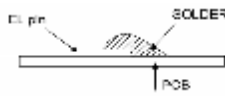

Recommended

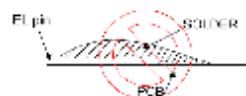

Not Recommended

12.4.2.7 The type of the solder iron:

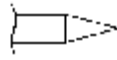

Recommended

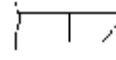

Not Recommended

12.4.2.8 Solder Pad

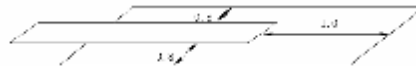

12.5 Operation

- 12.5.1 Do not drive LCD with DC voltage
- 12.5.2 Response time will increase below lower temperature
- 12.5.3 Display may change color with different temperature
- 12.5.4 Mechanical disturbance during operation, such as pressing on the display area, may cause the segments to appear “fractured”.

12.6 Static Electricity

- 12.6.1 CMOS LSIs are equipped in this unit, so care must be taken to avoid the electro-static charge, by ground human body, etc.
- 12.6.2 The normal static prevention measures should be observed for work clothes and benches.
- 12.6.3 The module should be kept into anti-static bags or other containers resistant to static for storage.

12.7 Limited Warranty

- 12.7.1 Our warranty liability is limited to repair and/or replacement. We will not be responsible for any consequential loss.
- 12.7.2 If possible, we suggest customer to use up all modules in six months. If the module storage time over twelve months, we suggest that recheck it before the module be used.

13. Packaging

t.b.d.

14. Outline Drawing

Pin assignment		NO	Symbol	NO	Symbol
1	VLED+	26	G1		
2	VLED+	27	G0		
3	VLED-	28	R7		
4	VLED-	29	R6		
5	GND	30	R5		
6	VCOM	31	R4		
7	DVDD	32	R3		
8	MODE	33	R2		
9	DE	34	R1		
10	VS	35	R0		
11	HS	36	GND		
12	B7	37	DCLK		
13	B6	38	GND		
14	B5	39	LR		
15	B4	40	UD		
16	B3	41	VGH		
17	B2	42	VGL		
18	B1	43	AVDD		
19	B0	44	RESET		
20	G7	45	NC		
21	G6	46	VCOM		
22	G5	47	DITHB		
23	G4	48	GND		
24	G3	49	NC		
25	G2	50	NC		

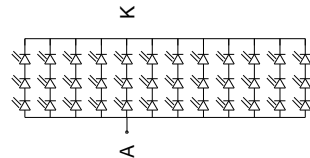
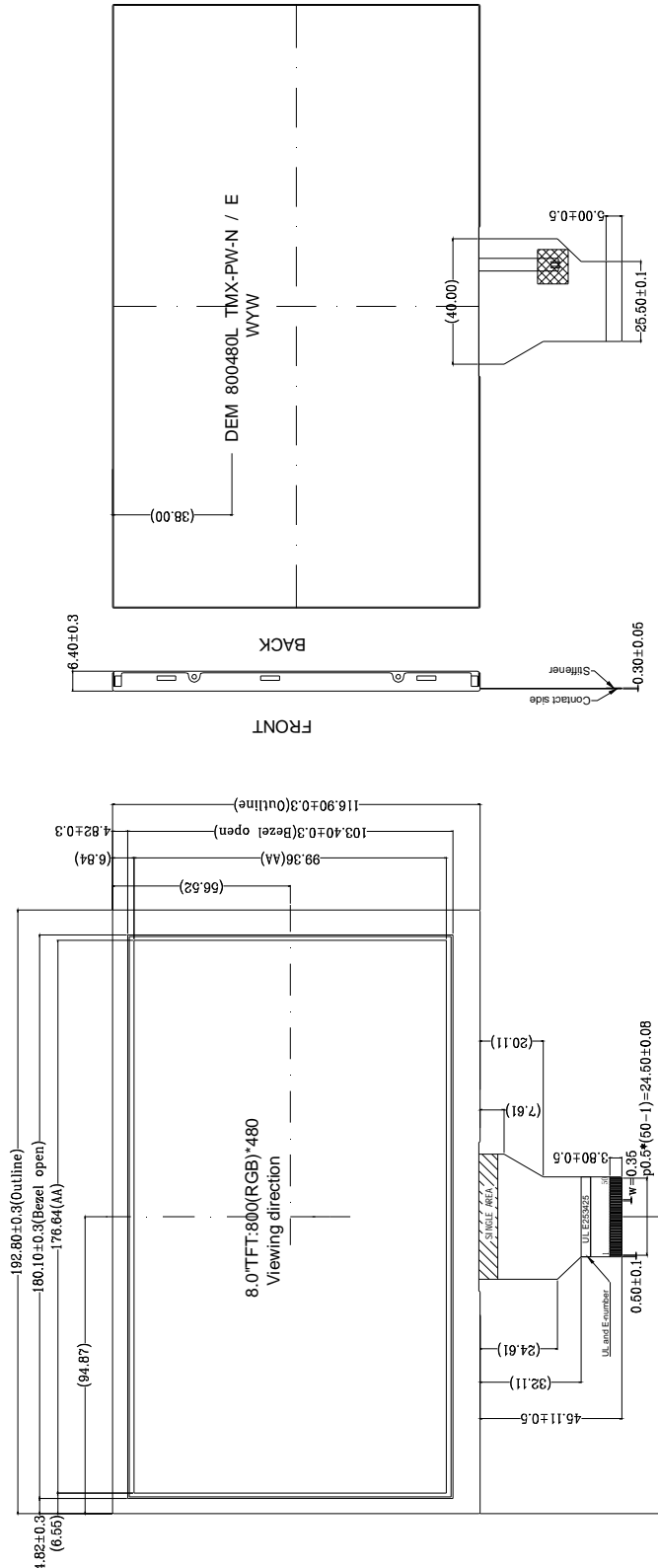

CIRCUIT DIAGRAM

- NOTES:
1. Display type: 8.0" TFT/Anti-glare
 2. Viewing direction: 12 0' CLOCK
 3. Gray scale inversion direction: 6 0' CLOCK
 4. Polarizer mode: Transmissive/Normal white
 5. Operation temperature: -30 ° C ~ +85 ° C
 6. Storage temperature: -30 ° C ~ +85 ° C
 7. Power supply voltage: 3.3V
 8. Backlight : White(36 LED)/9.6V/240(TYPE)mA
 9. ROHS must be complied
 10. Unspecification tolerance are ±0.3mm