

Display Elektronik GmbH

DATA SHEET

TFT- MODULE

DEM 640480B VMH-PW-N

4,0" TFT

Product Specification

Ver.: 2

24.06.2017

Revision History

Revision	Date	Originator	Detail	Remarks
0	09.01.2017	ZFY	Initial Release	-
1	09.03.2017	ZFY	Add weight Add chromaticity Modify IC	P4 P6 All Pages
2	24.06.2017	ZFY	Modify PIN Definition	P9 / P10 / P27

Table of Contents

No.	Item	Page
1.	General Description	4
2.	Module Parameter	4
3.	Absolute Maximum Ratings	4
4.	DC Characteristics	5
5.	Backlight Characteristic	5
5.1.	Backlight Characteristic	5
5.2.	Backlight Characteristic	5
6.	Optical Characteristics	6
6.1.	Optical Characteristics	6
6.2.	Definition of Response Time	6
6.3.	Definition of Contrast Ratio	7
6.4.	Definition of Viewing Angles	7
6.5.	Definition of Color Appearance	8
6.6.	Definition of Surface Luminance, Uniformity and Transmittance	8
7.	Block Diagram and Power Supply	9
8.	Interface Pins Definition	10
9.	AC Characteristics	11
9.1.	Serial interface characteristics	11
9.2.	MIPI Interface timing	12
10.	Reset timing characteristic	16
11.	Quality Assurance	17
11.1.	Purpose	17
11.2.	Standard for Quality Test	17
11.3.	Nonconforming Analysis & Disposition	17
11.4.	Agreement Items	17
11.5.	Standard of the Product Visual Inspection	18
11.6.	Inspection Specification	18
11.7.	Classification of Defects	22
11.8.	Identification/marketing criteria	22
11.9.	Packaging	22
12.	Reliability Specification	24
13.	Precautions and Warranty	25
13.1	Safety	25
13.2.	Handling	25
13.3.	Storage	25
13.4.	Metal Pin (Apply to Products with Metal Pins)	25
13.5.	Operation	26
13.6.	Static Electricity	26
13.7.	Limited Warranty	26
14.	Outline Drawing	27

1. General Description

The specification is a transmissive type color active matrix liquid crystal display (LCD) which uses amorphous thin film transistor (TFT) as switching devices. This product is composed of a TFT-LCD panel, driver Ics and a backlight unit.

2. Module Parameter

Features	Details	Unit
Display Size (Diagonal)	4.0"	-
LCD Type	IPS TFT	-
Display Mode	Transmissive / Normally black	-
Resolution	640 x RGB x 480	Pixels
View Direction	FULL VIEW	Best Image
Module Outline	89.30 x 73.06 x 2.90 (Note1)	mm
Active Area	82.56 x 61.92	mm
Pixel Size	0.129 x 0.129	mm
Pixel Arrangement	Stripe	-
Polarizer Surface Treatment	Glare	-
Display Colors	16.7 Million	-
Interface	MIPI DSI-Interface	-
With or without touch panel	Without	-
Driver IC	OTM1287A (Focaltech)	-
Operating Temperature	-20°C to +70°C	°C
Storage Temperature	-30°C to +80°C	°C
Weight	~ 40	g

Note 1: Exclusive hooks, posts, FFC/FPC tail etc.

3. Absolute Maximum Ratings

V_{SS}=0V, Ta=25°C

Item	Symbol	Min.	Max.	Unit
Supply Voltage	VDD	-0.3	4.5	V
Storage Temperature	T _{STG}	-30	+80	°C
Operating Temperature	T _{OP}	-20	+70	°C

Note 1: If Ta below 50°C, the maximal humidity is 90%RH, if Ta over 50°C, absolute humidity should be less than 60%RH.

Note 2: The response time will be extremely slow when the operating temperature is around -10°C, and the back ground will become darker at high temperature operating.

4. DC Characteristics

Item	Symbol	Min.	Typ.	Max.	Unit	
Supply Voltage	VDD	2.5	3.3	3.6	V	
Logic 0 Input Voltage	V _{IL}	0	-	550	mV	
Logic 1 Input Voltage	V _{IH}	880	-	LVDSVDD	mV	
Logic 0 Output Voltage	V _{OL}	-50	-	50	mV	
Logic 1 Output Voltage	V _{OH}	1.1	1.2	1.3	V	
Current Consumption All Black	Logic	I _{CC+ IIN}	-	(30)	-	mA
	Analog					

5. Backlight Characteristic

5.1. Backlight Characteristic

Item	Symbol	Condition	Min.	Typ.	Max.	Unit
Forward Voltage	V _F	T _a =25 °C, I _F =20mA/LED	14.0	16.0	17.0	V
Forward Current	I _F	T _a =25 °C, V _F =3.2V/LED	-	40	-	mA
Power Dissipation	P _D		-	640	-	mW
Uniformity	Avg		-	80	-	%
LED Lifetime (25°C)	-		20000	30000		Hrs
Drive Method	Constant Current					
LED Configuration	10 White LEDs (5 LEDs in one string and 2 groups in parallel)					

Note1: LED lifetime defined as follows: The final brightness is at 50% of original brightness.
 The environmental conducted under ambient air flow, at T_a=25±2 °C, 60%RH±5%, I_F=20mA

5.2. Backlight Characteristic

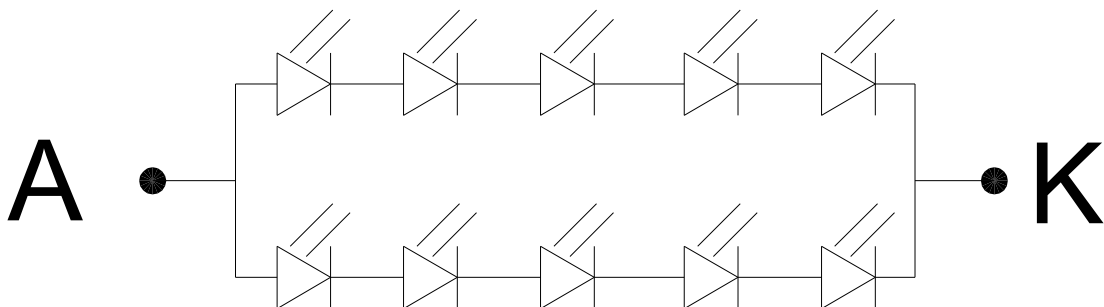

6. Optical Characteristics

6.1. Optical Characteristics

Ta=25°C, VDD=3.3V, TN LC+ Polarizer

	Item	Symbol	Condition	Specification			Unit	
				Min.	Typ.	Max.		
Backlight On (Transmissive Mode)	Luminance on TFT ($I_f=20\text{mA/LED}$)	Lv	Normally viewing angle $\theta_x = \phi_y = 0^\circ$	380	480	-	cd/m ²	
	Contrast Ratio(See 6.3)	CR		-	400	-		
	Response Time (See 6.2)	TR+TF		-	-	(16)	ms	
	Chromaticity Transmissive (See 6.5)	Red	XR	Center CR≥10	0.591	0.641	0.691	
			YR		0.304	0.354	0.404	
		Green	XG		0.256	0.306	0.356	
			YG		0.566	0.616	0.666	
		Blue	XB		0.095	0.145	0.195	
			YB		0.018	0.068	0.118	
	White	XW	0.273	0.323	0.373			
		YW	0.320	0.370	0.420			
Viewing Angle (See 6.4)	Horizontal	θ_{x+}	Center CR≥10		(80)	-	Deg.	
		θ_{x-}			(80)	-		
	Vertical	ϕ_{y+}			(80)	-		
		ϕ_{y-}			(80)	-		
NTSC Ratio(Gamut)				-	(50)	-	%	

6.2. Definition of Response Time

6.2.1. Normally Black Type (Negative)

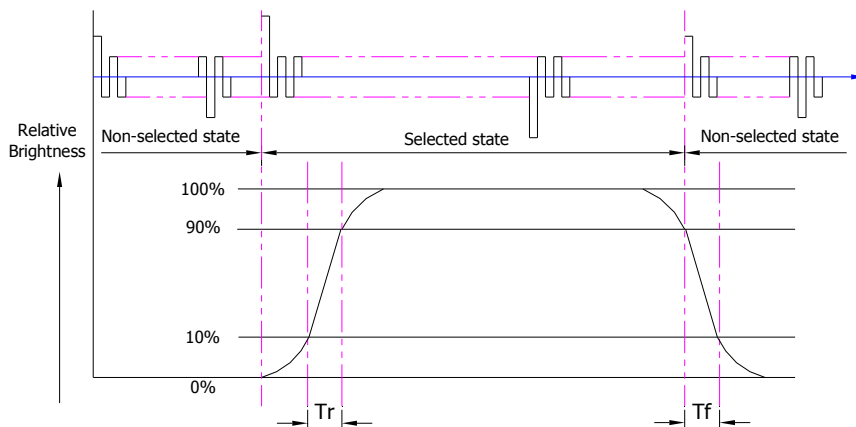

Tr is the time it takes to change from non-selected state with relative luminance 10% to selected state with relative luminance 90%;

Tf is the time it takes to change from selected state with relative luminance 90% to non-selected state with relative luminance 10%.

Note: Measuring machine: LCD-5100

6.2.2. Normally White Type (Positive)

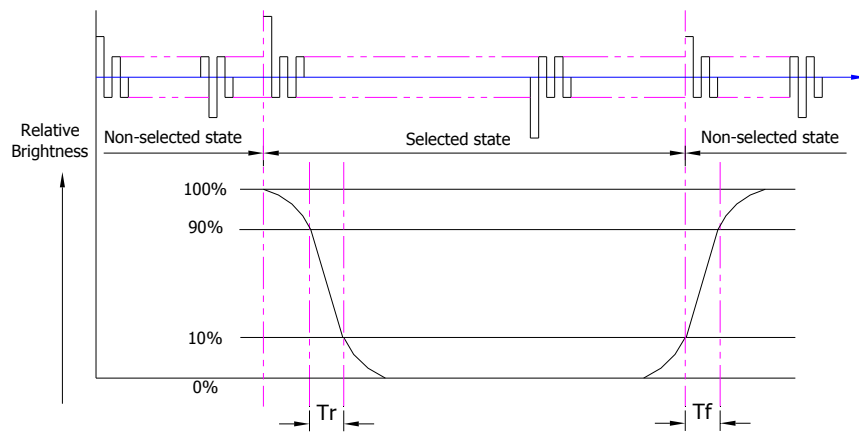

T_r is the time it takes to change from non-selected stage with relative luminance 90% to selected state with relative luminance 10%;

T_f is the time it takes to change from selected state with relative luminance 10% to non-selected state with relative luminance 90%;

Note: Measuring machine: LCD-5100 or EQUI

6.3. Definition of Contrast Ratio

Contrast is measured perpendicular to display surface in reflective and transmissive mode. The measurement condition is:

Measuring Equipment	Eldim or Equivalent
Measuring Point Diameter	3mm//1mm
Measuring Point Location	Active Area centre point
Test pattern	A: All Pixels white
	B: All Pixel black
Contrast setting	Maximum

Definitions: CR (Contrast) = Luminance of White Pixel / Luminance of Black Pixel

6.4. Definition of Viewing Angles

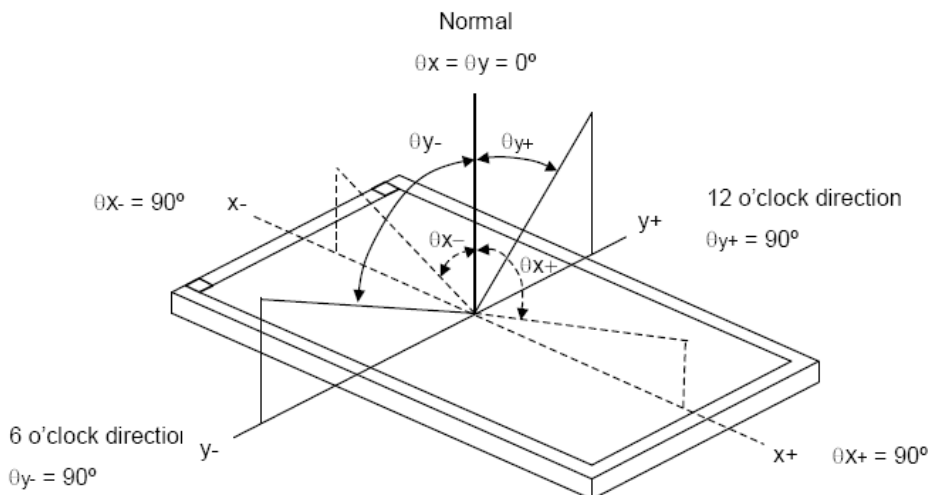

Measuring machine: LCD-5100 or EQUI

6.5. Definition of Color Appearance

R,G,B and W are defined by (x, y) on the IE chromaticity diagram

NTSC=area of RGB triangle/area of NTSC triangleX100%

Measuring picture: Red, Green, Blue and White (Measuring machine: BM-7)

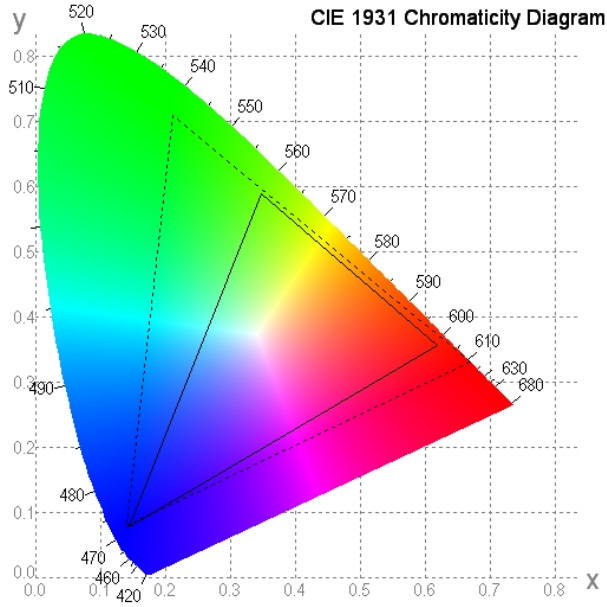

6.6. Definition of Surface Luminance, Uniformity and Transmittance

Using the transmissive mode measurement approach, measure the white screen luminance of the display panel and backlight.

6.6.1. Surface Luminance: $L_v = \text{average} (L_{P1}:L_{P9})$

6.6.2. Uniformity = $\text{Minimal} (L_{P1}:L_{P9}) / \text{Maximal} (L_{P1}:L_{P9}) * 100\%$

6.6.3. Transmittance = $L_v \text{ on LCD} / L_v \text{ on Backlight} * 100\%$

Note: Measuring machine: BM-7

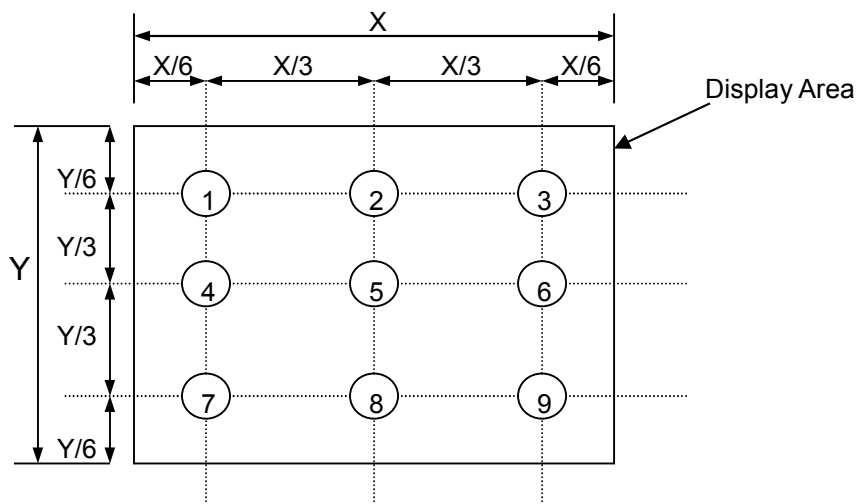

7. Block Diagram and Power Supply

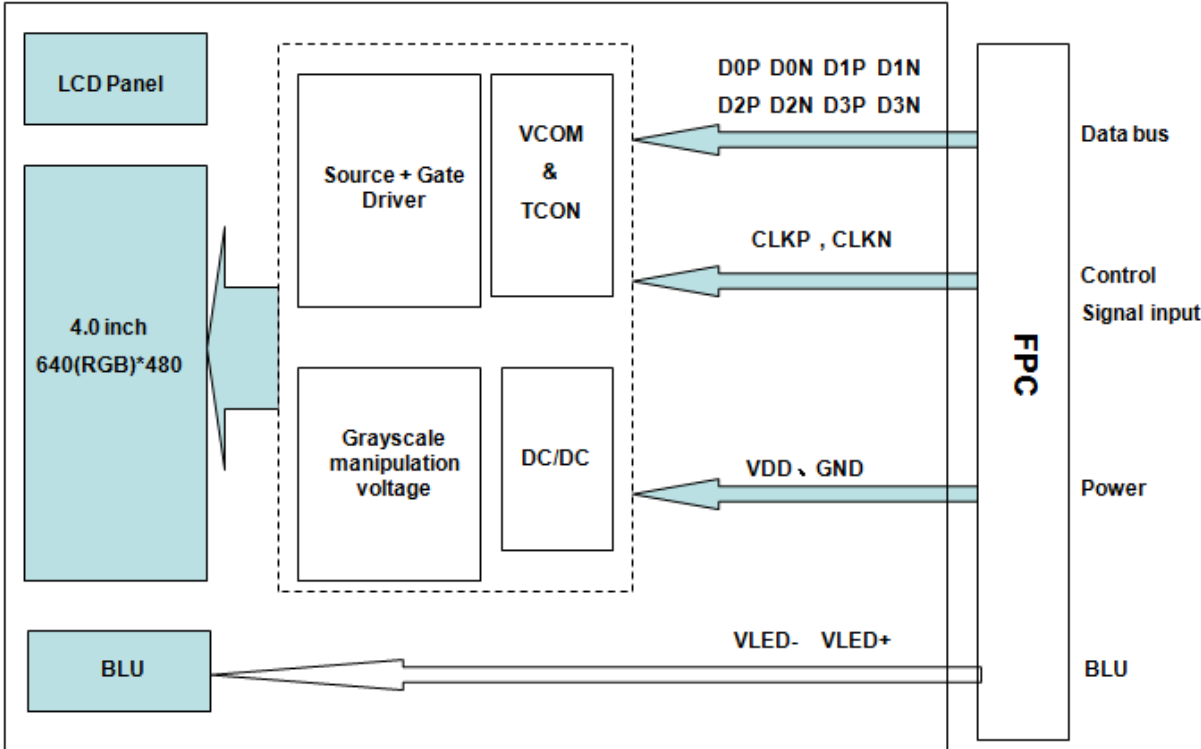

8. Interface Pins Definition

No.	Symbol	Function	Remark
1	VLED-	Led cathode	
2	VLED+	Led anode	
3	VDD	Power supply	
4	GND	Ground	
5	D0P	MIPI-DSI data Lane 0 positive-end input/output pin	
6	D0N	MIPI-DSI data Lane 0 negative-end input/output pin	
7	GND	Ground	
8	D1P	MIPI-DSI data Lane 1 positive-end input/output pin	
9	D1N	MIPI-DSI data Lane 1 negative-end input/output pin	
10	GND	Ground	
11	CLKP	MIPI-DSI clock Lane positive-end input pin	
12	CLKN	MIPI-DSI clock Lane negative-end input pin	
13	GND	Ground	
14	D2P	MIPI-DSI data Lane 2 positive-end input/output pin	
15	D2N	MIPI-DSI data Lane 2 negative-end input/output pin	
16	GND	Ground	
17	D3P	MIPI-DSI data Lane 3 positive-end input/output pin	
18	D3N	MIPI-DSI data Lane 3 negative-end input/output pin	
19	GND	Ground	
20	NC	Serial clock	
21	NC	Chip Select Signal	
22	NC	Serial data	
23	GND	Ground	
24 ~ 30	NC	No connection	

9. AC Characteristics

9.1. Serial interface characteristics

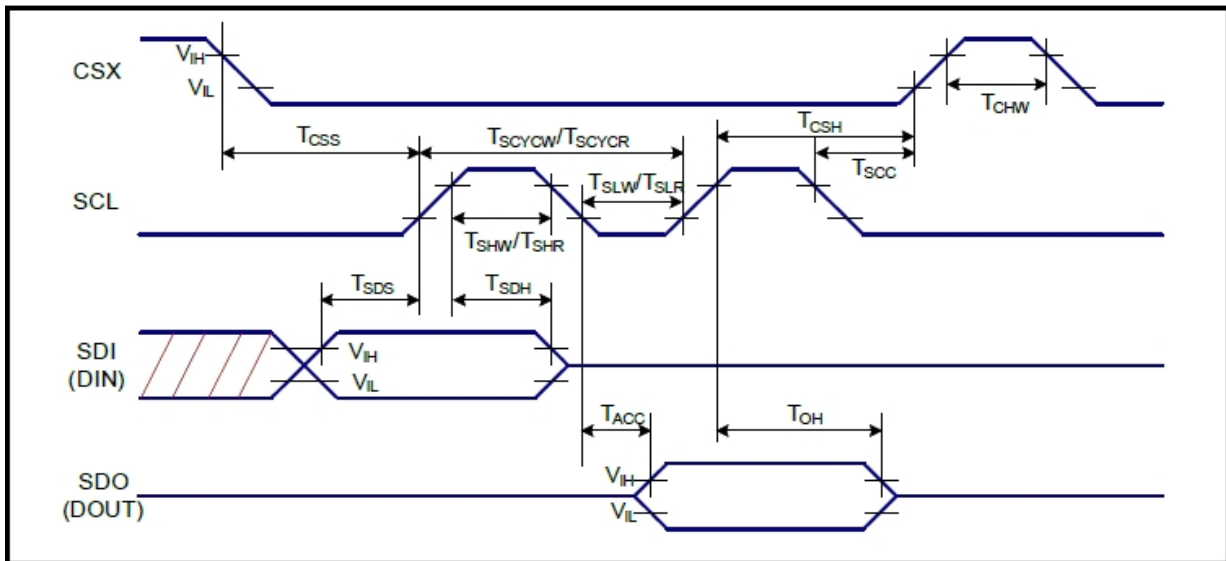

Signal	Symbol	Parameter	MIN	MAX	Unit	Description
CSX	T_{CSS}	Chip select setup time	15	-	ns	
	T_{CSH}	Chip select hold time	15	-	ns	
	T_{SCC}	Chip select setup time	20	-	ns	
	T_{CHW}	Chip select setup time	40	-	ns	
SCL	T_{SCYCW}	Serial clock cycle (Write)	66	-	ns	
	T_{SHW}	SCL "H" pulse width (Write)	10	-	ns	
	T_{SLW}	SCL "L" pulse width (Write)	10	-	ns	
	T_{SCYCR}	Serial clock cycle (Read)	150	-	ns	
	T_{SHR}	SCL "H" pulse width (Read)	60	-	ns	
	T_{SLR}	SCL "L" pulse width (Read)	60	-	ns	
SDA (DIN) (DOUT)	T_{SDS}	Data setup time	10	-	ns	
	T_{SDH}	Data hold time	10	-	ns	
	T_{ACC}	Access time	10	50	ns	For maximum $C_L=30pF$
	T_{OH}	Output disable time	15	50	ns	For minimum $C_L=8pF$

9.2. MIPI Interface timing

9.2.1 High-Speed Mode

Parameter	Symbol	Parameter	Specification			Unit
			MIN	TYP	MAX	
High Speed Mode						
DSI-CLK+/-	$2xU_{INST}$	Double UI instantaneous	2.22	-	25	ns
DSI-CLK+/-	U_{INSTA}, U_{INSTB}	UI instantaneous Halfs	1.11	-	12.5	ns
DSI-Dn+/-	t_{DS}	Data to clock setup time	0.15	-	-	UI
DSI-Dn+/-	t_{DH}	Data to clock hold time	0.15	-	-	UI
DSI-CLK+/-	t_{DRTCLK}	Differential rise time for clock	150	-	0.3UI	ps
DSI-Dn+/-	$t_{DRTDATA}$	Differential rise time for data	150	-	0.3UI	ps
DSI-CLK+/-	t_{DFTCLK}	Differential fall time for clock	150	-	0.3UI	ps
DSI-Dn+/-	$t_{DFTDATA}$	Differential fall time for data	150	-	0.3UI	ps

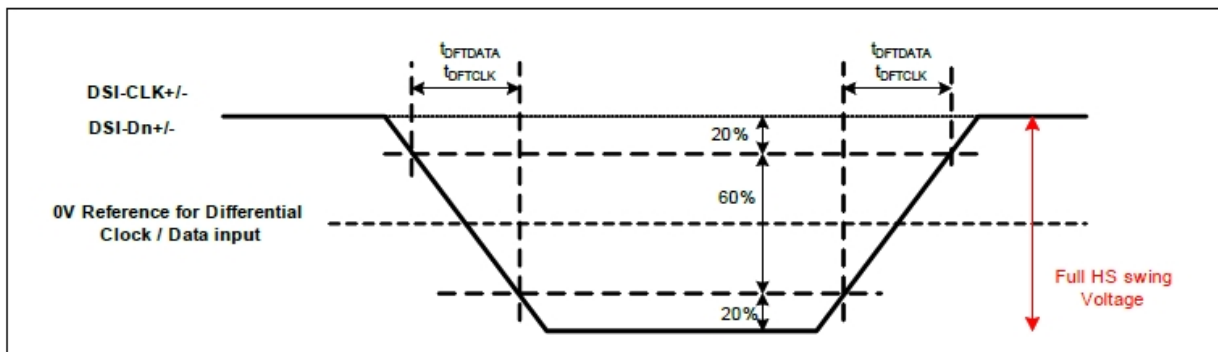
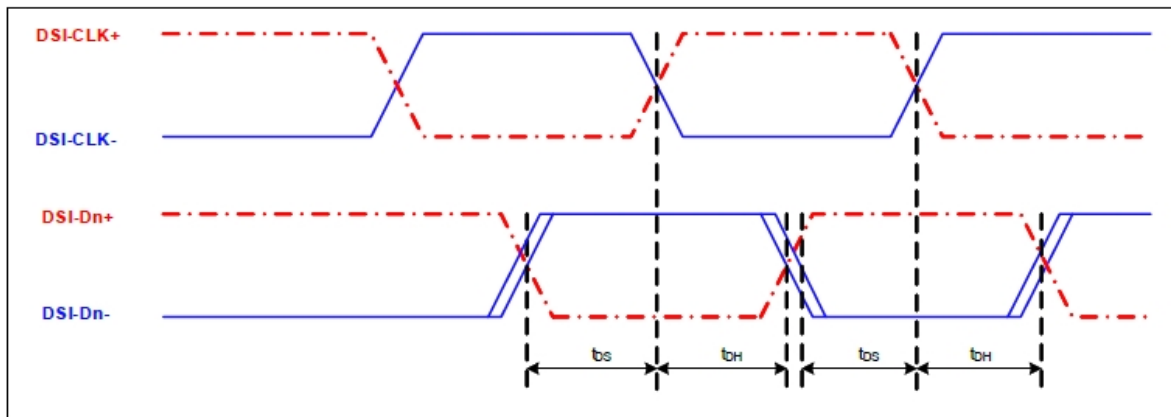
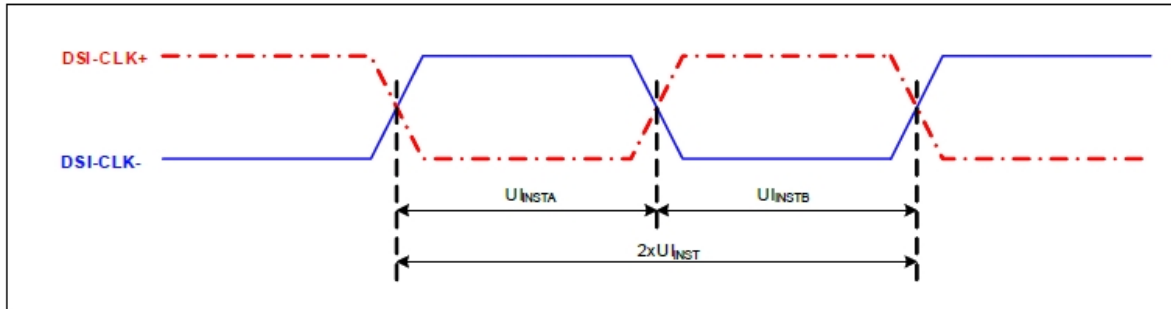

9.2.2 Low-Power Mode

Parameter	Symbol	Parameter	Specification			Unit
			MIN	TYP	MAX	
Low Power mode						
DSI-D0+/-	T_{LPXM}	Length of LP-00, LP-01, LP-10 or LP-11 periods MPU Display Module	50	-	-	ns
DSI-D0+/-	T_{LPXD}	Length of LP-00, LP-01, LP-10 or LP-11 periods Display Module MPU	58	-	-	ns
DSI-D0+/-	$T_{TA-SURED}$	Time-out before the MPU start driving	T_{LPXD}	-	$2XT_{LPXD}$	ns
DSI-D0+/-	$T_{TA-GETD}$	Time to drive LP-00 by display module	$5XT_{LPXD}$	-	-	ns
DSI-D0+/-	T_{TA-GOD}	Time to drive LP-00 after turnaround request - MPU	$4XT_{LPXD}$	-	-	ns
DSI-D0+/-	Ratio T_{LPX}	Ratio of T_{LPXM} / T_{LPXD} between MCU and display module	2/3	-	3/2	

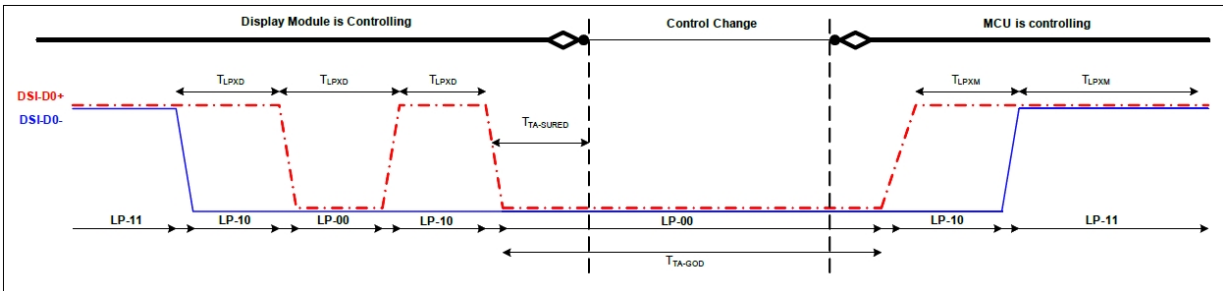
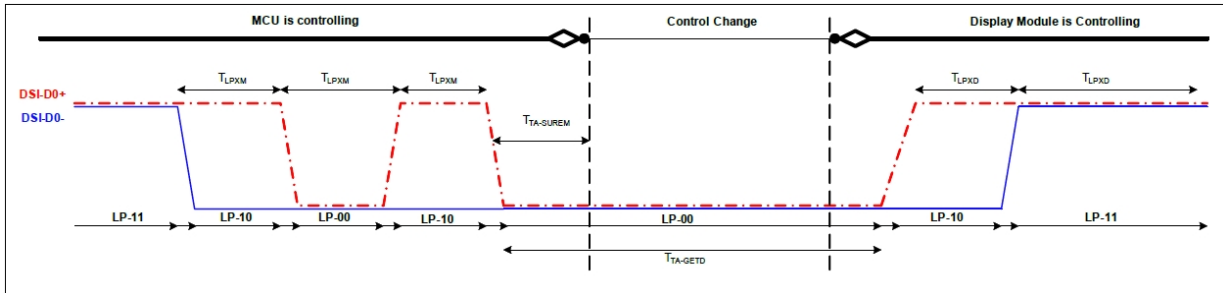

9.2.3 Bursts

High speed data transmission bursts:

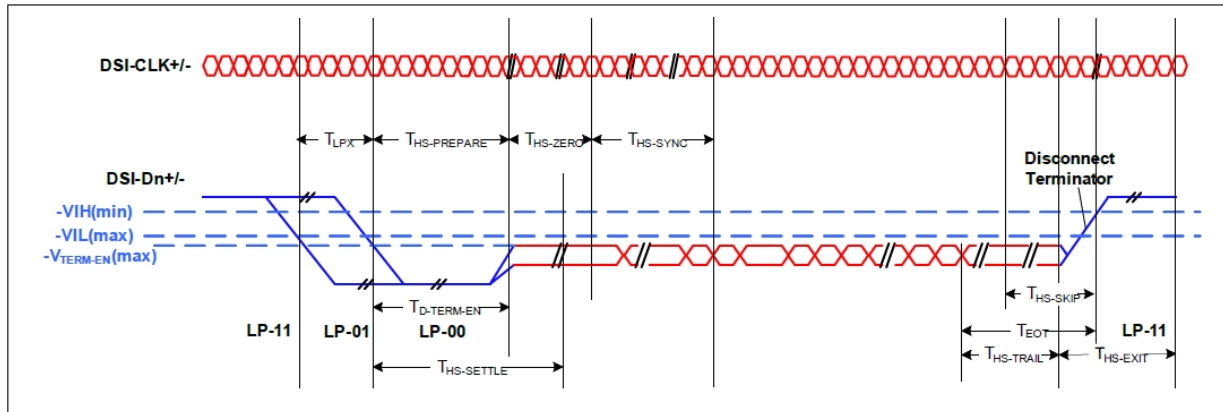

Parameter	Symbol	Parameter	Specification			Unit
			MIN	TYP	MAX	
High Speed Data Transmission Bursts						
DSI-Dn+/-	T _{LPX}	Length of any low-power state period	50	-	-	ns
DSI-Dn+/-	T _{HS-PREPARE}	Time to drive LP-00 to prepare for HS transmission	40ns + 4UI	-	85ns + 6UI	ns
DSI-Dn+/-	T _{HS-PREPARE} + T _{HS-ZERO}	T _{HS-PREPARE} + time to drive HS-0 before the sync sequence	145ns + 10UI	-	-	ns
DSI-Dn+/-	T _{D-TERM-EN}	Time to enable Data Lane receiver line termination measured from when Dn crosses V _{IL(max)}	Time for Dn to reach V _{TERM-EN}	-	35ns + 4UI	ns
DSI-Dn+/-	T _{HS-SKIP}	Time-out at RX to ignore transition period of EoT	40	-	55ns + 4UI	ns
DSI-Dn+/-	T _{HS-TRAIL}	Time to drive flipped differential state after last payload data bit of a HS transmission burst	max (8UI, 60ns+4UI)	-	-	ns
DSI-Dn+/-	T _{HS-EXIT}	Time to drive LP-11 after HS burst	100	-	-	ns
DSI-Dn+/-	T _{EoT}	Time from start of T _{HS-TRAIL} period to start of LP-11 state	-	-	105ns + 12UI	ns

Switching the clock lane between clock transmission and low power mode:

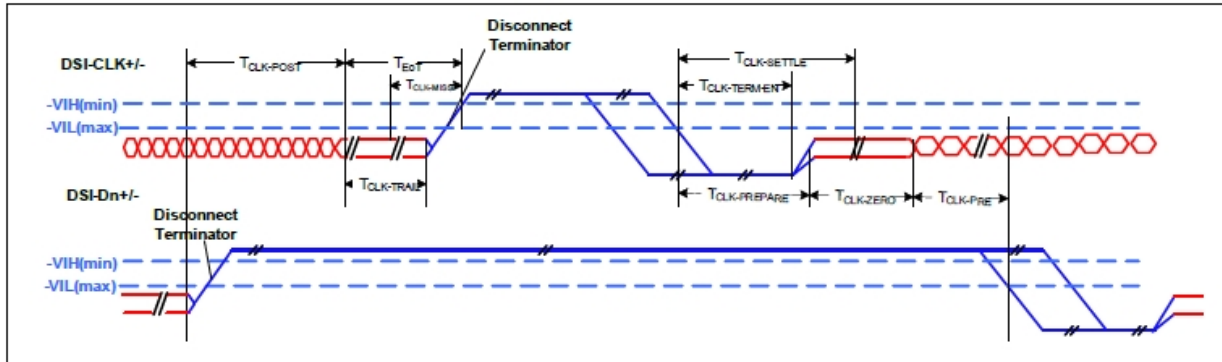

Parameter	Symbol	Parameter	Specification			Unit
			MIN	TYP	MAX	
Switching the clock Lane between clock Transmission and Low Power Mode						
DSI-CLK+/-	$T_{CLK-POST}$	Time that the transmitter shall continue sending HS clock after the last associated Data Lane has transitioned to LP mode	$60ns + 52UI$	-	-	ns
DSI-CLK+/-	$T_{CLK-PRE}$	Time that the HS clock shall be driven prior to any associated Data Lane beginning the transition from LP to HS mode	8	-	-	UI
DSI-CLK+/-	$T_{CLK-PREPARE}$	Time to drive LP-00 to prepare for HS clock transmission	38	-	95	ns
DSI-CLK+/-	$T_{CLK-TERM-EN}$	Time to enable Clock Lane receiver line termination measured from when Dn crosses $V_{IL(max)}$	Time for Dn to reach $V_{TERM-EN}$	-	38	ns
DSI-CLK+/-	$T_{CLK-PREPARE} + T_{CLK-ZERO}$	$T_{CLK-PREPARE}$ + time for lead HS-0 drive period before starting Clock	300	-	-	ns
DSI-CLK+/-	$T_{CLK-TRAIL}$	Time to drive HS differential state after last payload clock bit of a HS transmission burst	60	-	-	ns
DSI-CLK+/-	T_{EoT}	Time from start of $T_{CLK-TRAIL}$ period to start of LP-11 state	-	-	$105ns + 12UI$	ns

10. Reset timing characteristic

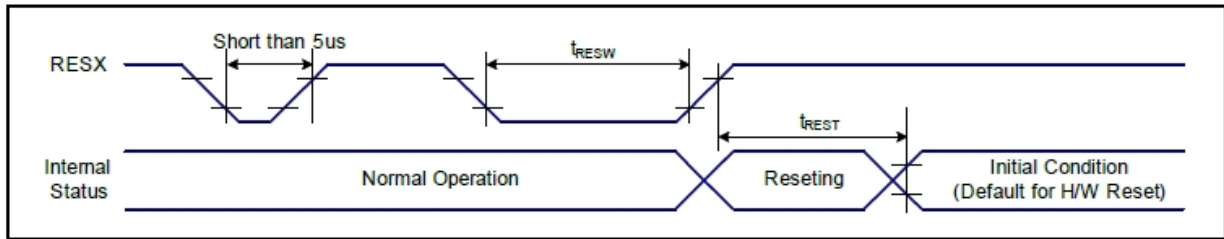

Symbol	Parameter	Related Pins	MIN	TYP	MAX	Note	Unit
t _{RESW}	*1) Reset low pulse width	RESX	10	-	-	-	us
t _{REST}	*2) Reset complete time	-	-	-	5	When reset applied during Sleep in mode	ms
		-	-	-	120	When reset applied during Sleep out mode	ms

Note 1. Spike due to an electrostatic discharge on RESX line does not cause irregular system reset according to the table below.

RESX Pulse	Action
Shorter than 5us	Reset Rejected
Longer than 10us	Reset
Between 5us and 10us	Reset starts (It depends on voltage and temperature condition.)

Note 2. During the resetting period, the display will be blanked (The display is entering blanking sequence, which maximum time is 120 ms, when Reset Starts in Sleep Out –mode. The display remains the blank state in Sleep In –mode) and then return to Default condition for H/W reset.

Note 3. During Reset Complete Time, ID1/ID2/ID3/ID4 and VCOM value in OTP will be latched to internal register during this period. This loading is done every time when there is H/W reset complete time (t_{REST}) within 5ms after a rising edge of RESX.

Note 4. Spike Rejection also applies during a valid reset pulse as shown below:

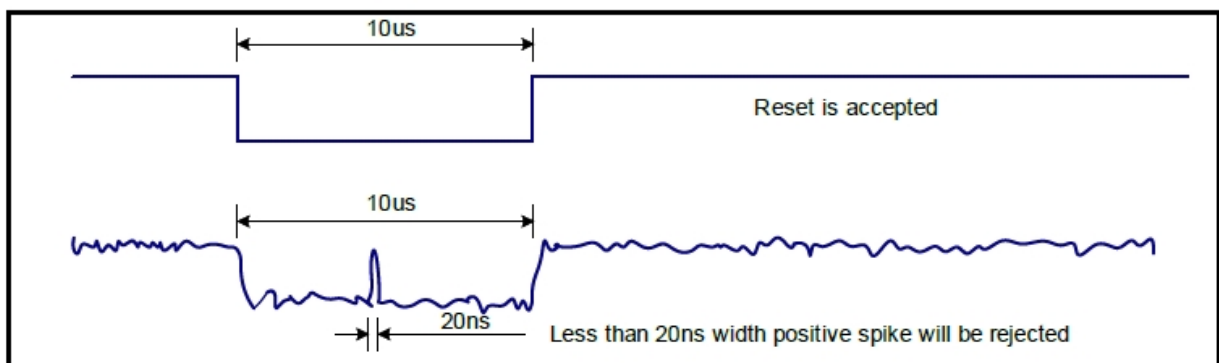

Note 5. It is necessary to wait 5msec after releasing RESX before sending commands. Also Sleep Out command cannot be sent for 120 msec.

11. Quality Assurance

11.1. Purpose

This standard for Quality Assurance assures the quality of LCD module products supplied to customer.

11.2. Standard for Quality Test

11.2.1 Sampling Plan:

GB2828.1-2012

Single sampling, general inspection level II

11.2.2 Sampling Criteria:

Visual inspection: AQL 1.5%

Electrical functional: AQL 0.65%.

11.2.3 Reliability Test:

Detailed requirement refer to Reliability Test Specification.

11.3. Nonconforming Analysis & Disposition

11.3.1 Nonconforming analysis:

11.3.1.1 Customer should provide overall information of non-conforming sample for their complaints.

11.3.1.2 After receipt of detailed information from customer, the analysis of nonconforming parts usually should be finished in one week.

11.3.1.3 If cannot finish the analysis on time, customer will be notified with the progress status.

11.3.2 Disposition of nonconforming:

11.3.2.1 Non-conforming product over PPM level will be replaced.

11.3.2.2 The cause of non-conformance will be analyzed. Corrective action will be discussed and implemented.

11.4. Agreement Items

Shall negotiate with customer if the following situation occurs:

11.4.1 There is any discrepancy in standard of quality assurance.

11.4.2 Additional requirement to be added in product specification.

11.4.3 Any other special problem.

11.5. Standard of the Product Visual Inspection

11.5.1 Appearance inspection:

11.5.1.1 The inspection must be under illumination about 1000 – 1500 lx, and the distance of view must be at 30cm ± 2cm.

11.5.1.2 The viewing angle should be 45° from the vertical line without reflection light or follows customer's viewing angle specifications.

11.5.1.3 Definition of area: A Zone: Active Area, B Zone: Viewing Area,

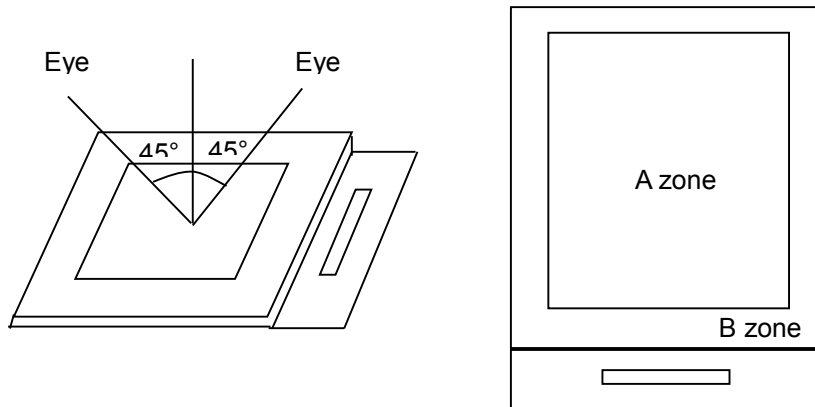

11.5.2 Basic principle:

11.5.2.1 A set of sample to indicate the limit of acceptable quality level must be discussed by both us and customer when there is any dispute happened.

11.5.2.2 New item must be added on time when it is necessary.

11.6. Inspection Specification

No.	Item	Criteria (Unit: mm)																			
01	Black / White spot Foreign material (Round type) Pinholes Stain Particles inside cell. (Minor defect)	<p>$\phi = (a + b) / 2$</p>	<table border="1"> <thead> <tr> <th>Size</th> <th>Area</th> <th>Acc. Qty</th> </tr> </thead> <tbody> <tr> <td>$\phi \leq 0.10$</td> <td></td> <td>Ignore</td> </tr> <tr> <td>$0.10 < \phi \leq 0.15$</td> <td></td> <td>2</td> </tr> <tr> <td>$0.15 < \phi \leq 0.25$</td> <td></td> <td>1</td> </tr> <tr> <td>$0.25 < \phi$</td> <td></td> <td>0</td> </tr> <tr> <td>Total</td> <td></td> <td>2 no include $\phi \leq 0.10$</td> </tr> </tbody> </table>	Size	Area	Acc. Qty	$\phi \leq 0.10$		Ignore	$0.10 < \phi \leq 0.15$		2	$0.15 < \phi \leq 0.25$		1	$0.25 < \phi$		0	Total		2 no include $\phi \leq 0.10$
			Size	Area	Acc. Qty																
$\phi \leq 0.10$		Ignore																			
$0.10 < \phi \leq 0.15$		2																			
$0.15 < \phi \leq 0.25$		1																			
$0.25 < \phi$		0																			
Total		2 no include $\phi \leq 0.10$																			
Distance between 2 defects should more than 3mm apart.																					

02	Electrical Defect (Minor defect)	<table border="1"> <tr> <th></th> <th>Display Area</th> <th>Total</th> <th rowspan="4">Note1</th> </tr> <tr> <td>Bright dot</td> <td>0</td> <td>0</td> </tr> <tr> <td>Dark dot</td> <td>$N \leq 2$</td> <td>$N \leq 2$</td> </tr> <tr> <td>Total dot</td> <td>$N \leq 2$</td> <td>$N \leq 2$</td> </tr> <tr> <td>Mura</td> <td colspan="2">Not visible through 5% ND filters.</td> <td>Note 2</td> </tr> </table>		Display Area	Total	Note1	Bright dot	0	0	Dark dot	$N \leq 2$	$N \leq 2$	Total dot	$N \leq 2$	$N \leq 2$	Mura	Not visible through 5% ND filters.		Note 2
			Display Area	Total	Note1														
		Bright dot	0	0															
		Dark dot	$N \leq 2$	$N \leq 2$															
		Total dot	$N \leq 2$	$N \leq 2$															
Mura	Not visible through 5% ND filters.		Note 2																
Remark:																			
1. Bright dot caused by scratch and foreign object accords to item 1.																			
03	Black and White line Scratch Foreign material (Line type) (Minor defect)																		
		<table border="1"> <thead> <tr> <th>Length</th> <th>Width</th> <th>Acc. Qty</th> </tr> </thead> <tbody> <tr> <td>/</td> <td>$W \leq 0.03$</td> <td>Ignore</td> </tr> <tr> <td>$L \leq 2.5$</td> <td>$0.03 < W \leq 0.05$</td> <td>3</td> </tr> <tr> <td>$L \leq 2.5$</td> <td>$0.05 < W \leq 0.10$</td> <td>2</td> </tr> <tr> <td>/</td> <td>$0.1 < W$</td> <td>0</td> </tr> <tr> <td colspan="2">Total</td> <td>3</td> </tr> </tbody> </table>	Length	Width	Acc. Qty	/	$W \leq 0.03$	Ignore	$L \leq 2.5$	$0.03 < W \leq 0.05$	3	$L \leq 2.5$	$0.05 < W \leq 0.10$	2	/	$0.1 < W$	0	Total	
Length	Width	Acc. Qty																	
/	$W \leq 0.03$	Ignore																	
$L \leq 2.5$	$0.03 < W \leq 0.05$	3																	
$L \leq 2.5$	$0.05 < W \leq 0.10$	2																	
/	$0.1 < W$	0																	
Total		3																	
Distance between 2 defects should more than 3mm apart. Scratches not viewable through the back of the display are acceptable.																			
04	Glass Crack (Minor defect)																		
		Crack is potential to enlarge, any type is not allowed.																	

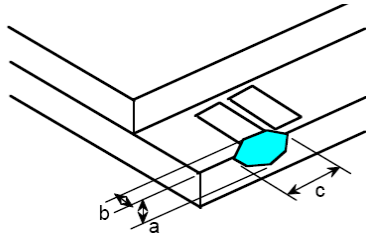
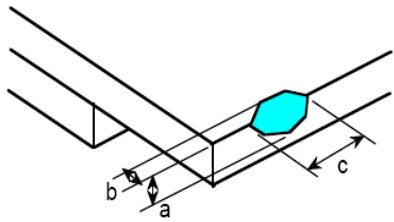
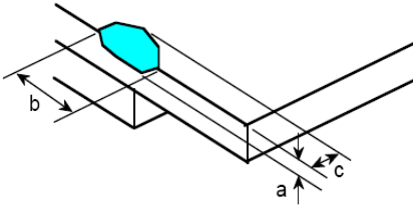
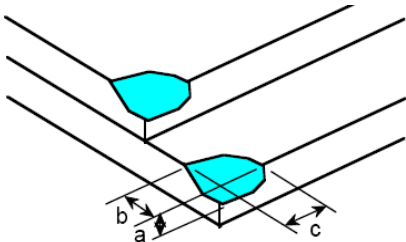
<p>05</p>	<p>Glass Chipping Pad Area: (Minor defect)</p> 	<table border="1"> <thead> <tr> <th>Length and Width</th> <th>Acc. Qty</th> </tr> </thead> <tbody> <tr> <td>$c > 3.0, b < 1.0$</td> <td>1</td> </tr> <tr> <td>$c < 3.0, b < 1.0$</td> <td>3</td> </tr> <tr> <td colspan="2">$a < \text{Glass Thickness}$</td> </tr> </tbody> </table>	Length and Width	Acc. Qty	$c > 3.0, b < 1.0$	1	$c < 3.0, b < 1.0$	3	$a < \text{Glass Thickness}$			
Length and Width	Acc. Qty											
$c > 3.0, b < 1.0$	1											
$c < 3.0, b < 1.0$	3											
$a < \text{Glass Thickness}$												
<p>06</p>	<p>Glass Chipping Rear of Pad Area: (Minor defect)</p> 	<table border="1"> <thead> <tr> <th>Length and Width</th> <th>Acc. Qty</th> </tr> </thead> <tbody> <tr> <td>$c > 3.0, b < 1.0$</td> <td>1</td> </tr> <tr> <td>$c < 3.0, b < 1.0$</td> <td>2</td> </tr> <tr> <td>$c < 3.0, b < 0.5$</td> <td>4</td> </tr> <tr> <td colspan="2">$a < \text{Glass Thickness}$</td> </tr> </tbody> </table>	Length and Width	Acc. Qty	$c > 3.0, b < 1.0$	1	$c < 3.0, b < 1.0$	2	$c < 3.0, b < 0.5$	4	$a < \text{Glass Thickness}$	
Length and Width	Acc. Qty											
$c > 3.0, b < 1.0$	1											
$c < 3.0, b < 1.0$	2											
$c < 3.0, b < 0.5$	4											
$a < \text{Glass Thickness}$												
<p>07</p>	<p>Glass Chipping Except Pad Area: (Minor defect)</p> 	<table border="1"> <thead> <tr> <th>Length and Width</th> <th>Acc. Qty</th> </tr> </thead> <tbody> <tr> <td>$c > 3.0, b < 1.0$</td> <td>1</td> </tr> <tr> <td>$c < 3.0, b < 1.0$</td> <td>2</td> </tr> <tr> <td>$c < 3.0, b < 0.5$</td> <td>4</td> </tr> <tr> <td colspan="2">$a < \text{Glass Thickness}$</td> </tr> </tbody> </table>	Length and Width	Acc. Qty	$c > 3.0, b < 1.0$	1	$c < 3.0, b < 1.0$	2	$c < 3.0, b < 0.5$	4	$a < \text{Glass Thickness}$	
Length and Width	Acc. Qty											
$c > 3.0, b < 1.0$	1											
$c < 3.0, b < 1.0$	2											
$c < 3.0, b < 0.5$	4											
$a < \text{Glass Thickness}$												
<p>08</p>	<p>Glass Corner Chipping: (Minor defect)</p> 	<table border="1"> <thead> <tr> <th>Length and Width</th> <th>Acc. Qty</th> </tr> </thead> <tbody> <tr> <td>$c < 3.0, b < 3.0$</td> <td>Ignore</td> </tr> <tr> <td colspan="2">$a < \text{Glass Thickness}$</td> </tr> </tbody> </table>	Length and Width	Acc. Qty	$c < 3.0, b < 3.0$	Ignore	$a < \text{Glass Thickness}$					
Length and Width	Acc. Qty											
$c < 3.0, b < 3.0$	Ignore											
$a < \text{Glass Thickness}$												

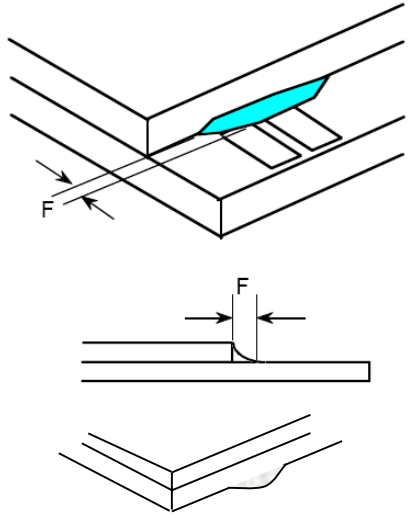
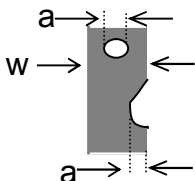
<p>09</p>	<p>Glass Burr: (Minor defect)</p> 	<table border="1" data-bbox="853 264 1324 353"> <thead> <tr> <th>Length</th> <th>Acc. Qty</th> </tr> </thead> <tbody> <tr> <td>F < 1.0</td> <td>Ignore</td> </tr> </tbody> </table> <p>Glass burr don't affect assemble and module dimension.</p>	Length	Acc. Qty	F < 1.0	Ignore						
Length	Acc. Qty											
F < 1.0	Ignore											
<p>10</p>	<p>FPC Defect: (Minor defect)</p> 	<p>10.1 Dent, pinhole width $a < w/3$. (w: circuitry width.)</p> <p>10.2 Open circuit is unacceptable.</p> <p>10.3 No oxidation, contamination and distortion.</p>										
<p>11</p>	<p>Bubble on Polarizer (Minor defect)</p>	<table border="1" data-bbox="726 1339 1197 1554"> <thead> <tr> <th>Diameter</th> <th>Acc. Qty</th> </tr> </thead> <tbody> <tr> <td>$\varphi \leq 0.20$</td> <td>Ignore</td> </tr> <tr> <td>$0.20 < \varphi \leq 0.30$</td> <td>4</td> </tr> <tr> <td>$0.30 < \varphi \leq 0.50$</td> <td>1</td> </tr> <tr> <td>$0.50 < \varphi$</td> <td>None</td> </tr> </tbody> </table>	Diameter	Acc. Qty	$\varphi \leq 0.20$	Ignore	$0.20 < \varphi \leq 0.30$	4	$0.30 < \varphi \leq 0.50$	1	$0.50 < \varphi$	None
Diameter	Acc. Qty											
$\varphi \leq 0.20$	Ignore											
$0.20 < \varphi \leq 0.30$	4											
$0.30 < \varphi \leq 0.50$	1											
$0.50 < \varphi$	None											
<p>12</p>	<p>Dent on Polarizer (Minor defect)</p>	<table border="1" data-bbox="726 1615 1197 1830"> <thead> <tr> <th>Diameter</th> <th>Acc. Qty</th> </tr> </thead> <tbody> <tr> <td>$\varphi \leq 0.20$</td> <td>Ignore</td> </tr> <tr> <td>$0.20 < \varphi \leq 0.30$</td> <td>4</td> </tr> <tr> <td>$0.30 < \varphi \leq 0.50$</td> <td>1</td> </tr> <tr> <td>$0.50 < \varphi$</td> <td>None</td> </tr> </tbody> </table>	Diameter	Acc. Qty	$\varphi \leq 0.20$	Ignore	$0.20 < \varphi \leq 0.30$	4	$0.30 < \varphi \leq 0.50$	1	$0.50 < \varphi$	None
Diameter	Acc. Qty											
$\varphi \leq 0.20$	Ignore											
$0.20 < \varphi \leq 0.30$	4											
$0.30 < \varphi \leq 0.50$	1											
$0.50 < \varphi$	None											
<p>13</p>	<p>Bezel</p>	<p>13.1 No rust, distortion on the Bezel.</p> <p>13.2 No visible fingerprints, stains or other contamination.</p>										

14	Touch Panel	<p>D: Diameter W: width L: length</p> <p>14.1 Spot: $D < 0.25$ is acceptable $0.25 \leq D \leq 0.4$</p> <p>2dots are acceptable and the distance between defects should more than 10 mm.</p> <p>$D > 0.4$ is unacceptable</p> <p>14.2 Dent: $D > 0.40$ is unacceptable</p> <p>14.3 Scratch: $W \leq 0.03$, $L \leq 10$ is acceptable, $0.03 < W \leq 0.10$, $L \leq 10$ is acceptable</p> <p>Distance between 2 defects should more than 10 mm. $W > 0.10$ is unacceptable.</p>
15	PCB	<p>15.1 No distortion or contamination on PCB terminals.</p> <p>15.2 All components on PCB must same as documented on the BOM/component layout.</p> <p>15.3 Follow IPC-A-600F.</p>
16	Soldering	Follow IPC-A-610C standard
17	Electrical Defect (Major defect)	<p>The below defects must be rejected.</p> <p>17.1 Missing vertical / horizontal segment,</p> <p>17.2 Abnormal Display.</p> <p>17.3 No function or no display.</p> <p>17.4 Current exceeds product specifications.</p> <p>17.5 LCD viewing angle defect.</p> <p>17.6 No Backlight.</p> <p>17.7 Dark Backlight.</p> <p>17.8 Touch Panel no function.</p>

Remark: LCD Panel Broken shall be rejected. Defect out of LCD viewing area is acceptable.

11.7. Classification of Defects

11.7.1 Visual defects (Except no / wrong label) are treated as minor defect and electrical defect is major.

11.7.2 Two minor defects are equal to one major in lot sampling inspection.

11.8. Identification/marketing criteria

Any unit with illegible / wrong /double or no marking/ label shall be rejected.

11.9. Packaging

11.9.1 There should be no damage of the outside carton box, each packaging box should have one identical label.

11.9.2 Modules inside package box should have compliant mark.

11.9.3 All direct package materials shall offer ESD protection

Note1: Bright dot is defined as the defective area of the dot is larger than 50% of one sub-pixel area.

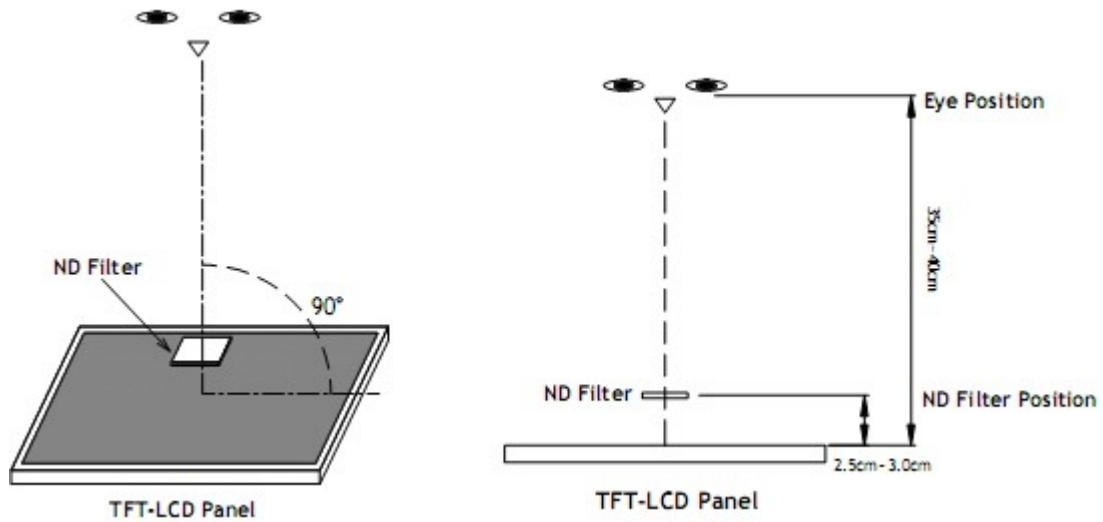

Bright dot: The bright dot size defect at black display pattern. It can be recognized by 2% transparency of filter when the distance between eyes and panel is $350\text{mm} \pm 50\text{mm}$.

Dark dot: Cyan, Magenta or Yellow dot size defect at white display pattern. It can be recognized by 5% transparency of filter when the distance between eyes and panel is $350\text{mm} \pm 50\text{mm}$.

Note2: Mura on display which appears darker / brighter against background brightness on parts of display area.

12. Reliability Specification

No	Item	Condition	Quantity	Criteria
1	High Temperature Operating	+70°C, 96Hrs	2	GB/T2423.2-2008
2	Low Temperature Operating	-20°C, 96Hrs	2	GB/T2423.1-2008
3	High Humidity	+50°C, 90%RH, 96Hrs	2	GB/T2423.3-2006
4	High Temperature Storage	+80°C, 96Hrs	2	GB/T2423.2-2008
5	Low Temperature Storage	-30°C, 96Hrs	2	GB/T2423.1-2008
6	Thermal Cycling Test	-20°C, 60min ~ +70°C, 60min, 20 cycles.	2	GB/T2423.22-2012
7	Packing vibration	Frequency range:10Hz~50Hz Acceleration of gravity:5G X, Y, Z 30 min for each direction.	2	GB/T5170.14-2009
8	Electrical Static Discharge	Air: ±4KV 150pF/330Ω 5 times Contact: ±2KV 150pF/330Ω 5 times	2	GB/T17626.2-2006
9	Drop Test (Packaged)	Height:80 cm,1 corner, 3 edges, 6 surfaces.	2	GB/T2423.8-1995

Note1. No defection cosmetic and operational function allowable.

Note2. Total current Consumption should be below double of initial value

13. Precautions and Warranty

13.1 Safety

- 13.1.1. The liquid crystal in the LCD is poisonous. Do not put it in your mouth. If the liquid crystal touches your skin or clothes, wash it off immediately using soap and water.
- 13.1.2. Since the liquid crystal cells are made of glass, do not apply strong impact on them. Handle with care.

13.2. Handling

- 13.2.1. Reverse and use within ratings in order to keep performance and prevent damage.
- 13.2.2. Do not wipe the polarizer with dry cloth, as it might cause scratch. If the surface of the LCD needs to be cleaned, wipe it swiftly with cotton or other soft cloth soaked with petroleum IPA, do not use other chemicals.

13.3. Storage

- 13.3.1 Do not store the LCD module beyond the specified temperature ranges.

13.4. Metal Pin (Apply to Products with Metal Pins)

13.4.1. Pins of LCD and Backlight

- 13.4.1.1. Solder tip can touch and press on the tip of Pin LEAD during the soldering

13.4.1.2. Recommended Soldering Conditions

Solder Type: Sn96.3~94-Ag3.3~4.3-Cu0.4~1.1

Maximum Solder Temperature: 370℃

Maximum Solder Time: 3s at the maximum temperature

Recommended Soldering Temp: 350±20℃

Typical Soldering Time: ≤3s

13.4.1.3. Solder Wetting

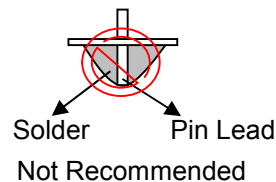
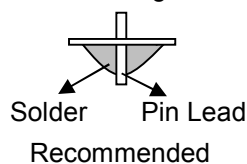

13.4.2. Pins of EL

- 13.4.2.1. Solder tip can touch and press on the tip of EL leads during soldering.

- 13.4.2.2. No Solder Paste on the soldering pad on the motherboard is recommended.

13.4.2.3. Recommended Soldering Conditions

Solder type: Nippon Alimit Leadfree SR-34, size 0.5mm

Recommended Solder Temperature: 270~290℃

Typical Soldering Time: ≤2s

Minimum solder distance from EL lamp (body):2.0mm

- 13.4.2.4. No horizontal press on the EL leads during soldering.

- 13.4.2.5. 180° bend EL leads three times is not allowed.

13.4.2.6. Solder Wetting

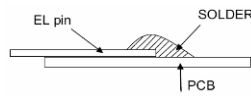

Recommended

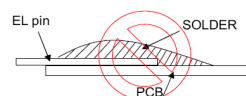

Not Recommended

13.4.2.7. The type of the solder iron:

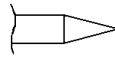

Recommended

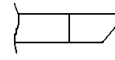

Not Recommended

13.4.2.8. Solder Pad

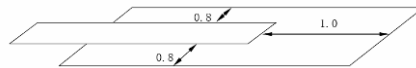

13.5. Operation

- 13.5.1. Do not drive LCD with DC voltage
- 13.5.2. Response time will increase below lower temperature
- 13.5.3. Display may change color with different temperature
- 13.5.4. Mechanical disturbance during operation, such as pressing on the display area, may cause the segments to appear “fractured”.

13.6. Static Electricity

- 13.6.1. CMOS LSIs are equipped in this unit, so care must be taken to avoid the electro-static charge, by ground human body, etc.
- 13.6.2. The normal static prevention measures should be observed for work clothes and benches.
- 13.6.3. The module should be kept into anti-static bags or other containers resistant to static for storage.

13.7. Limited Warranty

- 13.7.1. Our warranty liability is limited to repair and/or replacement. We will not be responsible for any consequential loss.
- 13.7.2. If possible, we suggest customer to use up all modules in six months. If the module storage time over twelve months, we suggest that recheck it before the module be used.
- 13.7.3. After the product shipped, any product quality issues must be feedback within three months, otherwise, we will not be responsible for the subsequent or consequential events.

14. Outline Drawing

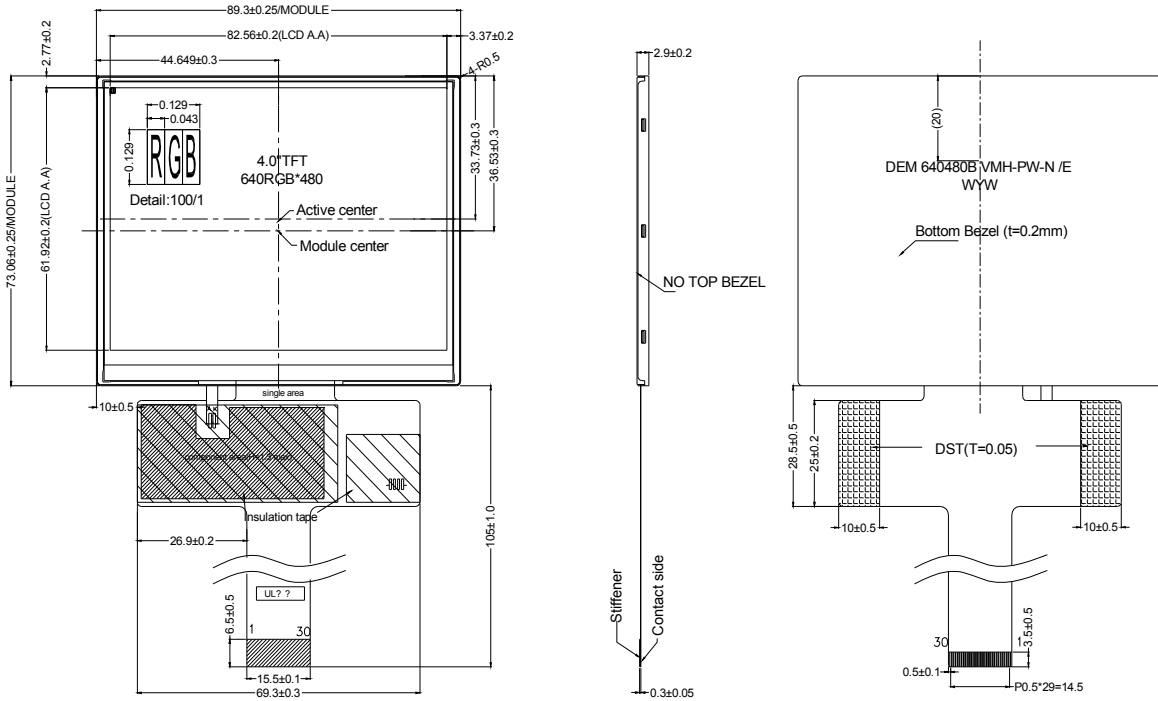

NOTES:

1. Display Type: 4.0" TFT (IPS)
 2. Viewing Direction: FULL VIEW
 3. Polarizer Mode: Transmissive / Normal Black / Glare
 4. Operation Temperature: -20° C to +70° C
 5. Storage Temperature: -30° C to +80° C
 6. Driver IC: OTM1287A (Focaltech)
 7. Logic Power Supply Voltage: 3.3V (typ.)
 8. Backlight: White (10xLEDs) / 16V/40mA (typ.)
 9. Luminance: 480cd/m2 (typ.)
 10. ROHS must be complied
- * Unspecification tolerance are ±0.2mm

B/L CIRCUIT DIAGRAM

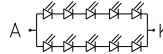

PIN	SYMBOL	Pin assignment
1	VLED-	
2	VLED+	
3	VDD	
4	GND	
5	D0P	
6	D0N	
7	GND	
8	D1P	
9	D1N	
10	GND	
11	CLKP	
12	CLKN	
13	GND	
14	D2P	
15	D2N	
16	GND	
17	D3P	
18	D3N	
19	GND	
20	NC	
21	NC	
22	NC	
23	GND	
24	NC	
25	XR(NC)	
26	YD(NC)	
27	XL(NC)	
28	YU(NC)	
29	NC	
30	NC	