

Display Elektronik GmbH

DATA SHEET

TFT MODULE

**DEM 480272J VMH-PW-N
(A-TOUCH)**

4,3" TFT + Touch

Product Specification

Ver.: 1

28.05.2015

Revision History

Revision	Date	Originator	Remarks
0	17.04.2015	DS	-
1	28.05.2015	Modify Chromacity Transmissive	P7

Table of Contents

No.	Item	Page
1.	General Description	4
2.	Module Parameter	4
3.	Absolute Maximum Ratings	5
4.	DC Characteristics	5
5.	Backlight Characteristic	6
5.1.	Backlight Characteristics.....	6
5.2.	Backlighting circuit	6
6.	Touch Screen Panel Specifications.....	7
7.	Optical Characteristics	8
7.1.	Optical Characteristics	8
7.2.	Definition of Response Time	8
7.3.	Definition of Contrast Ratio	9
7.4.	Definition of Viewing Angles.....	9
7.5.	Definition of Color Appearance	10
7.6.	Definition of Surface Luminance, Uniformity and Transmittance.....	10
8.	Block Diagram and Power Supply	11
9.	Interface Pins Definition	12
10.	AC Characteristics	13
11.	AC Timing Diagram.....	13
12.	INPUT DATA FORMAT	14
13.	Quality Assurance	15
13.1	Purpose.....	15
13.2	Standard for Quality Test.....	15
13.3	Nonconforming Analysis & Disposition	15
13.4	Agreement Items.....	15
13.5	Standard of the Product Visual Inspection.....	16
13.6	Inspection Specification	17
13.7	Classification of Defects.....	22
13.8	Identification/marketing criteria	22
13.9	Packaging	22
14.	Reliability Specification	23
15.	Precautions and Warranty	24
15.1	Safety	24
15.2	Handling	24
15.3	Storage	24
15.4	Metal Pin (Apply to Products with Metal Pins)	24
15.5	Operation	25
15.6	Static Electricity	25
15.7	Limited Warranty.....	25
16.	Outline Drawing	26

1. General Description

The specification is a transmissive type color active matrix liquid crystal display (LCD) which uses amorphous thin film transistor (TFT) as switching devices. This product is composed of a TFT-LCD panel, driver ICs, a touch panel and a backlight unit.

2. Module Parameter

Features	Details	Unit
Display Size (Diagonal)	4.3"	-
LCD Type	MVA TFT	-
Display Mode	Transmissive / Normally White	-
Resolution	480 x RGB x 272	Pixels
View Direction	FULL VIEW	Best Image
Module Outline	105.50 x 67.20 x 4.10 (Note1)	mm
Active Area	95.04 x 53.86	mm
Pixel Pitch	0.198 x 0.198	mm
Pixel Arrangement	Stripe	-
Polarizer Surface Treatment	Anti-Glare	-
Display Colors	16,7 Million	-
Interface	24-Bit-RGB-Interface	-
Driver IC	OTA5180A (Orisetech)	-
With or Without Touch Panel	With Touch	-
Operating Temperature	-20°C to +70°C	°C
Storage Temperature	-30°C to +80°C	°C
Weight	60	g

Note 1: Exclusive hooks, posts, FFC/FPC tail etc.

3. Absolute Maximum RatingsV_{SS}=0V, Ta=25°C

Item	Symbol	Min.	Max.	Unit
Supply Voltage	V _{DD}	-0.3	4.5	V
Storage Temperature	T _{STG}	-30	+80	°C
Operating Temperature	T _{OP}	-20	+70	°C

Note 1: If Ta below 50°C, the maximal humidity is 90%RH, if Ta over 50°C, absolute humidity should be less than 60%RH.

Note 2: The response time will be extremely slow when the operating temperature is around -10°C, and the back ground will become darker at high temperature operating.

4. DC Characteristics

Item	Symbol	Min.	Typ.	Max.	Unit
Digital Interface Supply Voltage	V _{DD}	3.0	3.3	3.6	V
Logic Low Input Voltage	V _{IL}	GND	-	0.3*V _{DD}	V
Logic High Input Voltage	V _{IH}	0.7*V _{DD}	-	V _{DD}	V
Logic Low Output Voltage	V _{OL}	GND	-	GND+0.4	V
Logic High Output Voltage	V _{OH}	V _{DD} -0.4	-	V _{DD}	V
Current Consumption All Black	I _{CC+ I_{IN}}	-	25	60	mA
	Analog				

5. Backlight Characteristic

5.1. Backlight Characteristics

Item	Symbol	Condition	Min.	Typ.	Max.	Unit
Forward Voltage	V _F	T _a =25°C, I _F =20mA/LED	14.5	16.0	16.5	V
Forward Current	I _F	T _a =25°C, V _F =3.2V/LED	-	60	-	mA
Power Dissipation	P _D		-	960	-	mW
Uniformity	Avg		-	80	-	%
LED Lifetime (25°C)	-		-	30,000	-	Hrs
Drive Method	Constant current					
LED Configuration	15 White LEDs (5LEDs in one string and 3 groups in parallel)					

Note: LED life time defined as follows: The final brightness is at 50% of original brightness.

The environmental conducted under ambient air flow, at T_a=25±2°C, 60%RH±5%, I_F=20mA

5.2. Backlighting Circuit

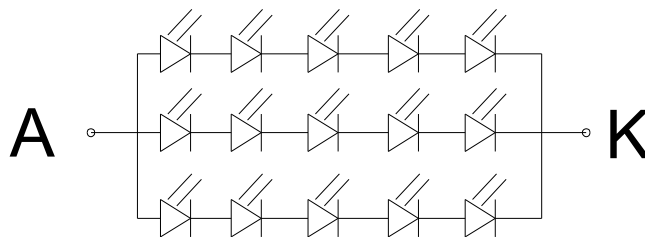

6. Touch Screen Panel Specifications

6.1 Electrical Characteristics

Item	Min.	Typ.	Max.	Unit	Note
Linearity	-1.5	-	1.5	%	Analog X and Y directions
Terminal Resistance	400	-	1300	Ω	X (Film side)
	100	-	540	Ω	Y (Glass side)
Insulation Resistance	20	-	-	MΩ	DC ≤10V
Voltage	-	-	10	V	DC
Chattering	-	-	10	ms	

Caution (1): Do not operate it with a thing except a polyacetal pen (tip R0.8mm or less) or a finger, especially those with hard or sharp tips such as a ball point pen or a mechanical pencil.

6.2 Mechanical & Reliability Characteristics

Item	Min.	Typ.	Max.	Unit	Note
Activation Force	20	-	100	g	(1)
Durability-Surface Scratching	Write 20,000	-	-	characters	(2)
Durability-Surface Pitting	1,000,000	-	-	touches	(3)
Surface Hardness	3	-	-	H	

Note (1) Stylus pen Input: R0.8mm polyacetal pen or Finger

Note (2) Measurement for Surface area

- Force: 150-250gf
- Speed: 60mm/sec
- Stylus: R0.8 polyacetal pen or Finger

Note (3) Pit 1,000,000 times on the Film with a R3.75 silicon rubber.

- Force: Force: 2.45N
- Speed: 3times/sec

7. Optical Characteristics

7.1. Optical Characteristics

Ta=25°C, V_{DD} =3.3V

	Item	Symbol	Condition	Specification			Unit	
				Min.	Typ.	Max.		
Backlight On (Transmissive Mode)	Luminance on TFT(I _f =20mA/LED)	Lv	Normally viewing angle θ _x = φ _y =0°	265	330	-	cd/m ²	
	Contrast Ratio(See 7.3)	CR		250	350	-		
	Response Time (See 7.2)	T _R +T _F		-	30	45	ms	
	Chromaticity Transmissive (See 7.5)	Red	X _R	Center CR≥10	0.546	0.596	0.646	
			Y _R		0.296	0.346	0.396	
		Green	X _G		0.278	0.328	0.378	
			Y _G		0.578	0.628	0.678	
		Blue	X _B		0.101	0.151	0.201	
			Y _B		0.083	0.133	0.183	
	White	X _w	0.252	0.302	0.352			
Y _w		0.309	0.359	0.409				
Viewing Angle (See 7.4)	Horizontal	θ _{x+}	Center CR≥10	60	75	-	Deg.	
		θ _{x-}		60	75	-		
	Vertical	φ _{y+}		60	75	-		
		φ _{y-}		60	75	-		
NTSC Ratio(Gamut)				-	50	-	%	

7.2. Definition of Response Time

7.2.1. Normally Black Type (Negative)

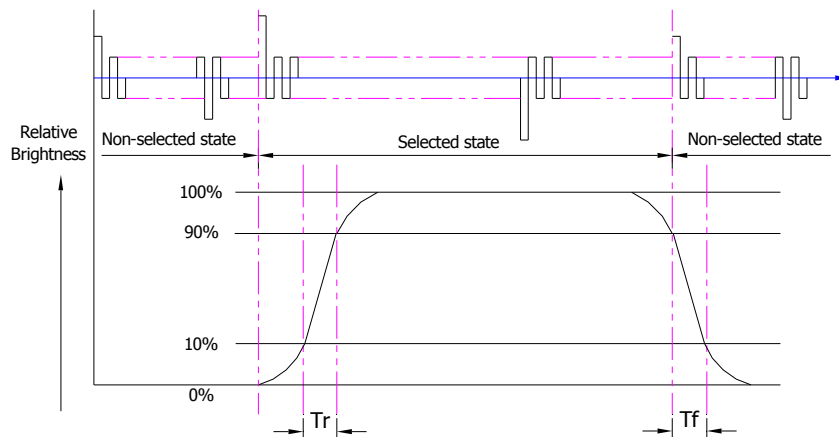

Tr is the time it takes to change form non-selected stage with relative luminance 10% to selected state with relative luminance 90%;

Tf is the time it takes to change from selected state with relative luminance 90% to non-selected state with relative luminance 10%.

Note : Measuring machine: LCD-5100

7.2.2. Normally White Type (Positive)

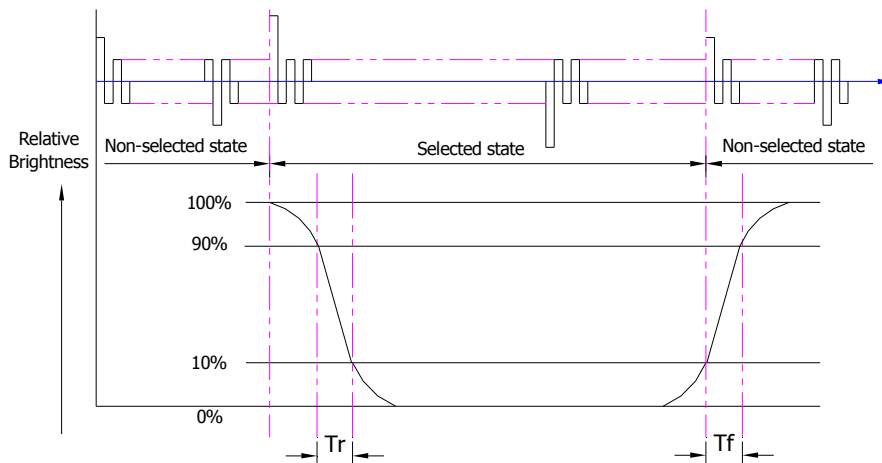

Tr is the time it takes to change from non-selected state with relative luminance 90% to selected state with relative luminance 10%;

Tf is the time it takes to change from selected state with relative luminance 10% to non-selected state with relative luminance 90%;

Note : Measuring machine: LCD-5100 or EQUI

7.3. Definition of Contrast Ratio

Contrast is measured perpendicular to display surface in reflective and transmissive mode.

The measurement condition is:

Measuring Equipment	Eldim or Equivalent
Measuring Point Diameter	3mm//1mm
Measuring Point Location	Active Area centre point
Test pattern	A: All Pixels white
	B: All Pixel black
Contrast setting	Maximum

Definitions: CR (Contrast) = Luminance of White Pixel / Luminance of Black Pixel

7.4. Definition of Viewing Angles

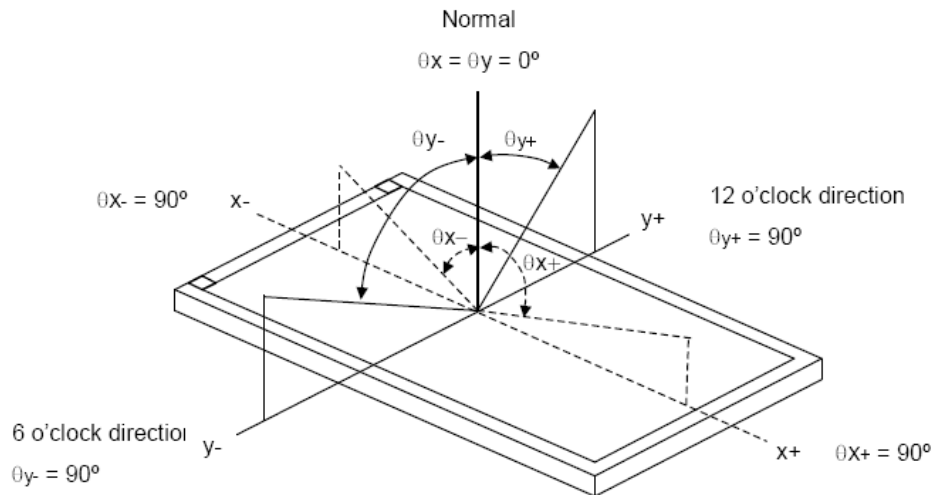

Measuring machine: LCD-5100 or EQUI

7.5. Definition of Color Appearance

R,G,B and W are defined by (x, y) on the IE chromaticity diagram

NTSC=area of RGB triangle/area of NTSC triangleX100%

Measuring picture: Red, Green, Blue and White (Measuring machine: BM-7)

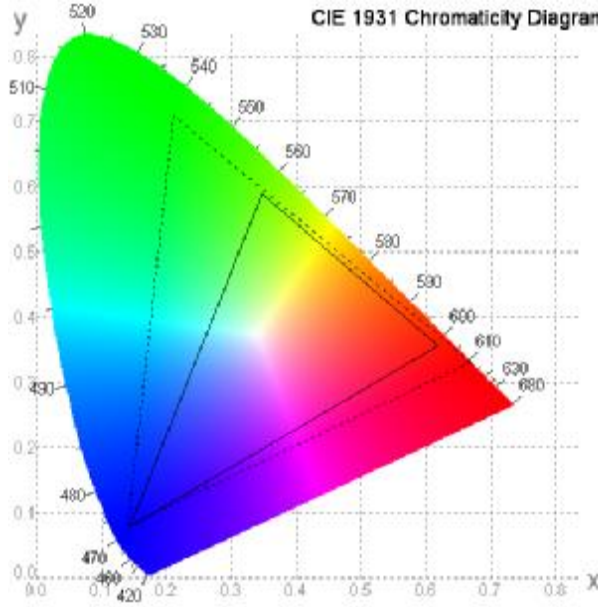

7.6. Definition of Surface Luminance, Uniformity and Transmittance

Using the transmissive mode measurement approach, measure the white screen luminance of the display panel and backlight.

7.6.1. Surface Luminance: $L_v = \text{average} (L_{P1}:L_{P9})$

7.6.2. Uniformity = $\text{Minimal} (L_{P1}:L_{P9}) / \text{Maximal} (L_{P1}:L_{P9}) * 100\%$

7.6.3. Transmittance = $L_v \text{ on LCD} / L_v \text{ on Backlight} * 100\%$

Note: Measuring machine: BM-7

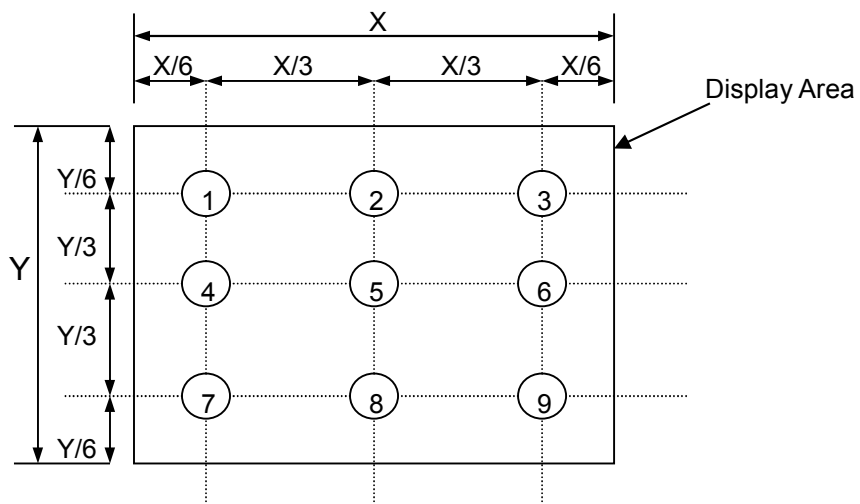

8. Block Diagram and Power Supply

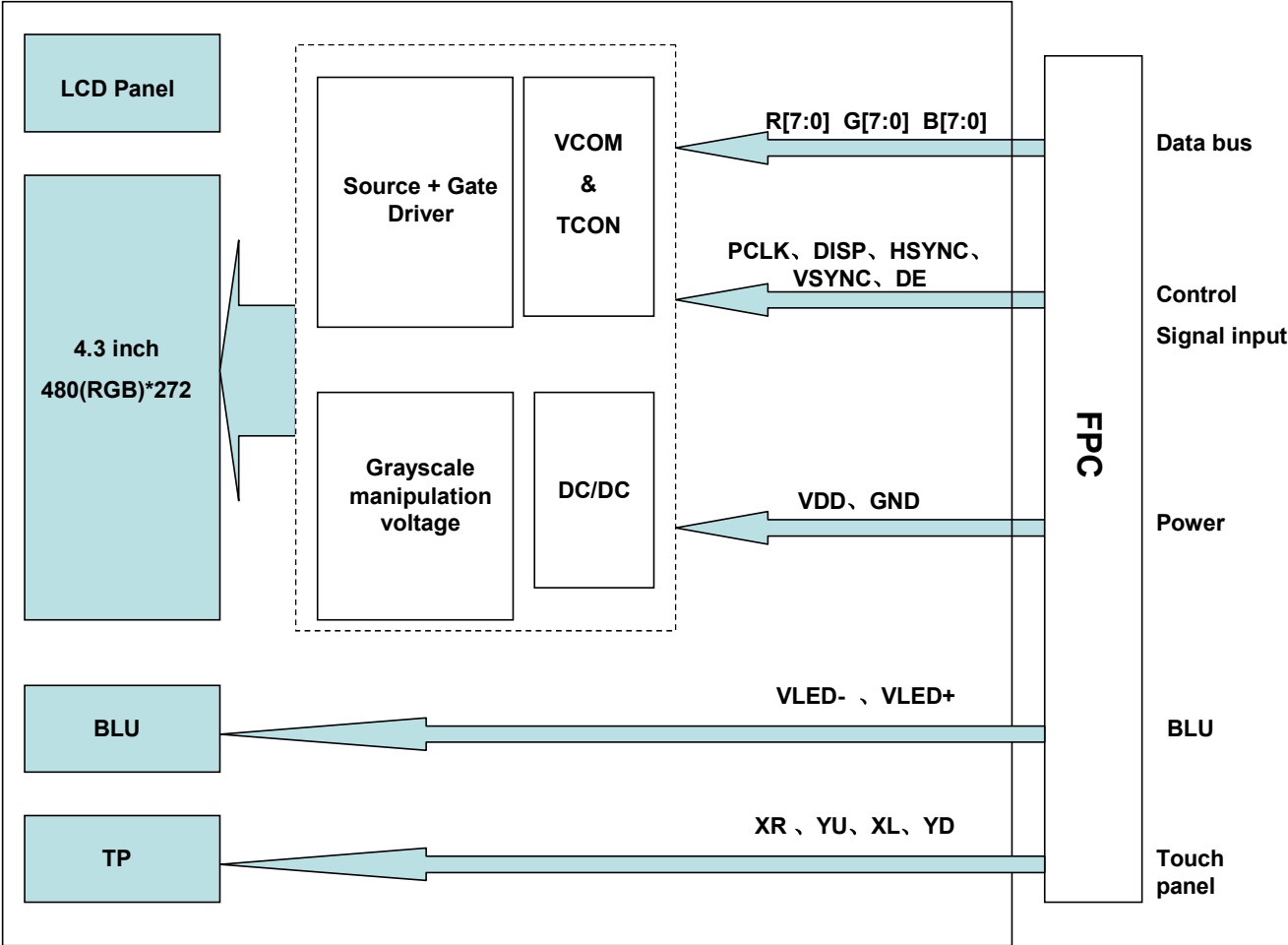

9. Interface Pins Definition

No.	Symbol	Function	Remark
1	VLED-	Backlight Cathode	
2	VLED+	Backlight Anode	
3	GND	Ground	
4	VDD	Power source	
5	R0	Red data signal	
6	R1	Red data signal	
7	R2	Red data signal	
8	R3	Red data signal	
9	R4	Red data signal	
10	R5	Red data signal	
11	R6	Red data signal	
12	R7	Red data signal	
13	G0	Green data signal	
14	G1	Green data signal	
15	G2	Green data signal	
16	G3	Green data signal	
17	G4	Green data signal	
18	G5	Green data signal	
19	G6	Green data signal	
20	G7	Green data signal	
21	B0	Blue data signal	
22	B1	Blue data signal	
23	B2	Blue data signal	
24	B3	Blue data signal	
25	B4	Blue data signal	
26	B5	Blue data signal	
27	B6	Blue data signal	
28	B7	Blue data signal	
29	GND	Ground	
30	PCLK	Clock signal to sample each data	
31	DISP	Display on/off signal. DISP="H" Display on; DISP="L" Display off	
32	HSYNC	Horizontal synchronizing signal	
33	VSYNC	Vertical synchronizing signal	
34	DE	Input data enable control.	
35	NC	No connection	
36	GND	Ground	
37	XR	Touch panel terminal	
38	YD	Touch panel terminal	
39	XL	Touch panel terminal	
40	YU	Touch panel terminal	

10. AC Characteristics

VDDIO=1.8V, VDD = 3.3V, AVDD = 6V, AGND = 0V, T_A = -20°C to 80°C

Item	Symbol	Min.	Typ.	Max.	Unit	Conditions
CLK pulse duty	T _{cw}	40	50	60	%	
Hsync width	T _{hw}	1.0	-	-	DCLK	
Hsync period	T _h	55	60	65	us	
Vsync setup time	T _{vst}	12	-	-	ns	
Vsync hold time	T _{vhd}	12	-	-	ns	
Hsync setup time	T _{hst}	12	-	-	ns	
Hsync hold time	T _{hhd}	12	-	-	ns	
Data set-up time	T _{dsu}	12	-	-	ns	
Data hold time	T _{dhd}	12	-	-	ns	
DE set-up time	T _{desu}	12	-	-	ns	
DE hold time	T _{d ehd}	12	-	-	ns	
SD output stable time	T _{st}	-	10	12	us	
GD output rise and fall time	T _{gst}	-	500	1000	ns	

11. AC Timing Diagram

11.1.1 Clock and Data Input Timing Diagram

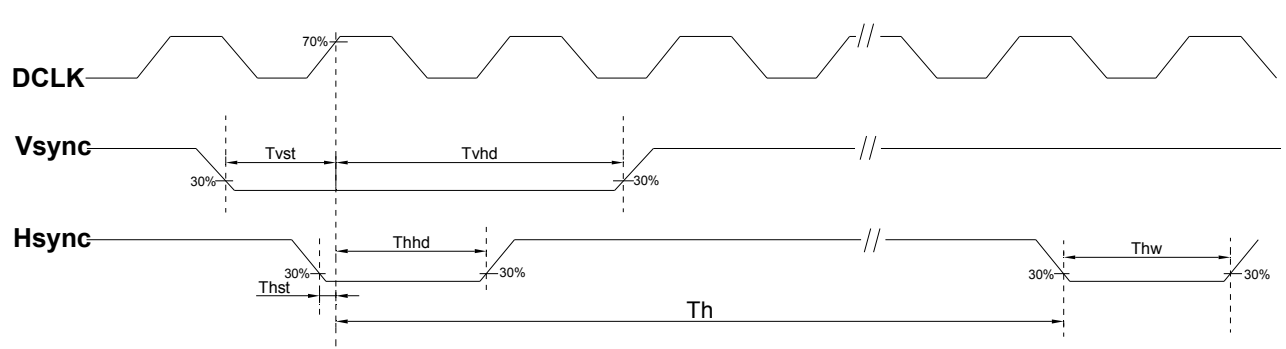
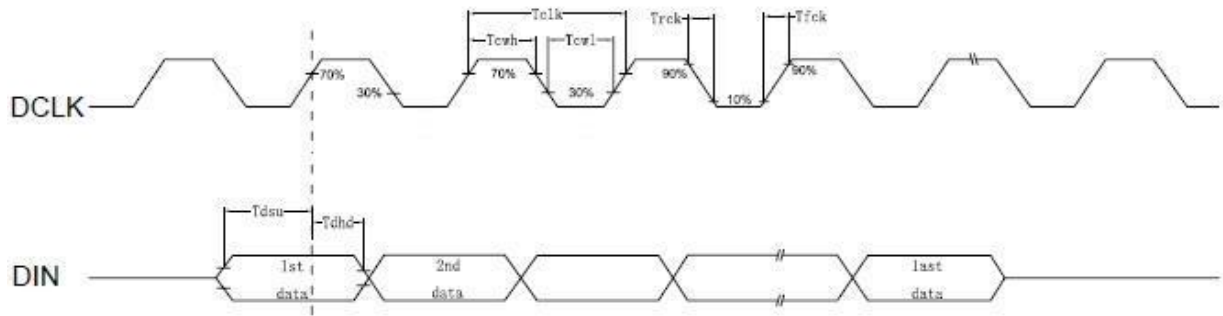

12. INPUT DATA FORMAT

12.1 Parallel RGB Data Format

12.1.1 Parallel RGB Input Timing Table

Item	System	Min.	Typ.	Max.	Unit		
DCLK Frequency	Fclk	-	10.7	-	MHz		
Hsync	Period Time	Th	-	531	-	DCLK	
	Display Period	Thdisp	-	480	-	DCLK	
	Back Porch	Thbp	-	43	-	DCLK	By H_BLANKING setting
	Front Porch	Thfp	-	8	-	DCLK	
	Pulse Width	Thw	-	2	-	DCLK	
Vsync	Period Time	Tv	-	288	-	H	
	Display Period	Tvdisp	-	272	-	H	
	Back Porch	Tvbp	-	12	-	H	By V_BLANKING setting
	Front Porch	Tvfp	-	4	-	H	
	Pulse Width	Tvw	-	10	-	H	

12.1.2 SYNC Mode Timing Diagram

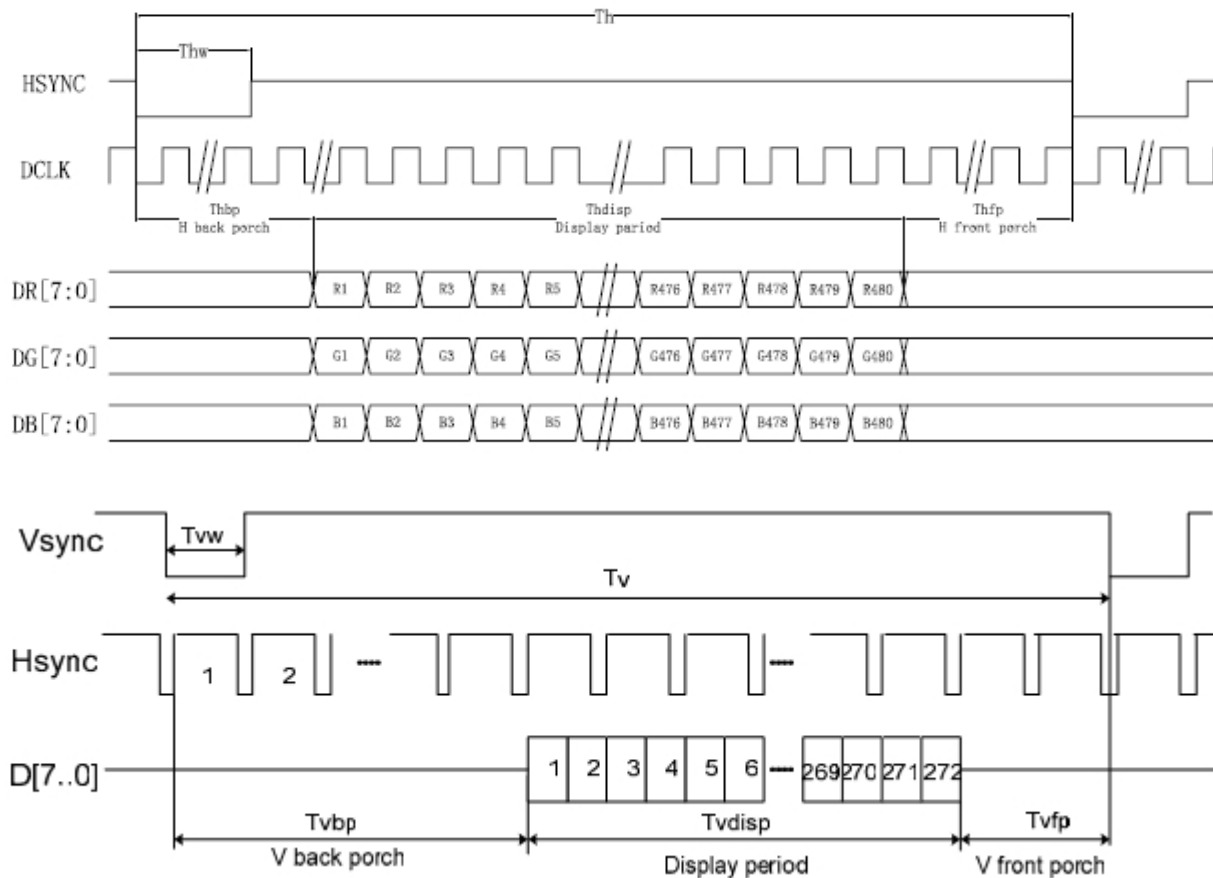

13. Quality Assurance

13.1 Purpose

This standard for Quality Assurance assures the quality of LCD module products supplied to customer.

13.2 Standard for Quality Test

13.2.1 Sampling Plan:

GB2828.1-2012

Single sampling, general inspection level II.

13.2.2 Sampling Criteria:

Visual inspection: AQL 1.5%

Electrical functional: AQL 0.65%.

13.2.3 Reliability Test:

Detailed requirement refer to Reliability Test Specification.

13.3 Nonconforming Analysis & Disposition

13.3.1 Nonconforming analysis:

13.3.1.1 Customer should provide overall information of non-conforming sample for their complaints.

13.3.1.2 After receipt of detailed information from customer, the analysis of nonconforming parts usually should be finished in one week.

13.3.1.3 If cannot finish the analysis on time, customer will be notified with the progress status.

13.3.2 Disposition of nonconforming:

13.3.2.1 Non-conforming product over PPM level will be replaced.

13.3.2.2 The cause of non-conformance will be analyzed. Corrective action will be discussed and implemented.

13.4 Agreement Items

Shall negotiate with customer if the following situation occurs:

13.4.1 There is any discrepancy in standard of quality assurance.

13.4.2 Additional requirement to be added in product specification.

13.4.3 Any other special problem.

13.5 Standard of the Product Visual Inspection

13.5.1 Appearance inspection:

13.5.1.1 The inspection must be under illumination about 1000 – 1500 lx, and the distance of view must be at 30cm ± 2cm.

13.5.1.2 The viewing angle should be 45° from the vertical line without reflection light or follows customer's viewing angle specifications.

13.5.1.3 Definition of area: A Zone: Active Area, B Zone: Viewing Area,

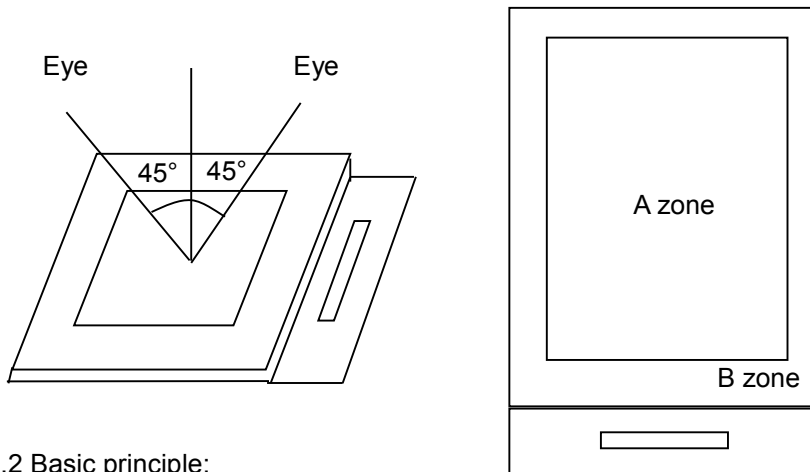

13.5.2 Basic principle:

13.5.2.1 A set of sample to indicate the limit of acceptable quality level must be discussed by both us and customer when there is any dispute happened.

13.5.2.2 New item must be added on time when it is necessary.

13.6 Inspection Specification

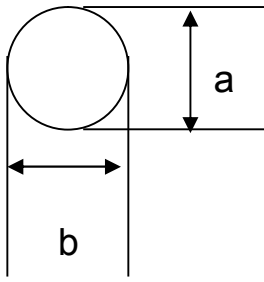
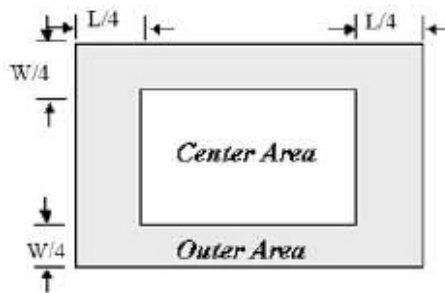
No.	Item	Criteria (Unit: mm)																		
01	Black / White spot Foreign material (Round type) Pinholes Stain Particles inside cell. (Minor defect)	 <table border="1" data-bbox="877 347 1412 649"> <thead> <tr> <th>Size \ Area</th> <th>Acc. Qty</th> </tr> </thead> <tbody> <tr> <td>$\phi \leq 0.10$</td> <td>Ignore</td> </tr> <tr> <td>$0.10 < \phi \leq 0.15$</td> <td>2</td> </tr> <tr> <td>$0.15 < \phi \leq 0.25$</td> <td>1</td> </tr> <tr> <td>$0.25 < \phi$</td> <td>0</td> </tr> <tr> <td>Total</td> <td>2 no include $\phi \leq 0.10$</td> </tr> </tbody> </table> <p>$\phi = (a + b) / 2$ Distance between 2 defects should more than 3mm apart.</p>	Size \ Area	Acc. Qty	$\phi \leq 0.10$	Ignore	$0.10 < \phi \leq 0.15$	2	$0.15 < \phi \leq 0.25$	1	$0.25 < \phi$	0	Total	2 no include $\phi \leq 0.10$						
Size \ Area	Acc. Qty																			
$\phi \leq 0.10$	Ignore																			
$0.10 < \phi \leq 0.15$	2																			
$0.15 < \phi \leq 0.25$	1																			
$0.25 < \phi$	0																			
Total	2 no include $\phi \leq 0.10$																			
02	Electrical Defect (Minor defect)	<table border="1" data-bbox="518 739 1380 996"> <thead> <tr> <th>Bright dot</th> <th>Display Area</th> <th>Total</th> <th rowspan="3">Note1</th> </tr> </thead> <tbody> <tr> <td></td> <td>$N \leq 2$</td> <td>$N \leq 2$</td> </tr> <tr> <th>Dark dot</th> <td>$N \leq 4$</td> <td>$N \leq 4$</td> </tr> <tr> <th>Total dot</th> <td>$N \leq 4$</td> <td>$N \leq 4$</td> <td></td> </tr> <tr> <th>Mura</th> <td colspan="2">Not visible through 5% ND filters.</td> <th>Note 2</th> </tr> </tbody> </table> <p>Remark: 1. Bright dot caused by scratch and foreign object accords to item 1.</p>	Bright dot	Display Area	Total	Note1		$N \leq 2$	$N \leq 2$	Dark dot	$N \leq 4$	$N \leq 4$	Total dot	$N \leq 4$	$N \leq 4$		Mura	Not visible through 5% ND filters.		Note 2
Bright dot	Display Area	Total	Note1																	
	$N \leq 2$	$N \leq 2$																		
Dark dot	$N \leq 4$	$N \leq 4$																		
Total dot	$N \leq 4$	$N \leq 4$																		
Mura	Not visible through 5% ND filters.		Note 2																	
03	Inactive Area (Minor defect)	<p>Line Criteria: $L \leq 1\text{mm}, W \leq 0.1\text{mm}$, Dot Criteria: Please refer to Note 1,2&3 Note1: Definition of Area</p>  <p>Note 2:</p> <table border="1" data-bbox="518 1601 1364 1780"> <thead> <tr> <th>Size</th> <th>Inactive dot</th> <th>Center</th> <th>Outer</th> <th>Total</th> <th>Remark</th> </tr> </thead> <tbody> <tr> <td>All</td> <td>$\phi < 0.2\text{mm}$</td> <td colspan="4">Is not counted</td> </tr> <tr> <td><6"</td> <td>$0.2 \leq \phi \leq 0.3\text{mm}$ $L \leq 1\text{mm}, W \leq 0.1\text{mm}$</td> <td>$N \leq 1$</td> <td>$N \leq 2$</td> <td>$N \leq 3$</td> <td></td> </tr> </tbody> </table> <p>Note3: Inactive area $D < 0.2\text{mm}$ is not counted without appearance observation. Remark: Effective area is from the POL cutting side to 0.5mm of inside. This is no count area. Other part is effective area. In no count area, any defect can ignore. In effective area, have to judge from above-mentioned specification.</p>	Size	Inactive dot	Center	Outer	Total	Remark	All	$\phi < 0.2\text{mm}$	Is not counted				<6"	$0.2 \leq \phi \leq 0.3\text{mm}$ $L \leq 1\text{mm}, W \leq 0.1\text{mm}$	$N \leq 1$	$N \leq 2$	$N \leq 3$	
Size	Inactive dot	Center	Outer	Total	Remark															
All	$\phi < 0.2\text{mm}$	Is not counted																		
<6"	$0.2 \leq \phi \leq 0.3\text{mm}$ $L \leq 1\text{mm}, W \leq 0.1\text{mm}$	$N \leq 1$	$N \leq 2$	$N \leq 3$																

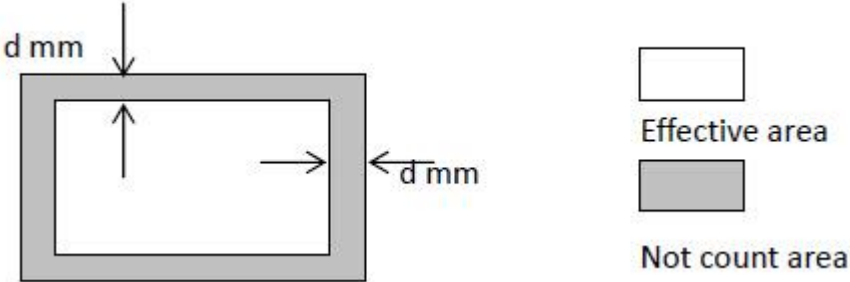
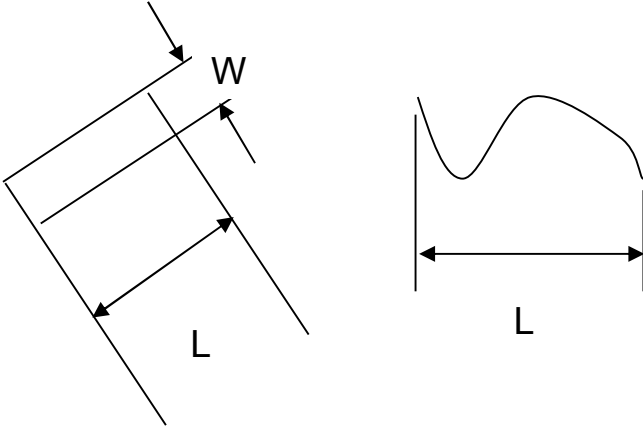
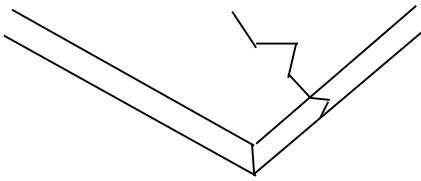
																				
<p>04</p>	<p>Black and White line Scratch Foreign material (Line type) (Minor defect)</p>	 <table border="1" data-bbox="579 1193 1206 1496"> <thead> <tr> <th>Length</th> <th>Width</th> <th>Acc. Qty</th> </tr> </thead> <tbody> <tr> <td>/</td> <td>$W \leq 0.03$</td> <td>Ignore</td> </tr> <tr> <td>$L \leq 2.5$</td> <td>$0.03 < W \leq 0.05$</td> <td>3</td> </tr> <tr> <td>$L \leq 2.5$</td> <td>$0.05 < W \leq 0.10$</td> <td>2</td> </tr> <tr> <td>/</td> <td>$0.1 < W$</td> <td>0</td> </tr> <tr> <td colspan="2">Total</td> <td>3</td> </tr> </tbody> </table> <p>Distance between 2 defects should more than 3mm apart. Scratches not viewable through the back of the display are acceptable.</p>	Length	Width	Acc. Qty	/	$W \leq 0.03$	Ignore	$L \leq 2.5$	$0.03 < W \leq 0.05$	3	$L \leq 2.5$	$0.05 < W \leq 0.10$	2	/	$0.1 < W$	0	Total		3
Length	Width	Acc. Qty																		
/	$W \leq 0.03$	Ignore																		
$L \leq 2.5$	$0.03 < W \leq 0.05$	3																		
$L \leq 2.5$	$0.05 < W \leq 0.10$	2																		
/	$0.1 < W$	0																		
Total		3																		
<p>05</p>	<p>Glass Crack (Minor defect)</p>	 <p>Crack is potential to enlarge, any type is not allowed.</p>																		

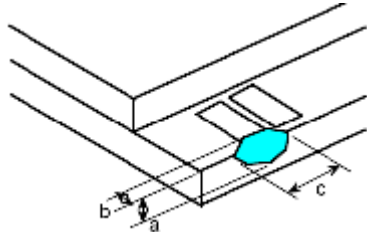
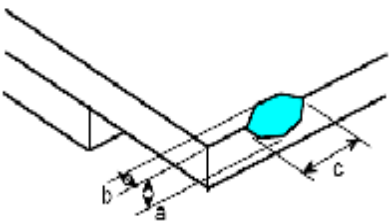
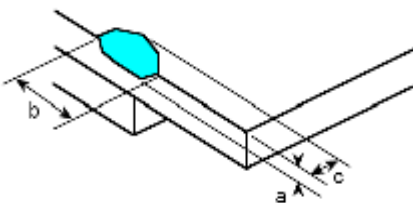
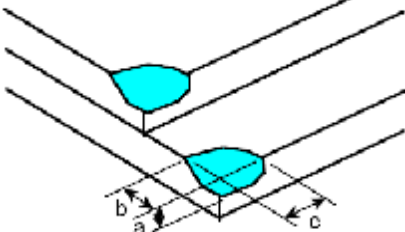
<p>06</p>	<p>Glass Chipping Pad Area: (Minor defect)</p> 	<table border="1"> <thead> <tr> <th>Length and Width</th> <th>Acc. Qty</th> </tr> </thead> <tbody> <tr> <td>$c > 3.0, b < 1.0$</td> <td>1</td> </tr> <tr> <td>$c < 3.0, b < 1.0$</td> <td>3</td> </tr> <tr> <td colspan="2">$a < \text{Glass Thickness}$</td> </tr> </tbody> </table>	Length and Width	Acc. Qty	$c > 3.0, b < 1.0$	1	$c < 3.0, b < 1.0$	3	$a < \text{Glass Thickness}$			
Length and Width	Acc. Qty											
$c > 3.0, b < 1.0$	1											
$c < 3.0, b < 1.0$	3											
$a < \text{Glass Thickness}$												
<p>07</p>	<p>Glass Chipping Rear of Pad Area: (Minor defect)</p> 	<table border="1"> <thead> <tr> <th>Length and Width</th> <th>Acc. Qty</th> </tr> </thead> <tbody> <tr> <td>$c > 3.0, b < 1.0$</td> <td>1</td> </tr> <tr> <td>$c < 3.0, b < 1.0$</td> <td>2</td> </tr> <tr> <td>$c < 3.0, b < 0.5$</td> <td>4</td> </tr> <tr> <td colspan="2">$a < \text{Glass Thickness}$</td> </tr> </tbody> </table>	Length and Width	Acc. Qty	$c > 3.0, b < 1.0$	1	$c < 3.0, b < 1.0$	2	$c < 3.0, b < 0.5$	4	$a < \text{Glass Thickness}$	
Length and Width	Acc. Qty											
$c > 3.0, b < 1.0$	1											
$c < 3.0, b < 1.0$	2											
$c < 3.0, b < 0.5$	4											
$a < \text{Glass Thickness}$												
<p>08</p>	<p>Glass Chipping Except Pad Area: (Minor defect)</p> 	<table border="1"> <thead> <tr> <th>Length and Width</th> <th>Acc. Qty</th> </tr> </thead> <tbody> <tr> <td>$c > 3.0, b < 1.0$</td> <td>1</td> </tr> <tr> <td>$c < 3.0, b < 1.0$</td> <td>2</td> </tr> <tr> <td>$c < 3.0, b < 0.5$</td> <td>4</td> </tr> <tr> <td colspan="2">$a < \text{Glass Thickness}$</td> </tr> </tbody> </table>	Length and Width	Acc. Qty	$c > 3.0, b < 1.0$	1	$c < 3.0, b < 1.0$	2	$c < 3.0, b < 0.5$	4	$a < \text{Glass Thickness}$	
Length and Width	Acc. Qty											
$c > 3.0, b < 1.0$	1											
$c < 3.0, b < 1.0$	2											
$c < 3.0, b < 0.5$	4											
$a < \text{Glass Thickness}$												
<p>09</p>	<p>Glass Corner Chipping: (Minor defect)</p> 	<table border="1"> <thead> <tr> <th>Length and Width</th> <th>Acc. Qty</th> </tr> </thead> <tbody> <tr> <td>$c < 3.0, b < 3.0$</td> <td>Ignore</td> </tr> <tr> <td colspan="2">$a < \text{Glass Thickness}$</td> </tr> </tbody> </table>	Length and Width	Acc. Qty	$c < 3.0, b < 3.0$	Ignore	$a < \text{Glass Thickness}$					
Length and Width	Acc. Qty											
$c < 3.0, b < 3.0$	Ignore											
$a < \text{Glass Thickness}$												

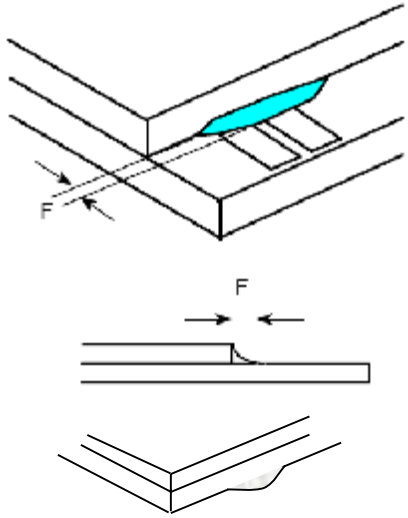
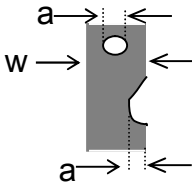
<p>10</p>	<p>Glass Burr: (Minor defect)</p> 	<table border="1" data-bbox="866 264 1337 353"> <thead> <tr> <th>Length</th> <th>Acc. Qty</th> </tr> </thead> <tbody> <tr> <td>F < 1.0</td> <td>Ignore</td> </tr> </tbody> </table> <p>Glass burr don't affect assemble and module dimension.</p>	Length	Acc. Qty	F < 1.0	Ignore						
Length	Acc. Qty											
F < 1.0	Ignore											
<p>11</p>	<p>FPC Defect: (Minor defect)</p> 	<p>11.1 Dent, pinhole width $a < w/3$. (w: circuitry width.) 11.2 Open circuit is unacceptable. 11.3 No oxidation, contamination and distortion.</p>										
<p>12</p>	<p>Bubble on Polarizer (Minor defect)</p>	<table border="1" data-bbox="743 1301 1214 1514"> <thead> <tr> <th>Diameter</th> <th>Acc. Qty</th> </tr> </thead> <tbody> <tr> <td>$\varphi \leq 0.20$</td> <td>Ignore</td> </tr> <tr> <td>$0.20 < \varphi \leq 0.30$</td> <td>4</td> </tr> <tr> <td>$0.30 < \varphi \leq 0.50$</td> <td>1</td> </tr> <tr> <td>$0.50 < \varphi$</td> <td>None</td> </tr> </tbody> </table>	Diameter	Acc. Qty	$\varphi \leq 0.20$	Ignore	$0.20 < \varphi \leq 0.30$	4	$0.30 < \varphi \leq 0.50$	1	$0.50 < \varphi$	None
Diameter	Acc. Qty											
$\varphi \leq 0.20$	Ignore											
$0.20 < \varphi \leq 0.30$	4											
$0.30 < \varphi \leq 0.50$	1											
$0.50 < \varphi$	None											
<p>13</p>	<p>Dent on Polarizer (Minor defect)</p>	<table border="1" data-bbox="743 1574 1214 1787"> <thead> <tr> <th>Diameter</th> <th>Acc. Qty</th> </tr> </thead> <tbody> <tr> <td>$\varphi \leq 0.20$</td> <td>Ignore</td> </tr> <tr> <td>$0.20 < \varphi \leq 0.30$</td> <td>4</td> </tr> <tr> <td>$0.30 < \varphi \leq 0.50$</td> <td>1</td> </tr> <tr> <td>$0.50 < \varphi$</td> <td>None</td> </tr> </tbody> </table>	Diameter	Acc. Qty	$\varphi \leq 0.20$	Ignore	$0.20 < \varphi \leq 0.30$	4	$0.30 < \varphi \leq 0.50$	1	$0.50 < \varphi$	None
Diameter	Acc. Qty											
$\varphi \leq 0.20$	Ignore											
$0.20 < \varphi \leq 0.30$	4											
$0.30 < \varphi \leq 0.50$	1											
$0.50 < \varphi$	None											
<p>14</p>	<p>Bezel</p>	<p>14.1 No rust, distortion on the Bezel. 14.2 No visible fingerprints, stains or other contamination.</p>										

15	Touch Panel	<p>D: Diameter W: width L: length</p> <p>15.1 Spot: $D < 0.25$ is acceptable $0.25 \leq D \leq 0.4$</p> <p>2dots are acceptable and the distance between defects should more than 10 mm.</p> <p>$D > 0.4$ is unacceptable</p> <p>15.2 Dent: $D > 0.40$ is unacceptable</p> <p>15.3 Scratch: $W \leq 0.03$, $L \leq 10$ is acceptable, $0.03 < W \leq 0.10$, $L \leq 10$ is acceptable</p> <p>Distance between 2 defects should more than 10 mm. $W > 0.10$ is unacceptable.</p>
16	LCD Ripple	<p>Touch the touch panel, cannot see the LCD ripple.</p> <p>Pen: R 0.8mm silicon rubber.</p> <p>Operation Force:100g</p>
17	PCB	<p>17.1 No distortion or contamination on PCB terminals.</p> <p>17.2 All components on PCB must same as documented on the BOM/component layout.</p> <p>17.3 Follow IPC-A-600F.</p>
18	Soldering	<p>Follow IPC-A-610C standard</p>
19	Electrical Defect (Major defect)	<p>The below defects must be rejected.</p> <p>19.1 Missing vertical / horizontal segment,</p> <p>19.2 Abnormal Display.</p> <p>19.3 No function or no display.</p> <p>19.4 Current exceeds product specifications.</p> <p>19.5 LCD viewing angle defect.</p> <p>19.6 No Backlight.</p> <p>19.7 Dark Backlight.</p> <p>19.8 Touch Panel no function.</p>

Remark: LCD Panel Broken shall be rejected. Defect out of LCD viewing area is acceptable.

13.7 Classification of Defects

13.7.1 Visual defects (Except no / wrong label) are treated as minor defect and electrical defect is major.

13.7.2 Two minor defects are equal to one major in lot sampling inspection.

13.8 Identification/marketing criteria

Any unit with illegible / wrong /double or no marking/ label shall be rejected.

13.9 Packaging

13.9.1 There should be no damage of the outside carton box, each packaging box should have one identical label.

13.9.2 Modules inside package box should have compliant mark.

13.9.3 All direct package materials shall offer ESD protection

Note1: Bright dot is defined as the defective area of the dot is larger than 50% of one sub-pixel area.

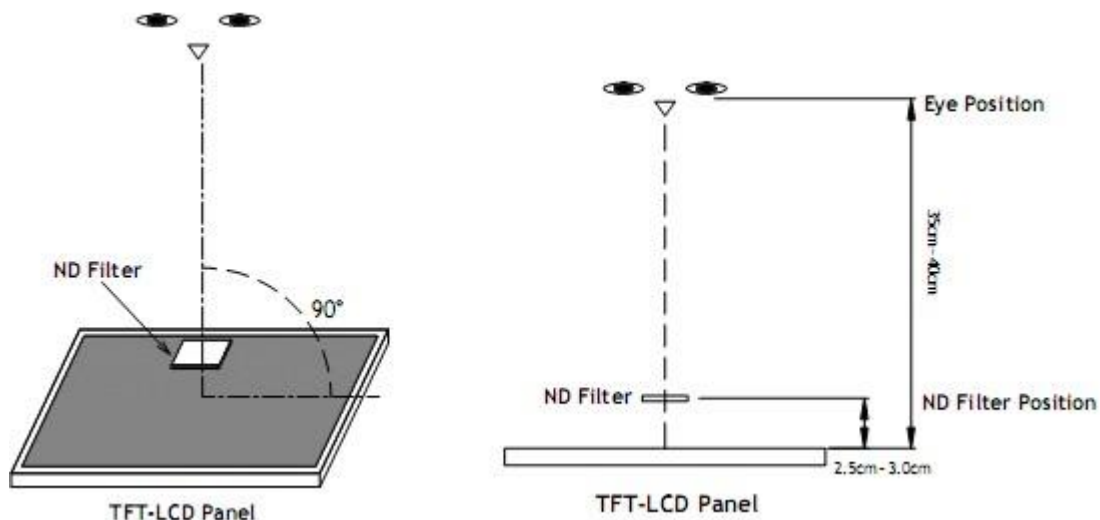

Bright dot: The bright dot size defect at black display pattern. It can be recognized by 2% transparency of filter when the distance between eyes and panel is 350mm±50mm.

Dark dot: Cyan, Magenta or Yellow dot size defect at white display pattern. It can be recognized by 5% transparency of filter when the distance between eyes and panel is 350mm±50mm.

Note2: Mura on display which appears darker / brighter against background brightness on parts of display area.

14. Reliability Specification

No	Item	Condition	Quantity	Criteria
1	High Temperature Operating	70°C, 96Hrs	2	GB/T2423.2-2008
2	Low Temperature Operating	-20°C, 96Hrs	2	GB/T2423.1-2008
3	High Humidity	50°C, 90%RH, 96Hrs	2	GB/T2423.3-2006
4	High Temperature Storage	80°C, 96Hrs	2	GB/T2423.2-2008
5	Low Temperature Storage	-30°C, 96Hrs	2	GB/T2423.1-2008
6	Thermal Cycling Test	-20°C, 60min~70°C, 60min, 20 cycles.	2	GB/T2423.22-2012
7	Packing vibration	Frequency range:10Hz~50Hz Acceleration of gravity:5G X, Y, Z 30 min for each direction.	2	GB/T5170.14-2009
8	Electrical Static Discharge	Air: ±8KV 150pF/330Ω 5 times Contact: ±4KV 150pF/330Ω 5 times	2	GB/T17626.2-2006
9	Drop Test (Packaged)	Height:80 cm,1 corner, 3 edges, 6 surfaces.	2	GB/T2423.8-1995

Note1. No defection cosmetic and operational function allowable.

Note2. Total current Consumption should be below double of initial value.

15. Precautions and Warranty

15.1 Safety

15.1.1 The liquid crystal in the LCD is poisonous. Do not put it in your mouth. If the liquid crystal touches your skin or clothes, wash it off immediately using soap and water.

15.1.2 Since the liquid crystal cells are made of glass, do not apply strong impact on them. Handle with care.

15.2 Handling

15.2.1 Reverse and use within ratings in order to keep performance and prevent damage.

15.2.2 Do not wipe the polarizer with dry cloth, as it might cause scratch. If the surface of the LCD needs to be cleaned, wipe it swiftly with cotton or other soft cloth soaked with petroleum IPA, do not use other chemicals.

15.3 Storage

15.3.1 Do not store the LCD module beyond the specified temperature ranges.

15.4 Metal Pin (Apply to Products with Metal Pins)

15.4.1 Pins of LCD and Backlight

15.4.1.1 Solder tip can touch and press on the tip of Pin LEAD during the soldering

15.4.1.2 Recommended Soldering Conditions

Solder Type: Sn96.3~94-Ag3.3~4.3-Cu0.4~1.1

Maximum Solder Temperature: 370℃

Maximum Solder Time: 3s at the maximum temperature

Recommended Soldering Temp: 350±20℃

Typical Soldering Time: ≤3s

15.4.1.3 Solder Wetting

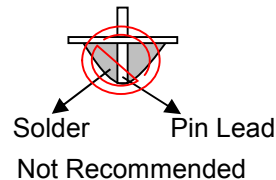
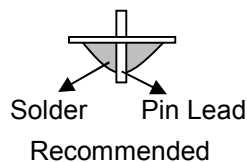

15.4.2 Pins of EL

15.4.2.1 Solder tip can touch and press on the tip of EL leads during soldering.

15.4.2.2 No Solder Paste on the soldering pad on the motherboard is recommended.

15.4.2.3 Recommended Soldering Conditions

Solder type: Nippon Alimit Leadfree SR-34, size 0.5mm

Recommended Solder Temperature: 270~290℃

Typical Soldering Time: ≤2s

Minimum solder distance from EL lamp (body):2.0mm

15.4.2.4 No horizontal press on the EL leads during soldering.

15.4.2.5 180° bend EL leads three times is not allowed.

15.4.2.6 Solder Wetting

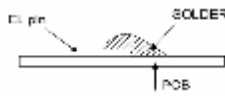

Recommended

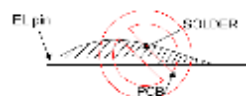

Not Recommended

15.4.2.7 The type of the solder iron:

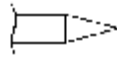

Recommended

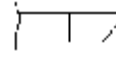

Not Recommended

15.4.2.8 Solder Pad

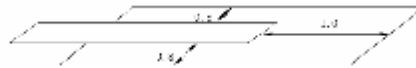

15.5 Operation

15.5.1 Do not drive LCD with DC voltage

15.5.2 Response time will increase below lower temperature

15.5.3 Display may change color with different temperature

15.5.4 Mechanical disturbance during operation, such as pressing on the display area, may cause the segments to appear “fractured”.

15.6 Static Electricity

15.6.1 CMOS LSIs are equipped in this unit, so care must be taken to avoid the electro-static charge, by ground human body, etc.

15.6.2 The normal static prevention measures should be observed for work clothes and benches.

15.6.3 The module should be kept into anti-static bags or other containers resistant to static for storage.

15.7 Limited Warranty

15.7.1 Our warranty liability is limited to repair and/or replacement. We will not be responsible for any consequential loss.

15.7.2 If possible, we suggest customer to use up all modules in six months. If the module storage time over twelve months, we suggest that recheck it before the module be used.

15.7.3 After the product shipped, any product quality issues must be feedback within three months, otherwise, we will not be responsible for the subsequent or consequential events.

16. Outline Drawing

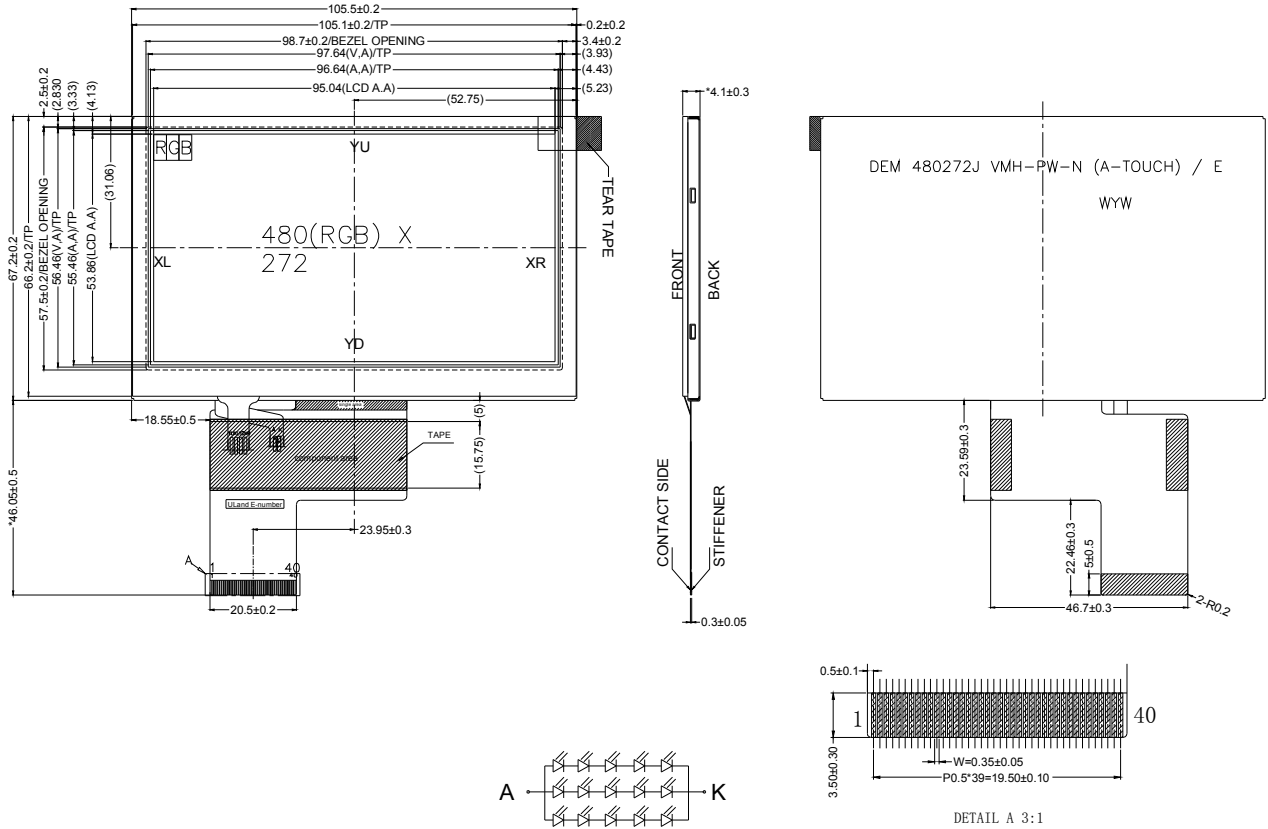

- NOTES:
1. Display Size: 4,3" TFT
 2. Viewing Direction: FULL VIEW
 3. Display Mode: MVA, Transmissive / Normal White / Anti-Glare
 4. Operation Temperature: -20°C to +70°C
 5. Storage Temperature: -30°C to +80°C
 6. Driver IC: Orisetech, OTA5180A
 7. Power Supply Voltage: 3.3 Volt (typ.)
 8. Backlight: White (15xLEDs), 16.0Volt / 60mA (typ.)
 9. Luminance: 330cd/m2 (typ.)
 10. LED Lifetime: 30000h (typ.)
 11. ROHS must be complied
 12. Unspecification tolerance are±0.2mm

PIN	SYMBOL	Pin assignment
1	VLED-	
2	VLED+	
3	GND	
4	VD	
5	R0	
6	R1	
7	R2	
8	R3	
9	R4	
10	R6	
11	R6	
12	R7	
13	G0	
14	G1	
15	G2	
16	G3	
17	G4	
18	G5	
19	G6	
20	G7	
21	B0	
22	B1	
23	B2	
24	B3	
25	B4	
26	B5	
27	B6	
28	B7	
29	GND	
30	PCLK	
31	DISP	
32	HSYNC	
33	VSYNC	
34	DE	
35	NC	
36	GND	
37	XR	
38	YD	
39	XL	
40	YU	