

Display Elektronik GmbH

DATA SHEET

TFT MODULE

DEM 480128A VMH-PW-N (A-TOUCH)

3,9" TFT + Touch

Product Specification

Ver.: 1

13.09.2017

Revision History

Revision	Date	Originator	Detail	Remarks
0	15.08.2017	MH	Initial Release	-
1	13.09.2017	MH	Add Weight Add Chromaticity	P4 P7

Table of Contents

1. General Description 4

2. Module Parameter 4

3. Absolute Maximum Ratings 4

4. DC Characteristics 5

5. Backlight Characteristic 5

 5.1. Backlight Characteristics 5

 5.2. Backlighting circuit 5

6. Touch Screen Panel Specifications 6

7. Optical Characteristics 7

 7.1. Optical Characteristics 7

 7.2. Definition of Response Time 7

 7.3. Definition of Contrast Ratio 8

 7.4. Definition of Viewing Angles 8

 7.5. Definition of Color Appearance 9

 7.6. Definition of Surface Luminance, Uniformity and Transmittance 9

8. Block Diagram and Power Supply 10

9. Interface Pins Definition 11

10. AC Characteristics 12

11. INPUT DATA FORMAT 13

12. Quality Assurance 14

 12.1 Purpose 14

 12.2 Standard for Quality Test 14

 12.3 Nonconforming Analysis & Disposition 14

 12.4 Agreement Items 14

 12.5 Standard of the Product Visual Inspection 15

 12.6 Inspection Specification 15

 12.7 Classification of Defects 21

 12.8 Identification/marketing criteria 21

 12.9 Packing 21

13. Reliability Specification 22

14. Precautions and Warranty 23

 14.1 Safety 23

 14.2 Handling 23

 14.3 Storage 23

 14.4 Metal Pin (Apply to Products with Metal Pins) 23

 14.5 Operation 24

 14.6 Static Electricity 24

 14.7 Limited Warranty 24

15. Outline Drawing 25

1. General Description

The specification is a transmissive type color active matrix liquid crystal display (LCD) which uses amorphous thin film transistor (TFT) as switching devices. This product is composed of a TFT-LCD panel, driver ICs, a touch panel and a backlight unit.

2. Module Parameter

Features	Details	Unit
Display Size(Diagonal)	3.9"	-
LCD Type	TN TFT	-
Display Mode	Transmissive /Normally white	-
Resolution	480 x RGB x 128	Pixels
View Direction	12 O'clock	Best Image
Gray Scale Inversion Direction	6 O'clock	-
Module Outline	105.50 x 40.64 x 4.10 (Note1)	mm
Active Area	95.04 x 25.34	mm
Pixel Pitch	0.198 x 0.198	um
Pixel Arrangement	Stripe	-
Polarizer Surface Treatment	Anti-Glare	-
Display Colors	16 Million	-
Interface	24-Bit-RGB-Interface	-
Driver IC	OTA5180A	-
With or Without Touch Panel	With 4-Wire-Resistive-Touch	-
Operating Temperature	-20°C to +70°C	°C
Storage Temperature	-30°C to +80°C	°C
Weight	~ 36	g

Note 1: Exclusive hooks, posts, FFC/FPC tail etc.

3. Absolute Maximum Ratings

$V_{SS}=0V$, $T_a=25^{\circ}C$

Item	Symbol	Min.	Max.	Unit
Supply Voltage	VCC	-0.3	4.5	V
Storage Temperature	T _{STG}	-30	+80	°C
Operating Temperature	T _{OP}	-20	+70	°C

Note 1: If T_a below +50°C, the maximal humidity is 90%RH, if T_a over +50°C, absolute humidity should be less than 60%RH.

Note 2: The response time will be extremely slow when the operating temperature is around -10°C, and the back ground will become darker at high temperature operating.

4. DC Characteristics

Item	Symbol	Min.	Typ.	Max.	Unit	
Digital Interface Supply Voltage	VCC	3.0	3.3	3.6	V	
Logic Low Input Voltage	V _{IL}	GND	-	0.3*VCC	V	
Logic High Input Voltage	V _{IH}	0.7*VCC	-	VCC	V	
Logic Low Output Voltage	V _{OL}	GND	-	GND+0.4	V	
Logic High Output Voltage	V _{OH}	VCC-0.4	-	VCC	V	
Current Consumption All Black	Logic Analog	I _{CC} + I _{IN}	-	(10)	-	mA

5. Backlight Characteristic

5.1. Backlight Characteristics

Item	Symbol	Condition	Min.	Typ.	Max.	Unit
Forward Voltage	V _F	Ta=25 °C, I _F =20mA/LED	16.8	19.2	20.4	V
Forward Current	I _F	Ta=25 °C, V _F =3.2V/LED	-	40	-	mA
Power Dissipation	P _D		-	768	-	mW
LED Lifetime (+25°C)	-	-	20000	30000	-	Hr
Uniformity	Avg		-	80	-	%
Drive Method	Constant Current					
LED Configuration	12 White LEDs (6 LEDs in one string and 2 groups in parallel)					

Note: LED life time defined as follows: The final brightness is at 70% of original brightness.

The environmental conducted under ambient air flow, at Ta=+25°C±2°C, 60%RH±5%,
I_F ≤ 20mA.

5.2. Backlighting Circuit

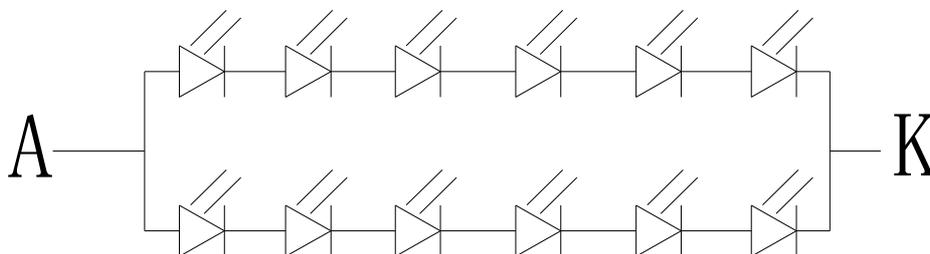

6. Touch Screen Panel Specifications**6.1 Electrical Characteristics**

Item	Min.	Typ.	Max.	Unit	Note
Linearity	-1.5	-	1.5	%	Analog X and Y directions
Terminal Resistance	800	-	1950	Ω	X (Film side)
	30	-	300	Ω	Y (Glass side)
Voltage	-	-	5	V	DC
Chattering	-	-	15	ms	

Caution (1): Do not operate it with a thing except a polyacetal pen (tip R0.8mm or less) or a finger, especially those with hard or sharp tips such as a ball point pen or a mechanical pencil.

6.2 Mechanical & Reliability Characteristics

Item	Min.	Typ.	Max.	Unit	Note
Activation Force	-	-	100	g	(1)
Durability-Surface Scratching	Write 20,000	-	-	characters	(2)
Durability-Surface Pitting	1,000,000	-	-	touches	(3)
Surface Hardness	3	-	-	H	

Note (1) Stylus pen Input: R0.8mm polyacetal pen or Finger

Note (2) Measurement for Surface area - Scratch 100,000 times straight line on the Film with a stylus change every 20,000times

- Force: 150-250gf
- Speed: 60mm/sec
- Stylus: R0.8 polyacetal pen or Finger

Note (3) Pit 1,000,000 times on the Film with a R3.75 silicon rubber.

- Force: Force: 2.45N
- Speed: 3times/sec

7. Optical Characteristics

7.1. Optical Characteristics

Ta=25°C, VCC=3.3V, TN LC+ Polarizer

Item	Symbol	Condition	Specification			Unit
			Min.	Typ.	Max.	
Luminance on TFT($I_f=20\text{mA/LED}$)	Lv	Normally viewing angle $\theta_x = \phi_y = 0^\circ$	380	480	-	cd/m ²
Contrast ratio(See 6.3)	CR		300	500	-	
Response time (See 6.2)	TR+TF		-	30	45	ms
Chromaticity Transmissive (See 6.5)	Red	XR	0.575	0.625	0.675	
		YR	0.305	0.355	0.405	
	Green	XG	0.284	0.334	0.384	
		YG	0.550	0.600	0.650	
	Blue	XB	0.100	0.150	0.200	
		YB	0.074	0.124	0.174	
	White	XW	0.246	0.296	0.346	
		YW	0.292	0.342	0.392	
Viewing Angle (See 6.4)	Horizontal	θ_{x+}	55	70	-	Deg.
		θ_{x-}	55	70	-	
	Vertical	ϕ_{y+}	55	70	-	
		ϕ_{y-}	55	70	-	
NTSC Ratio(Gamut)			-	50	-	%

7.2. Definition of Response Time

7.2.1. Normally Black Type (Negative)

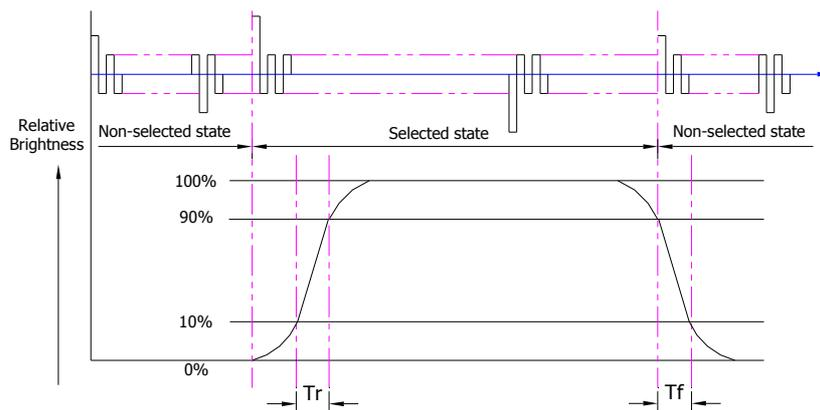

Tr is the time it takes to change from non-selected stage with relative luminance 10% to selected state with relative luminance 90%;

Tf is the time it takes to change from selected state with relative luminance 90% to non-selected state with relative luminance 10%.

Note : Measuring machine: LCD-5100

7.2.2. Normally White Type (Positive)

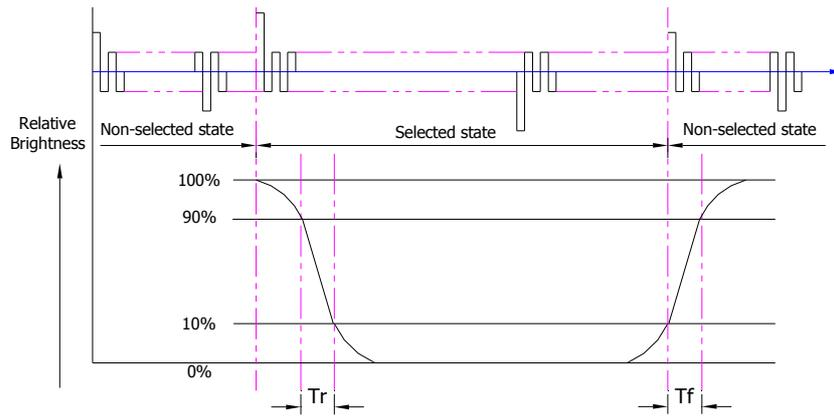

Tr is the time it takes to change from non-selected state with relative luminance 90% to selected state with relative luminance 10%;

Tf is the time it takes to change from selected state with relative luminance 10% to non-selected state with relative luminance 90%;

Note : Measuring machine: LCD-5100 or EQUI

7.3. Definition of Contrast Ratio

Contrast is measured perpendicular to display surface in reflective and transmissive mode.

The measurement condition is:

Measuring Equipment	Eldim or Equivalent
Measuring Point Diameter	3mm//1mm
Measuring Point Location	Active Area centre point
Test pattern	A: All Pixels white
	B: All Pixel black
Contrast setting	Maximum

Definitions: CR (Contrast) = Luminance of White Pixel / Luminance of Black Pixel

7.4. Definition of Viewing Angles

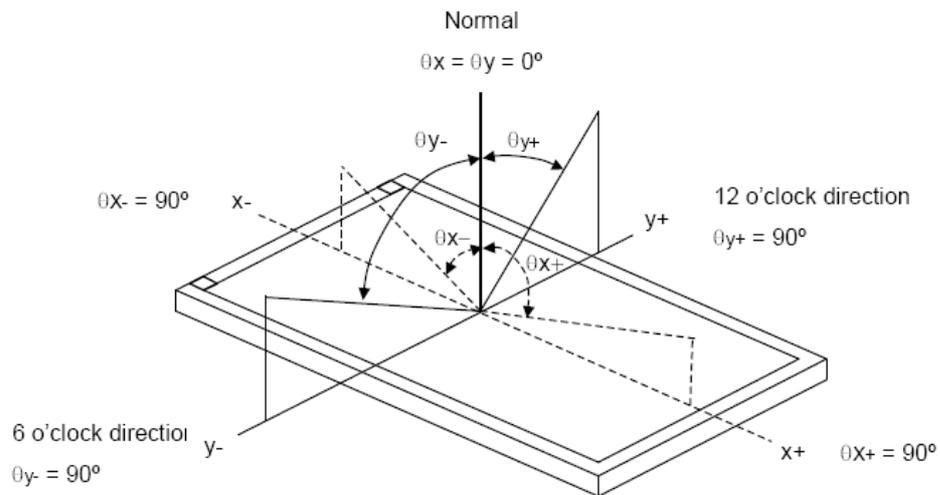

Measuring machine: LCD-5100 or EQUI

7.5. Definition of Color Appearance

R,G,B and W are defined by (x, y) on the IE chromaticity diagram

NTSC=area of RGB triangle/area of NTSC triangleX100%

Measuring picture: Red, Green, Blue and White (Measuring machine: BM-7)

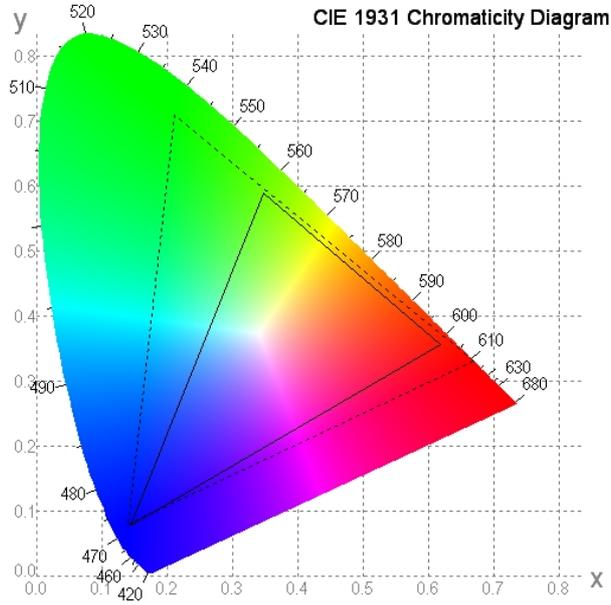

7.6. Definition of Surface Luminance, Uniformity and Transmittance

Using the transmissive mode measurement approach, measure the white screen luminance of the display panel and backlight.

7.6.1. Surface Luminance: $L_v = \text{average} (L_{P1}:L_{P9})$

7.6.2. Uniformity = $\text{Minimal} (L_{P1}:L_{P9}) / \text{Maximal} (L_{P1}:L_{P9}) * 100\%$

7.6.3. Transmittance = $L_v \text{ on LCD} / L_v \text{ on Backlight} * 100\%$

Note : Measuring machine: BM-7

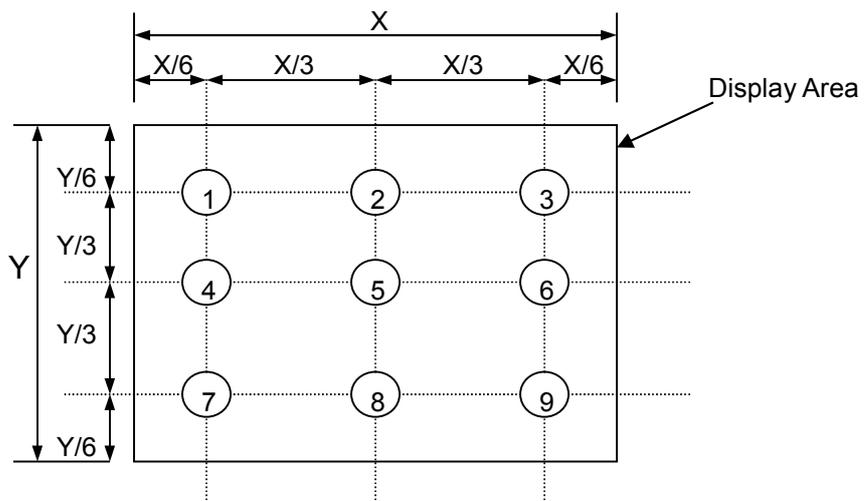

8. Block Diagram and Power Supply

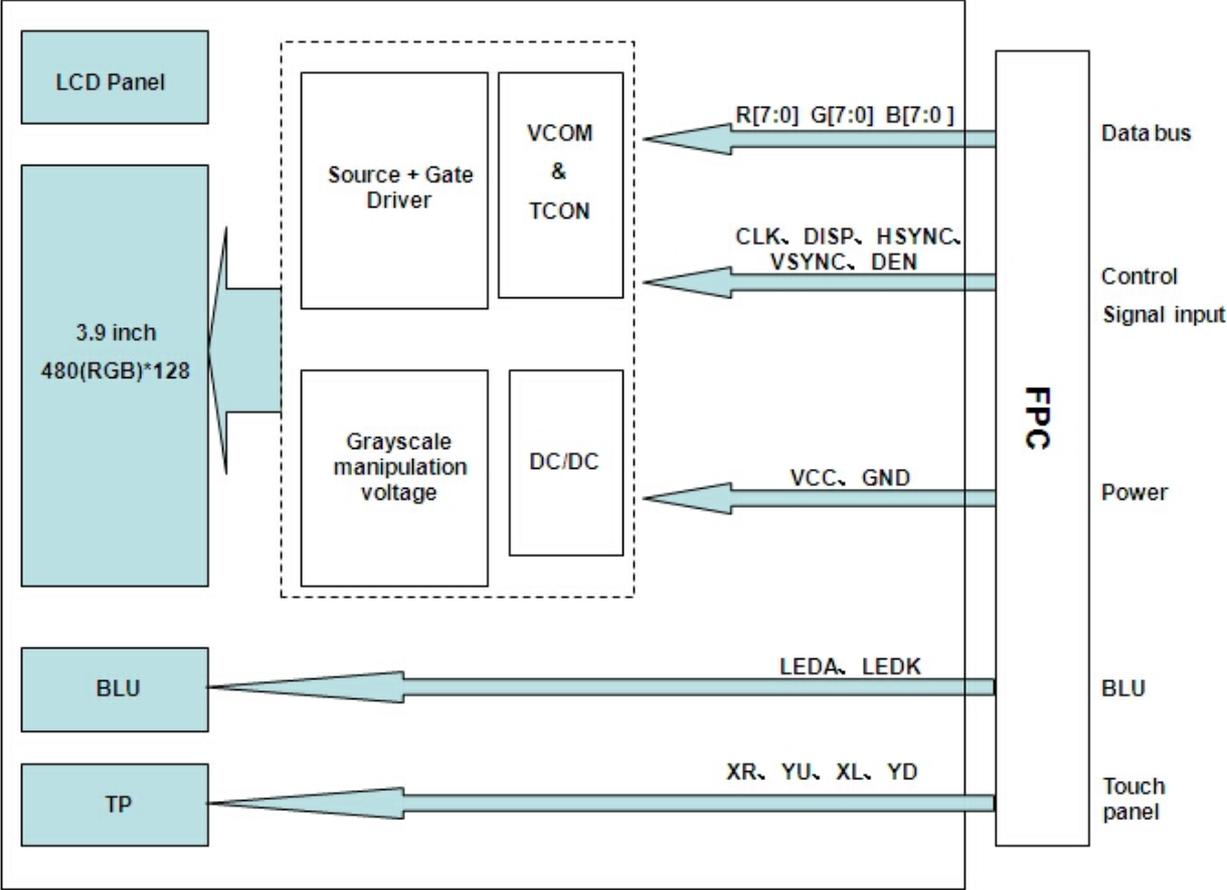

9. Interface Pins Definition

No.	Symbol	Function	Remark
1	LEDK	Backlight Cathode	
2	LEDA	Backlight Anode	
3	GND	Ground	
4	VCC	Power source	
5	R0	Red data signal	
6	R1	Red data signal	
7	R2	Red data signal	
8	R3	Red data signal	
9	R4	Red data signal	
10	R5	Red data signal	
11	R6	Red data signal	
12	R7	Red data signal	
13	G0	Green data signal	
14	G1	Green data signal	
15	G2	Green data signal	
16	G3	Green data signal	
17	G4	Green data signal	
18	G5	Green data signal	
19	G6	Green data signal	
20	G7	Green data signal	
21	B0	Blue data signal	
22	B1	Blue data signal	
23	B2	Blue data signal	
24	B3	Blue data signal	
25	B4	Blue data signal	
26	B5	Blue data signal	
27	B6	Blue data signal	
28	B7	Blue data signal	
29	GND	Ground	
30	CLK	Clock signal to sample each data	
31	DISP	DISP="H" Display on; DISP="L" Display off	
32	HSYNC	Horizontal synchronizing signal	
33	VSYNC	Vertical synchronizing signal	
34	DEN	Input data enable control. (In SYNC mode this pin should not be used.)	
35	NC	No connection	
36	GND	Ground	
37	XR	Touch panel terminal.	
38	YD	Touch panel terminal.	
39	XL	Touch panel terminal.	
40	YU	Touch panel terminal.	

10. AC Characteristics

VDDIO=1.8V, VDD = 3.3V, AVDD = 6V, AGND = 0V, T_A = -20°C to 80°C

Item	Symbol	Min.	Typ.	Max.	Unit	Conditions
CLK pulse duty	T _{cw}	40	50	60	%	
Hsync width	T _{hw}	1.0	-	-	DCLK	
Hsync period	T _h	55	60	65	us	
Vsync setup time	T _{vst}	12	-	-	ns	
Vsync hold time	T _{vhd}	12	-	-	ns	
Hsync setup time	T _{hst}	12	-	-	ns	
Hsync hold time	T _{hhd}	12	-	-	ns	
Data set-up time	T _{dsu}	12	-	-	ns	
Data hold time	T _{dhd}	12	-	-	ns	
DE set-up time	T _{desu}	12	-	-	ns	
DE hold time	T _{dehd}	12	-	-	ns	
SD output stable time	T _{st}	-	10	12	us	
GD output rise and fall time	T _{gst}	-	500	1000	ns	

Clock and Data Input Timing Diagram

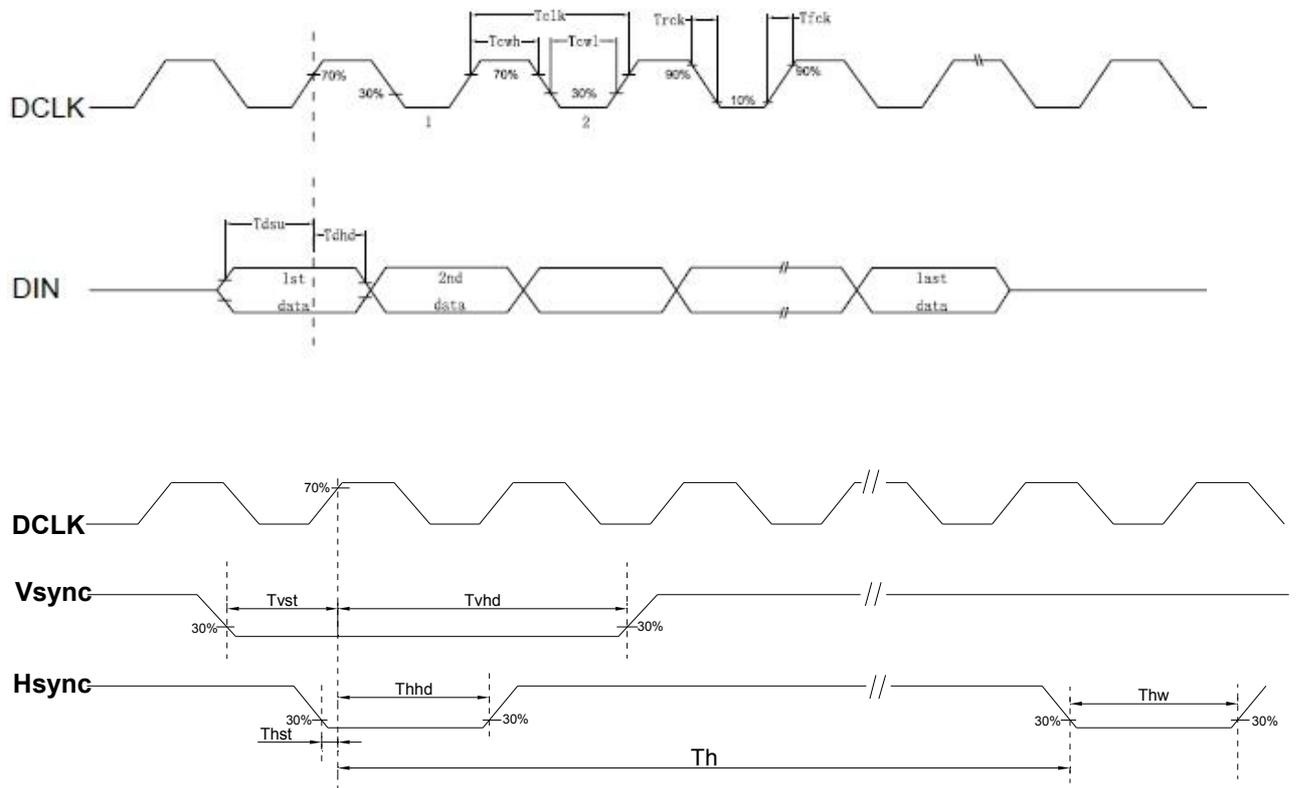

11. INPUT DATA FORMAT

11.1 Parallel RGB Input Timing Table

Item	System	Min.	Typ.	Max.	Unit	
DCLK Frequency	Fclk	-	10.7	-	MHz	
Hsync	Period Time	Th	524	-	DCLK	
	Display Period	Thdisp	480	-	DCLK	
	Back Porch	Thbp	43	-	DCLK	By H_BLANKING setting
	Front Porch	Thfp	1	-	DCLK	
	Pulse Width	Thw	2	-	DCLK	
Vsync	Period Time	Tv	288	-	H	
	Display Period	Tvdisp	272	-	H	
	Back Porch	Tvbp	12	-	H	By V_BLANKING setting
	Front Porch	Tvfp	4	-	H	
	Pulse Width	Tvw	2	-	H	

Note: The 1-144 gate lines must be sent black data.

11.2 SYNC Mode Timing Diagram

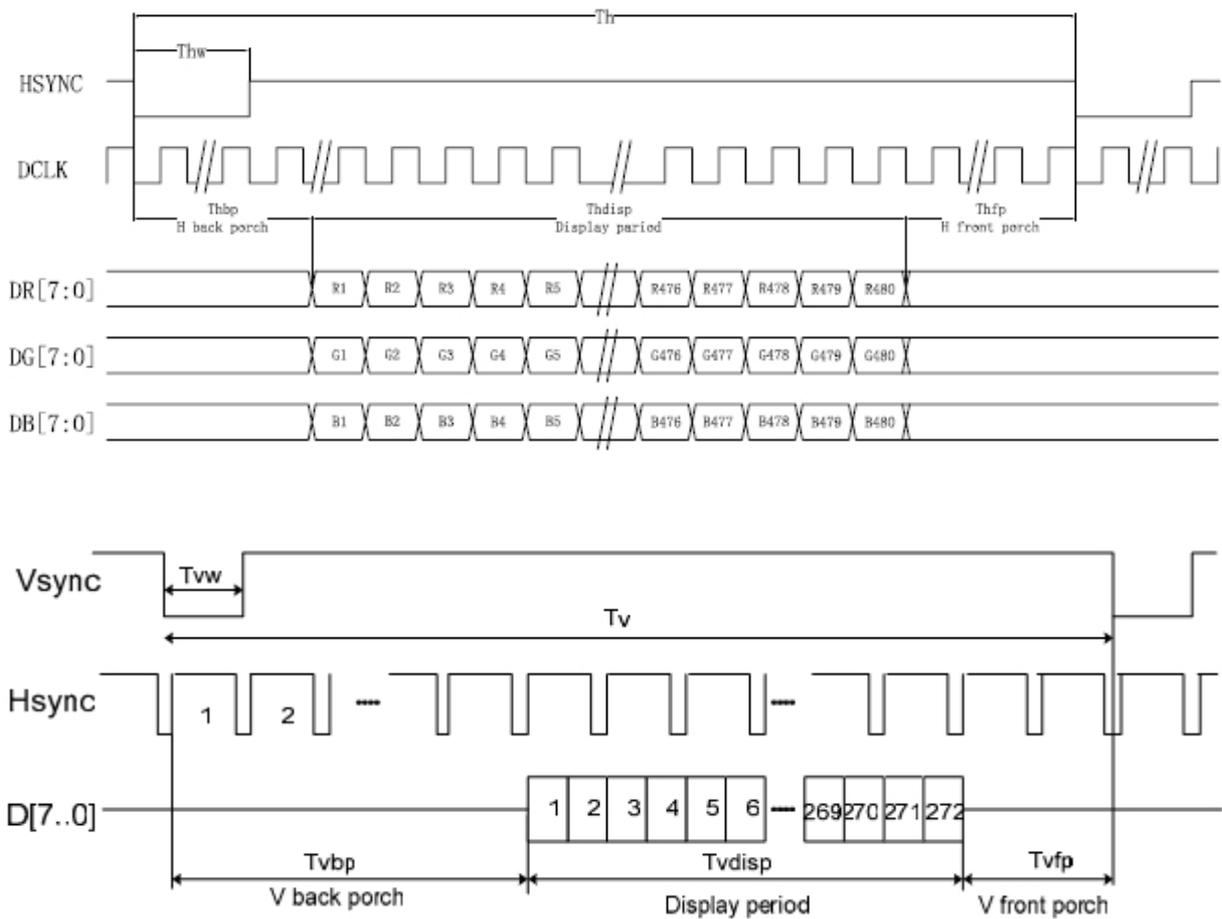

12. Quality Assurance

12.1 Purpose

This standard for Quality Assurance assures the quality of LCD module products supplied to customer.

12.2 Standard for Quality Test

12.2.1 Sampling Plan:

GB2828.1-2012

Single sampling, general inspection level II

12.2.2 Sampling Criteria:

Visual inspection: AQL 1.5%

Electrical functional: AQL 0.65%.

12.2.3 Reliability Test:

Detailed requirement refer to Reliability Test Specification.

12.3 Nonconforming Analysis & Disposition

12.3.1 Nonconforming analysis:

12.3.1.1 Customer should provide overall information of non-conforming sample for their complaints.

12.3.1.2 After receipt of detailed information from customer, the analysis of nonconforming parts usually should be finished in one week.

12.3.1.3 If cannot finish the analysis on time, customer will be notified with the progress status.

12.3.2 Disposition of nonconforming:

12.3.2.1 Non-conforming product over PPM level will be replaced.

12.3.2.2 The cause of non-conformance will be analyzed. Corrective action will be discussed and implemented.

12.4 Agreement Items

Shall negotiate with customer if the following situation occurs:

12.4.1 There is any discrepancy in standard of quality assurance.

12.4.2 Additional requirement to be added in product specification.

12.4.3 Any other special problem.

12.5 Standard of the Product Visual Inspection

12.5.1 Appearance inspection:

12.5.1.1 The inspection must be under illumination about 1000 – 1500 lx, and the distance of view must be at 30cm ± 2cm.

12.5.1.2 The viewing angle should be 45° from the vertical line without reflection light or follows customer's viewing angle specifications.

12.5.1.3 Definition of area: A Zone: Active Area, B Zone: Viewing Area,

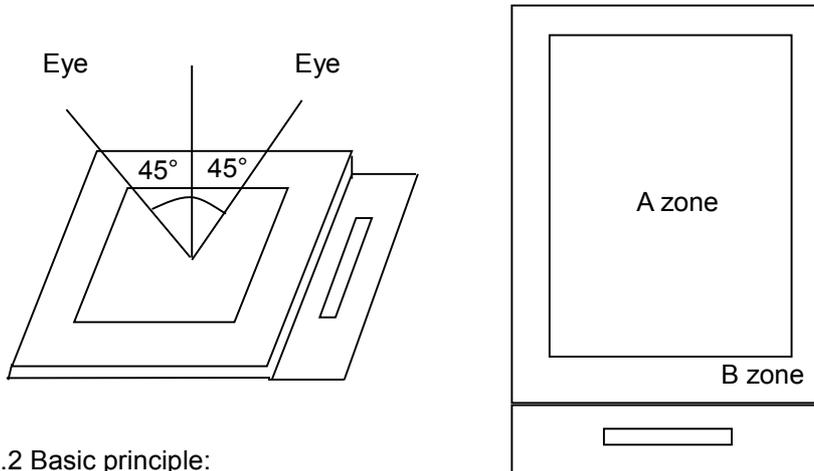

12.5.2 Basic principle:

12.5.2.1 A set of sample to indicate the limit of acceptable quality level must be discussed by both us and customer when there is any dispute happened.

12.5.2.2 New item must be added on time when it is necessary.

12.6 Inspection Specification

No.	Item	Criteria (Unit: mm)																			
01	Black / White spot Foreign material (Round type) Pinholes Stain Particles inside cell. (Minor defect)	$\phi = (a + b) / 2$ Distance between 2 defects should more than 3mm apart.	<table border="1"> <thead> <tr> <th>Size</th> <th>Area</th> <th>Acc. Qty</th> </tr> </thead> <tbody> <tr> <td>$\phi \leq 0.10$</td> <td></td> <td>Ignore</td> </tr> <tr> <td>$0.10 < \phi \leq 0.15$</td> <td></td> <td>2</td> </tr> <tr> <td>$0.15 < \phi \leq 0.25$</td> <td></td> <td>1</td> </tr> <tr> <td>$0.25 < \phi$</td> <td></td> <td>0</td> </tr> <tr> <td>Total</td> <td></td> <td>2 no include $\phi \leq 0.10$</td> </tr> </tbody> </table>	Size	Area	Acc. Qty	$\phi \leq 0.10$		Ignore	$0.10 < \phi \leq 0.15$		2	$0.15 < \phi \leq 0.25$		1	$0.25 < \phi$		0	Total		2 no include $\phi \leq 0.10$
			Size	Area	Acc. Qty																
$\phi \leq 0.10$		Ignore																			
$0.10 < \phi \leq 0.15$		2																			
$0.15 < \phi \leq 0.25$		1																			
$0.25 < \phi$		0																			
Total		2 no include $\phi \leq 0.10$																			

02	Electrical Defect (Minor defect)	<table border="1"> <tr> <th></th> <th>Display Area</th> <th>Total</th> <th rowspan="4">Note1</th> </tr> <tr> <td>Bright dot</td> <td>0</td> <td>0</td> </tr> <tr> <td>Dark dot</td> <td>$N \leq 2$</td> <td>$N \leq 2$</td> </tr> <tr> <td>Total dot</td> <td>$N \leq 2$</td> <td>$N \leq 2$</td> </tr> <tr> <td>Mura</td> <td colspan="2">Not visible through 5% ND filter.</td> <td>Note 2</td> </tr> </table>		Display Area	Total	Note1	Bright dot	0	0	Dark dot	$N \leq 2$	$N \leq 2$	Total dot	$N \leq 2$	$N \leq 2$	Mura	Not visible through 5% ND filter.		Note 2
			Display Area	Total	Note1														
		Bright dot	0	0															
		Dark dot	$N \leq 2$	$N \leq 2$															
		Total dot	$N \leq 2$	$N \leq 2$															
Mura	Not visible through 5% ND filter.		Note 2																
Remark:																			
1. Bright dot caused by scratch and foreign object accords to item 1.																			
03	Inactive Area (Minor defect)	Line Criteria: $L \leq 1\text{mm}$, $W \leq 0.1\text{mm}$, Dot Criteria: Please refer to Note 1,2&3																	
		Note1: Definition of Area																	
		Note 2:																	
		<table border="1"> <thead> <tr> <th>Size</th> <th>Inactive dot</th> <th>Center</th> <th>Outer</th> <th>Total</th> <th>Remark</th> </tr> </thead> <tbody> <tr> <td>All</td> <td>$\Phi < 0.2\text{mm}$</td> <td colspan="4">Is not counted</td> </tr> <tr> <td><6"</td> <td>$0.2 \leq \Phi \leq 0.3\text{mm}$ $L \leq 1\text{mm}, W \leq 0.1\text{mm}$</td> <td>$N \leq 1$</td> <td>$N \leq 2$</td> <td>$N \leq 3$</td> <td></td> </tr> </tbody> </table>	Size	Inactive dot	Center	Outer	Total	Remark	All	$\Phi < 0.2\text{mm}$	Is not counted				<6"	$0.2 \leq \Phi \leq 0.3\text{mm}$ $L \leq 1\text{mm}, W \leq 0.1\text{mm}$	$N \leq 1$	$N \leq 2$	$N \leq 3$
Size	Inactive dot	Center	Outer	Total	Remark														
All	$\Phi < 0.2\text{mm}$	Is not counted																	
<6"	$0.2 \leq \Phi \leq 0.3\text{mm}$ $L \leq 1\text{mm}, W \leq 0.1\text{mm}$	$N \leq 1$	$N \leq 2$	$N \leq 3$															
Remark:																			
Effective area is from the POL cutting side to 0.5mm of inside. This is no count area. Other part is effective area. In no count area, any defect can ignore. In effective area, have to judge from above-mentioned specification.																			

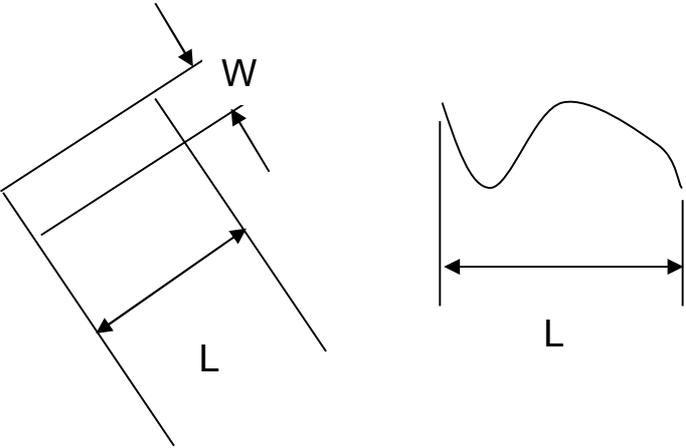
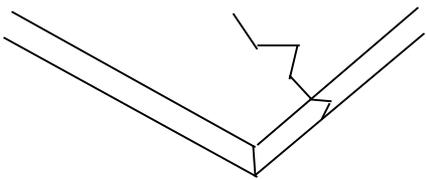
<p>04</p>	<p>Black and White line Scratch Foreign material (Line type) (Minor defect)</p>	 <table border="1" data-bbox="609 846 1236 1153"> <thead> <tr> <th>Length</th> <th>Width</th> <th>Acc. Qty</th> </tr> </thead> <tbody> <tr> <td>/</td> <td>$W \leq 0.03$</td> <td>Ignore</td> </tr> <tr> <td>$L \leq 2.5$</td> <td>$0.03 < W \leq 0.05$</td> <td>3</td> </tr> <tr> <td>$L \leq 2.5$</td> <td>$0.05 < W \leq 0.10$</td> <td>2</td> </tr> <tr> <td>/</td> <td>$0.1 < W$</td> <td>0</td> </tr> <tr> <td colspan="2">Total</td> <td>3</td> </tr> </tbody> </table> <p>Distance between 2 defects should more than 3mm apart. Scratches not viewable through the back of the display are acceptable.</p>	Length	Width	Acc. Qty	/	$W \leq 0.03$	Ignore	$L \leq 2.5$	$0.03 < W \leq 0.05$	3	$L \leq 2.5$	$0.05 < W \leq 0.10$	2	/	$0.1 < W$	0	Total		3
Length	Width	Acc. Qty																		
/	$W \leq 0.03$	Ignore																		
$L \leq 2.5$	$0.03 < W \leq 0.05$	3																		
$L \leq 2.5$	$0.05 < W \leq 0.10$	2																		
/	$0.1 < W$	0																		
Total		3																		
<p>05</p>	<p>Glass Crack (Minor defect)</p>	 <p>Crack is potential to enlarge, any type is not allowed.</p>																		

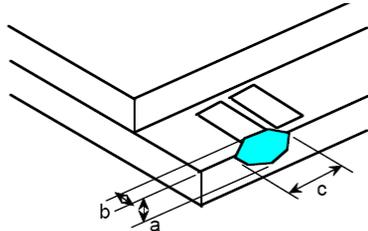
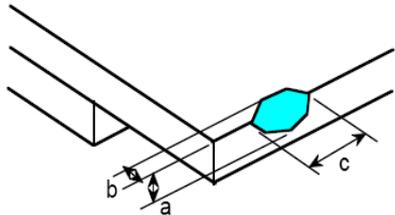
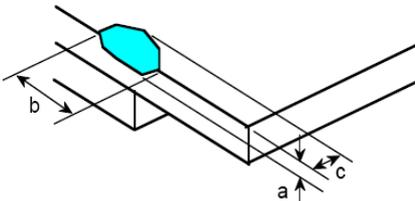
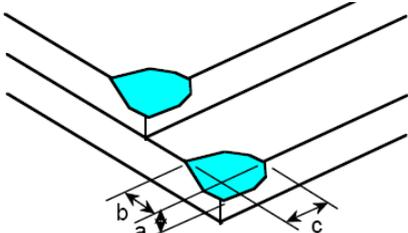
<p>06</p>	<p>Glass Chipping Pad Area: (Minor defect)</p> 	<table border="1"> <thead> <tr> <th>Length and Width</th> <th>Acc. Qty</th> </tr> </thead> <tbody> <tr> <td>$c > 3.0, b < 1.0$</td> <td>1</td> </tr> <tr> <td>$c < 3.0, b < 1.0$</td> <td>3</td> </tr> <tr> <td colspan="2">$a < \text{Glass Thickness}$</td> </tr> </tbody> </table>	Length and Width	Acc. Qty	$c > 3.0, b < 1.0$	1	$c < 3.0, b < 1.0$	3	$a < \text{Glass Thickness}$			
Length and Width	Acc. Qty											
$c > 3.0, b < 1.0$	1											
$c < 3.0, b < 1.0$	3											
$a < \text{Glass Thickness}$												
<p>07</p>	<p>Glass Chipping Rear of Pad Area: (Minor defect)</p> 	<table border="1"> <thead> <tr> <th>Length and Width</th> <th>Acc. Qty</th> </tr> </thead> <tbody> <tr> <td>$c > 3.0, b < 1.0$</td> <td>1</td> </tr> <tr> <td>$c < 3.0, b < 1.0$</td> <td>2</td> </tr> <tr> <td>$c < 3.0, b < 0.5$</td> <td>4</td> </tr> <tr> <td colspan="2">$a < \text{Glass Thickness}$</td> </tr> </tbody> </table>	Length and Width	Acc. Qty	$c > 3.0, b < 1.0$	1	$c < 3.0, b < 1.0$	2	$c < 3.0, b < 0.5$	4	$a < \text{Glass Thickness}$	
Length and Width	Acc. Qty											
$c > 3.0, b < 1.0$	1											
$c < 3.0, b < 1.0$	2											
$c < 3.0, b < 0.5$	4											
$a < \text{Glass Thickness}$												
<p>08</p>	<p>Glass Chipping Except Pad Area: (Minor defect)</p> 	<table border="1"> <thead> <tr> <th>Length and Width</th> <th>Acc. Qty</th> </tr> </thead> <tbody> <tr> <td>$c > 3.0, b < 1.0$</td> <td>1</td> </tr> <tr> <td>$c < 3.0, b < 1.0$</td> <td>2</td> </tr> <tr> <td>$c < 3.0, b < 0.5$</td> <td>4</td> </tr> <tr> <td colspan="2">$a < \text{Glass Thickness}$</td> </tr> </tbody> </table>	Length and Width	Acc. Qty	$c > 3.0, b < 1.0$	1	$c < 3.0, b < 1.0$	2	$c < 3.0, b < 0.5$	4	$a < \text{Glass Thickness}$	
Length and Width	Acc. Qty											
$c > 3.0, b < 1.0$	1											
$c < 3.0, b < 1.0$	2											
$c < 3.0, b < 0.5$	4											
$a < \text{Glass Thickness}$												
<p>09</p>	<p>Glass Corner Chipping: (Minor defect)</p> 	<table border="1"> <thead> <tr> <th>Length and Width</th> <th>Acc. Qty</th> </tr> </thead> <tbody> <tr> <td>$c < 3.0, b < 3.0$</td> <td>Ignore</td> </tr> <tr> <td colspan="2">$a < \text{Glass Thickness}$</td> </tr> </tbody> </table>	Length and Width	Acc. Qty	$c < 3.0, b < 3.0$	Ignore	$a < \text{Glass Thickness}$					
Length and Width	Acc. Qty											
$c < 3.0, b < 3.0$	Ignore											
$a < \text{Glass Thickness}$												

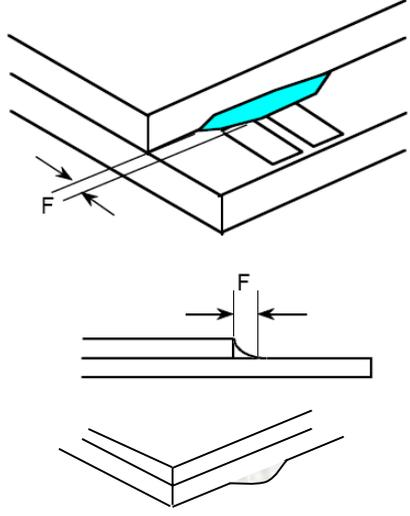
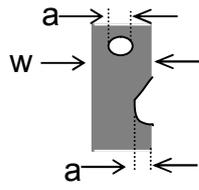
<p>10</p>	<p>Glass Burr: (Minor defect)</p> 	<table border="1" data-bbox="885 264 1356 353"> <thead> <tr> <th>Length</th> <th>Acc. Qty</th> </tr> </thead> <tbody> <tr> <td>$F < 1.0$</td> <td>Ignore</td> </tr> </tbody> </table> <p>Glass burr don't affect assemble and module dimension.</p>	Length	Acc. Qty	$F < 1.0$	Ignore						
Length	Acc. Qty											
$F < 1.0$	Ignore											
<p>11</p>	<p>FPC Defect: (Minor defect)</p> 	<p>11.1 Dent, pinhole width $a < w/3$. (w: circuitry width.)</p> <p>11.2 Open circuit is unacceptable.</p> <p>11.3 No oxidation, contamination and distortion.</p>										
<p>12</p>	<p>Bubble on Polarizer (Minor defect)</p>	<table border="1" data-bbox="758 1303 1228 1518"> <thead> <tr> <th>Diameter</th> <th>Acc. Qty</th> </tr> </thead> <tbody> <tr> <td>$\varphi \leq 0.20$</td> <td>Ignore</td> </tr> <tr> <td>$0.20 < \varphi \leq 0.30$</td> <td>4</td> </tr> <tr> <td>$0.30 < \varphi \leq 0.50$</td> <td>1</td> </tr> <tr> <td>$0.50 < \varphi$</td> <td>None</td> </tr> </tbody> </table>	Diameter	Acc. Qty	$\varphi \leq 0.20$	Ignore	$0.20 < \varphi \leq 0.30$	4	$0.30 < \varphi \leq 0.50$	1	$0.50 < \varphi$	None
Diameter	Acc. Qty											
$\varphi \leq 0.20$	Ignore											
$0.20 < \varphi \leq 0.30$	4											
$0.30 < \varphi \leq 0.50$	1											
$0.50 < \varphi$	None											
<p>13</p>	<p>Dent on Polarizer (Minor defect)</p>	<table border="1" data-bbox="758 1579 1228 1794"> <thead> <tr> <th>Diameter</th> <th>Acc. Qty</th> </tr> </thead> <tbody> <tr> <td>$\varphi \leq 0.20$</td> <td>Ignore</td> </tr> <tr> <td>$0.20 < \varphi \leq 0.30$</td> <td>4</td> </tr> <tr> <td>$0.30 < \varphi \leq 0.50$</td> <td>1</td> </tr> <tr> <td>$0.50 < \varphi$</td> <td>None</td> </tr> </tbody> </table>	Diameter	Acc. Qty	$\varphi \leq 0.20$	Ignore	$0.20 < \varphi \leq 0.30$	4	$0.30 < \varphi \leq 0.50$	1	$0.50 < \varphi$	None
Diameter	Acc. Qty											
$\varphi \leq 0.20$	Ignore											
$0.20 < \varphi \leq 0.30$	4											
$0.30 < \varphi \leq 0.50$	1											
$0.50 < \varphi$	None											
<p>14</p>	<p>Bezel</p>	<p>14.1 No rust, distortion on the Bezel.</p> <p>14.2 No visible fingerprints, stains or other contamination.</p>										

15	Touch Panel	D: Diameter W: width L: length 15.1 Spot: $D < 0.25$ is acceptable $0.25 \leq D \leq 0.4$ 2dots are acceptable and the distance between defects should more than 10 mm. $D > 0.4$ is unacceptable 15.2 Dent: $D > 0.40$ is unacceptable 15.3 Scratch: $W \leq 0.03$, $L \leq 10$ is acceptable, $0.03 < W \leq 0.10$, $L \leq 10$ is acceptable Distance between 2 defects should more than 10 mm. $W > 0.10$ is unacceptable.
16	PCB	16.1 No distortion or contamination on PCB terminals. 16.2 All components on PCB must same as documented on the BOM/component layout. 16.3 Follow IPC-A-600F.
17	Soldering	Follow IPC-A-610C standard
18	Electrical Defect (Major defect)	The below defects must be rejected. 18.1 Missing vertical / horizontal segment, 18.2 Abnormal Display. 18.3 No function or no display. 18.4 Current exceeds product specifications. 18.5 LCD viewing angle defect. 18.6 No Backlight. 18.7 Dark Backlight. 18.8 Touch Panel no function.

Remark: LCD Panel Broken shall be rejected. Defect out of LCD viewing area is acceptable.

12.7 Classification of Defects

12.7.1 Visual defects (Except no / wrong label) are treated as minor defect and electrical defect is major.

12.7.2 Two minor defects are equal to one major in lot sampling inspection.

12.8 Identification/marketing criteria

Any unit with illegible / wrong /double or no marking/ label shall be rejected.

12.9 Packing

12.9.1 There should be no damage of the outside carton box, each packaging box should have one identical label.

12.9.2 Modules inside package box should have compliant mark.

12.9.3 All direct package materials shall offer ESD protection

Note1: Bright dot is defined as the defective area of the dot is larger than 50% of one sub-pixel area.

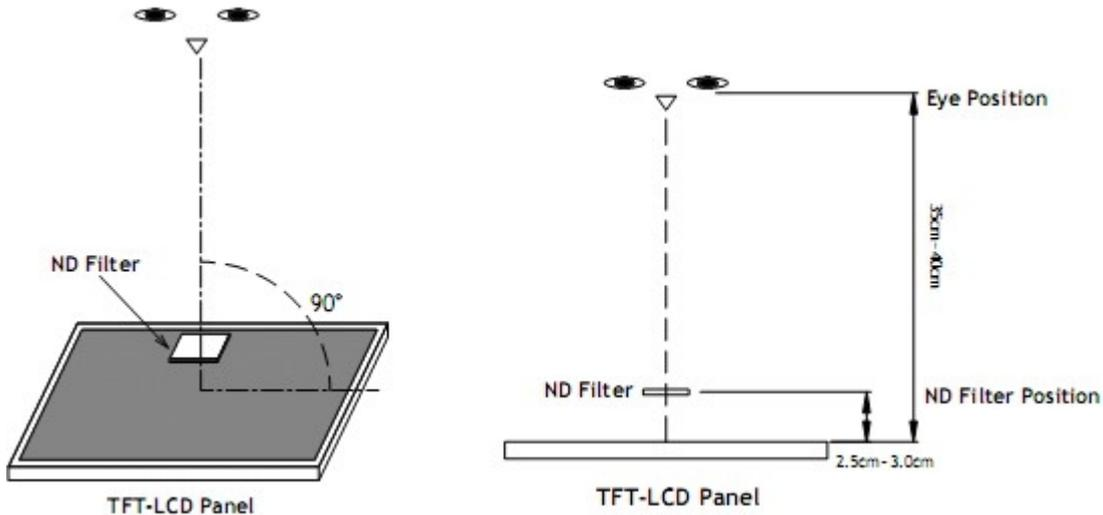

Bright dot: The bright dot size defect at black display pattern. It can be recognized by 2% transparency of filter when the distance between eyes and panel is 350mm ± 50mm.

Dark dot: Cyan, Magenta or Yellow dot size defect at white display pattern. It can be recognized by 5% transparency of filter when the distance between eyes and panel is 350mm ± 50mm.

Note2: Mura on display which appears darker / brighter against background brightness on parts of display area

13. Reliability Specification

No	Item	Condition	Quantity	Criteria
1	High Temperature Operating	+70°C, 96Hrs	2	GB/T2423.2-2008
2	Low Temperature Operating	-20°C, 96Hrs	2	GB/T2423.1-2008
3	High Humidity	+50°C, 90%RH, 96Hrs	2	GB/T2423.3-2006
4	High Temperature Storage	+80°C, 96Hrs	2	GB/T2423.2-2008
5	Low Temperature Storage	-30°C, 96Hrs	2	GB/T2423.1-2008
6	Thermal Cycling Test	-20°C, 60min~70°C, 60min, 20 cycles.	2	GB/T2423.22-2012
7	Packing vibration	Frequency range:10Hz~50Hz Acceleration of gravity:5G X, Y, Z 30 min for each direction.	2	GB/T5170.14-2009
8	Electrical Static Discharge	Air: ±8kV 150pF/330 Ω 5 times Contact: ±4kV 150pF/330 Ω 5 times	2	GB/T17626.2-2006
9	Drop Test (Packaged)	Height:80 cm,1 corner, 3 edges, 6 surfaces.	2	GB/T2423.8-1995

Note1. No defection cosmetic and operational function allowable.

Note2. Total current Consumption should be below double of initial value

14. Precautions and Warranty

14.1 Safety

14.1.1 The liquid crystal in the LCD is poisonous. Do not put it in your mouth. If the liquid crystal touches your skin or clothes, wash it off immediately using soap and water.

14.1.2 Since the liquid crystal cells are made of glass, do not apply strong impact on them. Handle with care.

14.2 Handling

14.2.1 Reverse and use within ratings in order to keep performance and prevent damage.

14.2.2 Do not wipe the polarizer with dry cloth, as it might cause scratch. If the surface of the LCD needs to be cleaned, wipe it swiftly with cotton or other soft cloth soaked with petroleum IPA, do not use other chemicals.

14.3 Storage

14.3.1 Do not store the LCD module beyond the specified temperature ranges.

14.4 Metal Pin (Apply to Products with Metal Pins)

14.4.1 Pins of LCD and Backlight

14.4.1.1 Solder tip can touch and press on the tip of Pin LEAD during the soldering

14.4.1.2 Recommended Soldering Conditions

Solder Type: Sn96.3~94-Ag3.3~4.3-Cu0.4~1.1

Maximum Solder Temperature: 370℃

Maximum Solder Time: 3s at the maximum temperature

Recommended Soldering Temp: 350±20℃

Typical Soldering Time: ≤3s

14.4.1.3 Solder Wetting

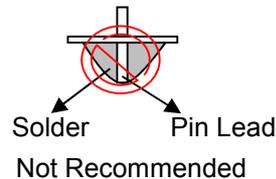
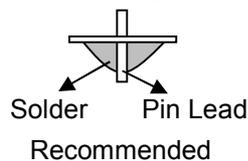

14.4.2 Pins of EL

14.4.2.1 Solder tip can touch and press on the tip of EL leads during soldering.

14.4.2.2 No Solder Paste on the soldering pad on the motherboard is recommended.

14.4.2.3 Recommended Soldering Conditions

Solder type: Nippon Alimit Leadfree SR-34, size 0.5mm

Recommended Solder Temperature: 270~290℃

Typical Soldering Time: ≤2s

Minimum solder distance from EL lamp (body):2.0mm

14.4.2.4 No horizontal press on the EL leads during soldering.

14.4.2.5 180° bend EL leads three times is not allowed.

14.4.2.6 Solder Wetting

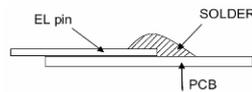

Recommended

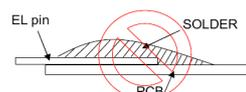

Not Recommended

14.4.2.7 The type of the solder iron:

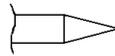

Recommended

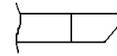

Not Recommended

14.4.2.8 Solder Pad

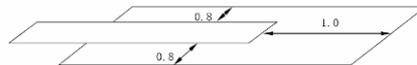

14.5 Operation

14.5.1 Do not drive LCD with DC voltage

14.5.2 Response time will increase below lower temperature

14.5.3 Display may change color with different temperature

14.5.4 Mechanical disturbance during operation, such as pressing on the display area, may cause the segments to appear “fractured”.

14.6 Static Electricity

14.6.1 CMOS LSIs are equipped in this unit, so care must be taken to avoid the electro-static charge, by ground human body, etc.

14.6.2 The normal static prevention measures should be observed for work clothes and benches.

14.6.3 The module should be kept into anti-static bags or other containers resistant to static for storage.

14.7 Limited Warranty

14.7.1 Our warranty liability is limited to repair and/or replacement. We will not be responsible for any consequential loss.

14.7.2 If possible, we suggest customer to use up all modules in six months. If the module storage time over twelve months, we suggest that recheck it before the module be used.

14.7.3 After the product shipped, any product quality issues must be feedback within three months, otherwise, we will not be responsible for the subsequent or consequential events.

15. Outline Drawing

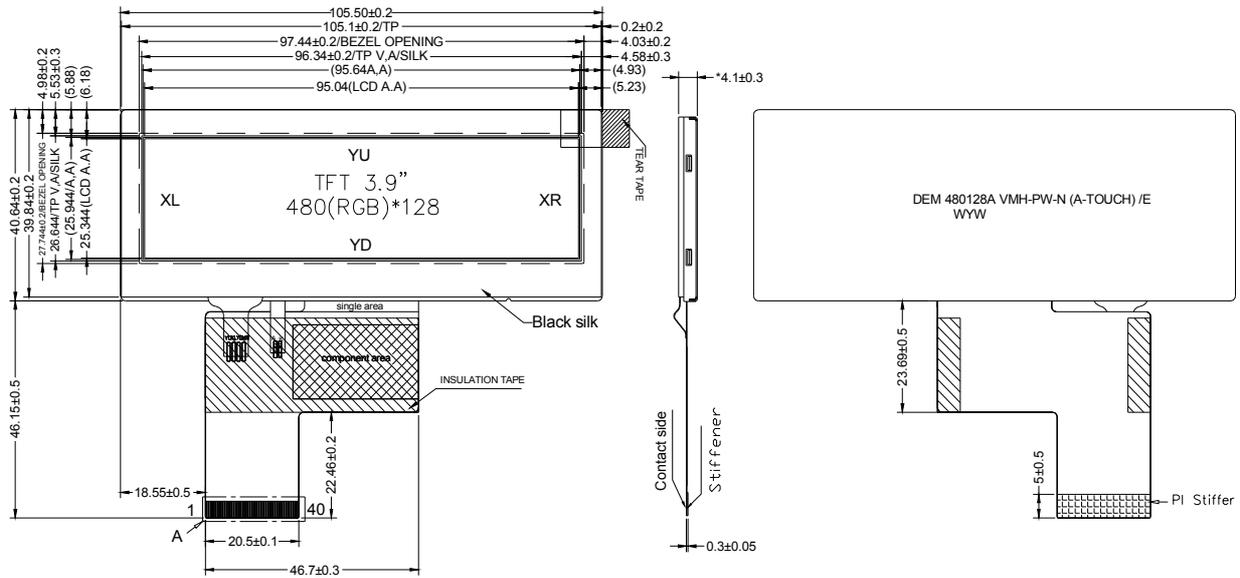

NOTES:

1. Display Size: 3.9" TFT
2. Viewing Direction: 12 O'CLOCK
3. Grey Scale Inversion Direction: 6 O'CLOCK
3. Display Mode: Transmissive / Normal White
4. Operation Temperature: -20°C ~ +70°C
5. Storage Temperature: -30°C ~ +80°C
6. Driver IC: OTA5180A
7. Power Supply Voltage: 3.3V
8. Backlight: White(12xLED) / 19.2V/40mA
9. LED Lifetime: 30000 hrs

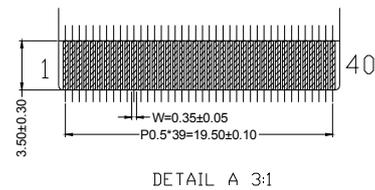
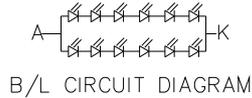

* Unspecification tolerance are ±0.2mm

Pin assignment	
1	LE DK
2	LE DA
3	GND
4	VCC
5	R0
6	R1
7	R2
8	R3
9	R4
10	R5
11	R6
12	R7
13	G0
14	G1
15	G2
16	G3
17	G4
18	G5
19	G6
20	G7
21	B0
22	B1
23	B2
24	B3
25	B4
26	B5
27	B6
28	B7
29	GND
30	CLK
31	DISP
32	Hsync
33	Vsync
34	DEN
35	NC
36	GND
37	XR
38	YD
39	XL
40	YU