

DISPLAY Elektronik GmbH

DATA SHEET

LCD MODULE

DEM 160160C FGH-PW

Product Specification

Version: 3

27.11.2017

GENERAL SPECIFICATION
MODULE NO. :
DEM 160160C FGH-PW

CUSTOMER P/N

VERSION NO.	CHANGE DESCRIPTION	DATE
0	Original Version	22.05.2017
1	Correct Module and Backlight Drawing	15.11.2017
2	Update Module / PCB / Backlight Drawing.	23.11.2017
3	Correct Backlight Drawing	27.11.2017

PREPARED BY: HZH

DATE: 27.11.2017

APPROVED BY: MH

DATE: 27.11.2017

CONTENTS

1. FUNCTIONS &FEATURES 4

2. MODULE ARTWORK..... 4

3. EXTERNAL DIMENSIONS 5

4. BLOCK DIAGRAM..... 6

5. PIN ASSIGNMENT..... 6

6. POWER SUPPLY..... 7

7. PCB DESCRIPTION 7

8. ABSOLUTE MAXIMUM RATINGS 9

9. BACKLIGHT COMPONENT ELECTRICAL/OPTICAL SPECIFICATIONS 9

10. LUMINANCE OF MODULE IN FRONT OF THE GLASS..... 10

11. DC CHARACTERISTICS..... 11

12. AC CHARACTERISTICS..... 12

13. OPTICAL CHARACTERISTICS 15

14. QUALITY DESCRIPTION..... 17

15. MODULE ACCEPT QUALITY LEVEL (AQL)..... 18

16. RELIABILITY TEST..... 18

17. LCD MODULES HANDLING PRECAUTIONS 19

18. OTHERS..... 19

1. FUNCTIONS & FEATURES

MODULE NAME	LCD TYPE
DEM 160160C FGH-PW	FSTN Transflective Positive Mode

- Viewing Direction : 6 O'clock
- Driving Scheme : 1/160 Duty, 1/13 Bias,
- Supply voltage : 3.3 Volt (typ.)
- V_{LCD} : 20.0 Volt (typ.)
- Backlight color : LED, Lightguide, White
- Interface : 4-Bit-Parallel MCU
- Drive IC : UCi7701c-TAB (Ultrachip)

2. MODULE ARTWORK

- Module size : 76.50 x 71.50 x 10.40 (without FFC)
- LCD Active Area : 55.985 x 55.985 mm
- LCD Viewing Area : 61.50 x 61.50 mm
- Dot Pitch : : 0.35 x 0.35 mm
- Dot Size : 0.335 x 0.335 mm
- Dot Gap : 0.015 mm

3. EXTERNAL DIMENSIONS

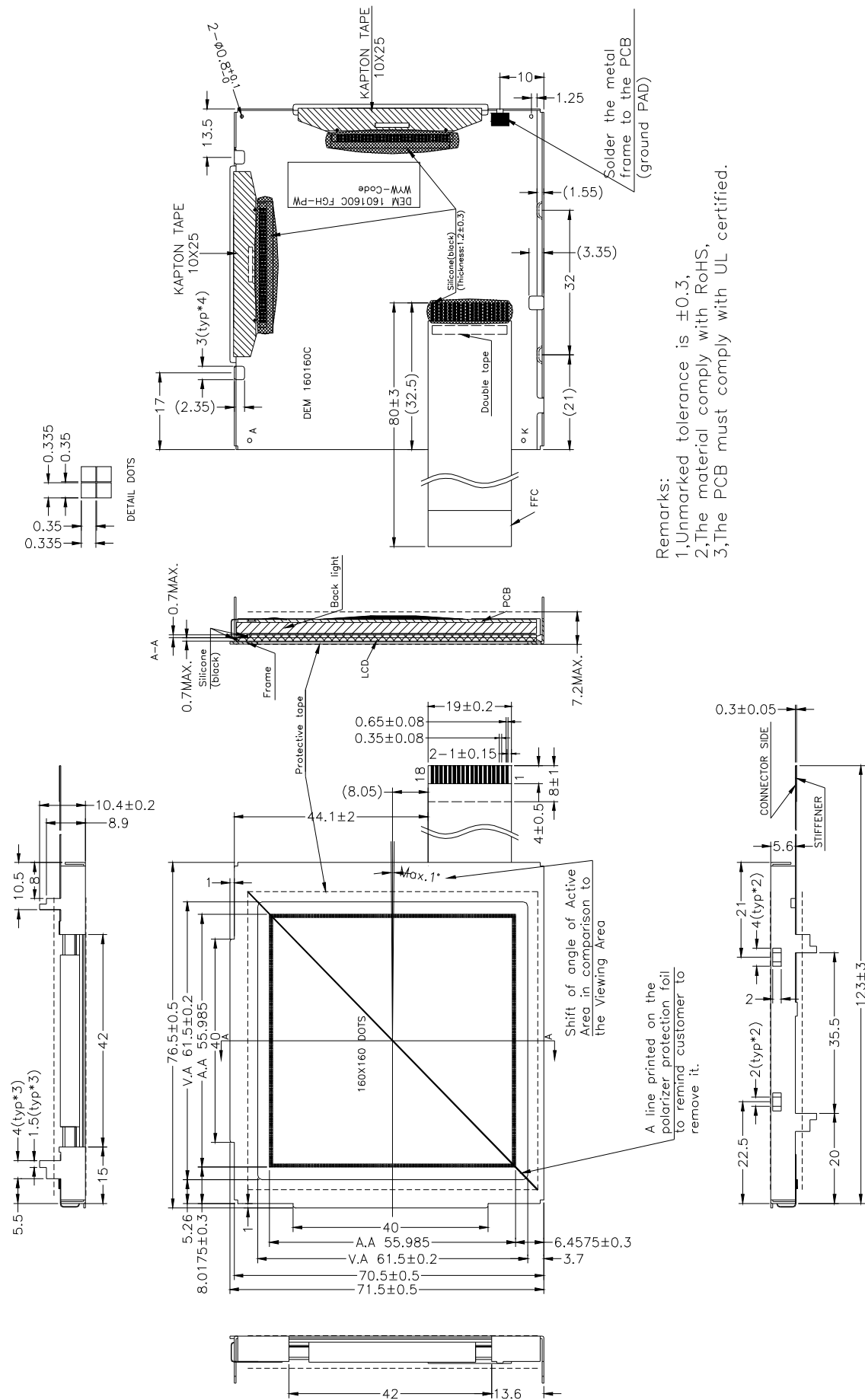

4. BLOCK DIAGRAM

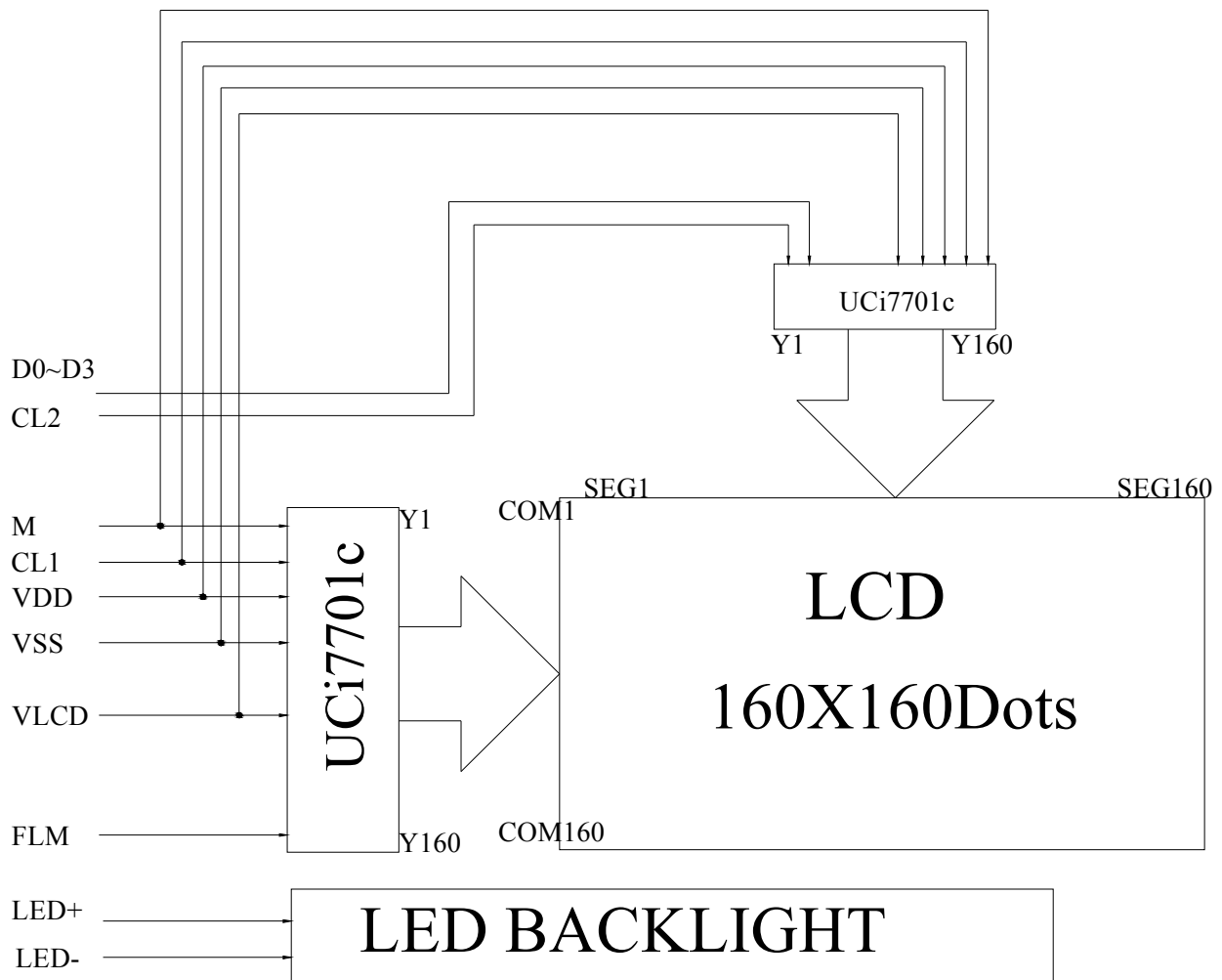

5. PIN ASSIGNMENT

PIN NUMBER	SYMBOL	FUNCTION
1	VSS	Ground
2	FLM	First line mark for common scan
3	CL1	H→L Data latch pulse
4	CL2	Clock pulse for segment shift register
5	M	H/L Frame reverse signal
6	VDD	Power supply for logic (+3.3V)
7	GND	Connect for GND
8	VEE	Power supply for LCD
9~12	D3~D0	Input data signal
13	GND	Connect for GND
14	GND	
15	GND	
16	GND	
17	LED(+)	Please refer to Item 7-1
18	LED(-)	Please refer to Item 7-1

6. POWER SUPPLY

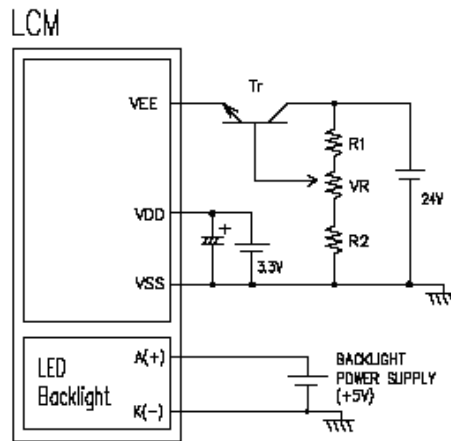

(NOTE) $R1+R2+VR \approx 20K\Omega$

7. PCB DESCRIPTION

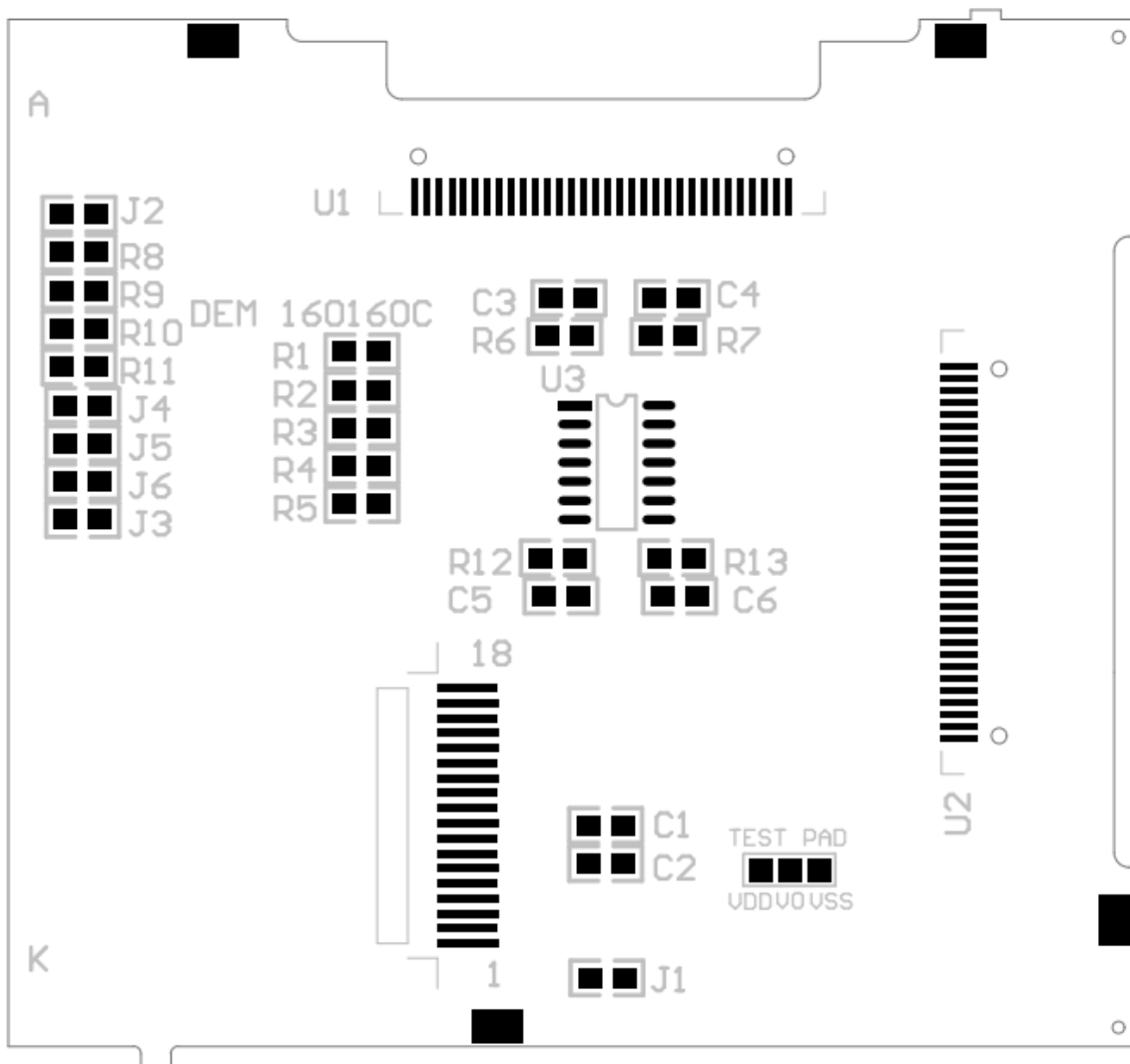

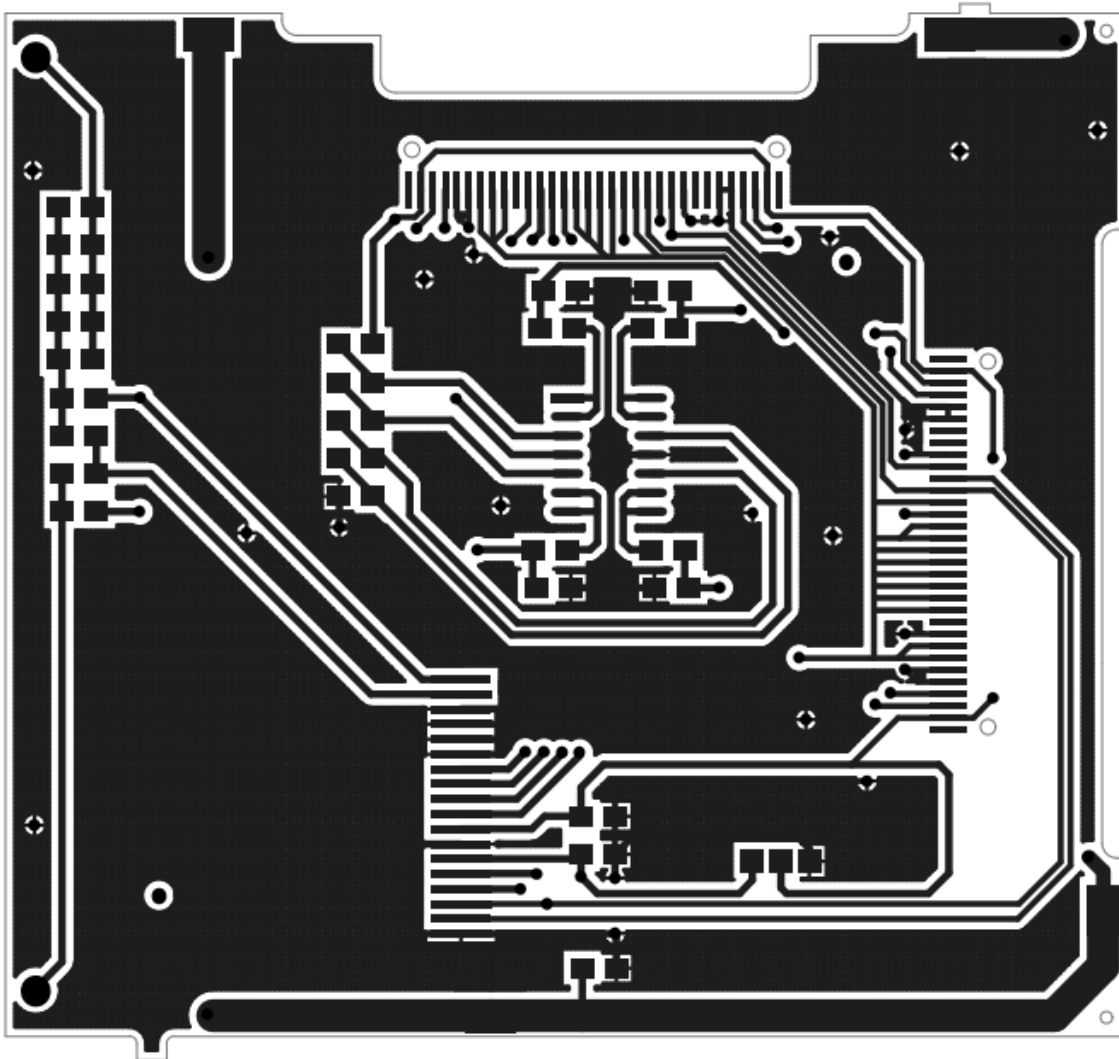

7-1.The polarity of the pin 17 and the pin 18:

J3,J5	J6, J4	LED Polarity	
		17 Pin	18 Pin
Each closed	Each open	Anode	Cathode
Each open	Each closed	Cathode	Anode

Note: In application module, J3=J5 =closed, J4=J6=open.

7-2. The J1 is metal-bezel GND to module GND.

Note: In application module, J1=closed.

7-3 .The LED resistors are not in use if J2 is closed.

Note: In application module, J2=open

7-4.The R8 and the R9, R10, R11 are the LED resistor.

Note: In application module, R8=R9=100 Ohm, R10=R11=Not used.

8. ABSOLUTE MAXIMUM RATINGS

Parameter	Symbol	Min.	Max.	Unit	Note
Supply Voltage Logic	V _{DD}	-0.3	7.0	V	
Input Voltage	V _I	-0.3	V _{DD} +0.3	V	
Supply Voltage Vo	V _{led}	-0.3	45	V	
Operating Temperature	---	-20	+70	°C	
Storage Temperature	--	-40	+80	°C	
Operating Humidity	----	50%	75%	RH	
Storage Humidity	----	50%	75%	RH	

9. BACKLIGHT COMPONENT ELECTRICAL/OPTICAL SPECIFICATIONS

Electrical–Optical Characteristics (T_a=25°C)

Item	Symbol	MIN.	TYP.	MAX.	Unit	Condition
Forward Voltage	V _f		3.1	3.5	V	I _f = 45 mA
Colour Coordinate (Tolerances is ±0.01)	x	0.24		0.32	---	
	y	0.24		0.32	---	
Uniformity (MIN/MAX X 100%)	Avg	70			%	
Luminance	L _v	490	700		cd/m ²	
Reverse Current (Per LED)	I _r			50	UA	V _r = 3.0 V

● Operating Temperature: -30~+80°C ● Storage Temperature: -40~+80°C

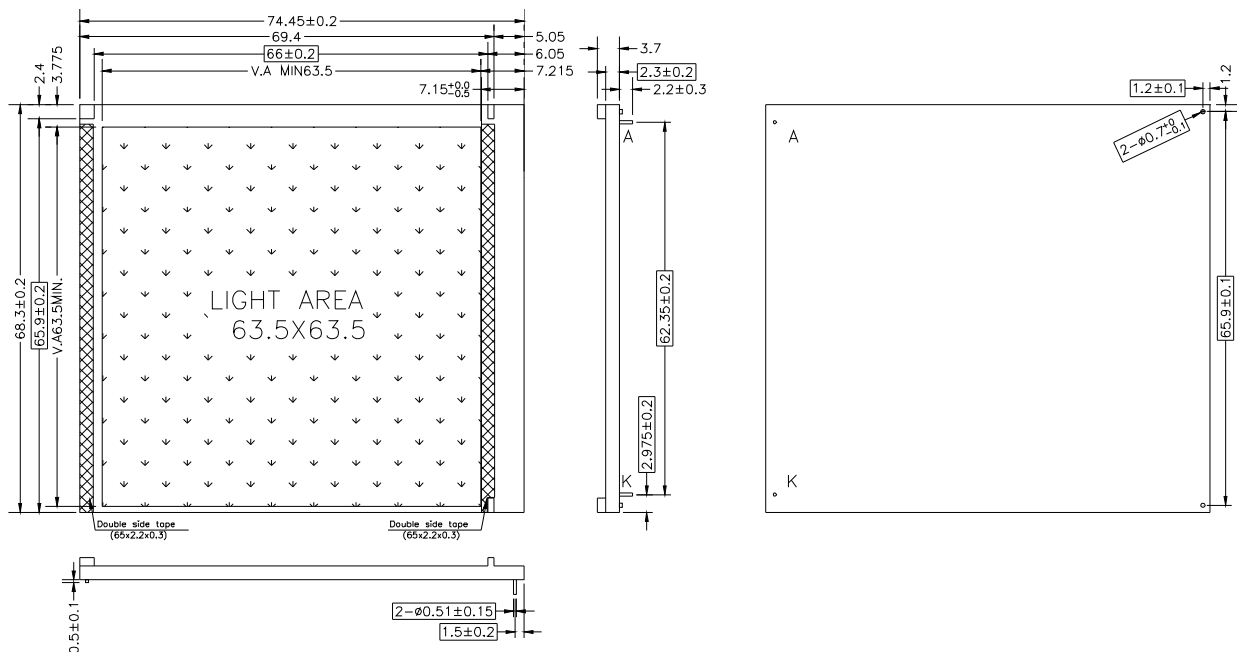

Remarks:

1. Unmarked tolerance is ±0.3
 2. The material comply with RoHS
- 3I_f=15X6=90mA, Lifetime=50000 hours (reduce by 50% brightness):
 1I_f=10X6=60mA, Lifetime=80000 hours:
 1I_f=8X6=48mA, Lifetime=100000 hours

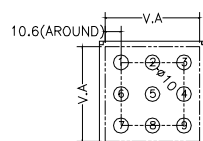
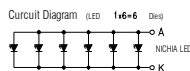

10. LUMINANCE OF MODULE IN FRONT OF THE GLASS

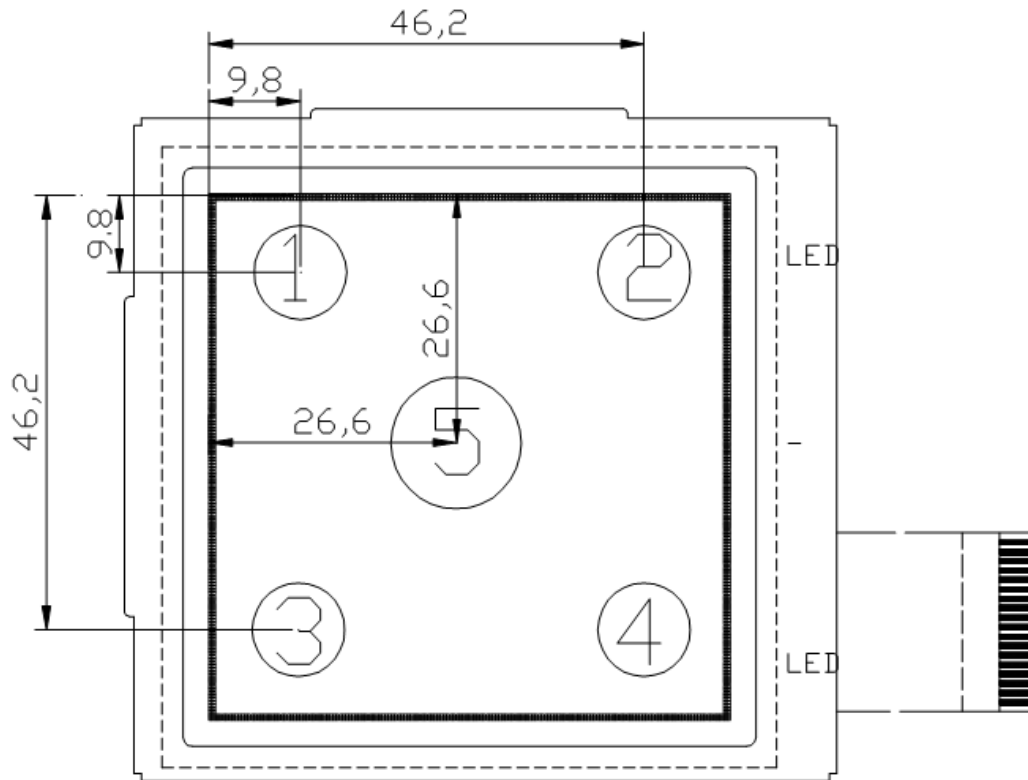

FSTN Transflective Positive Mode

Backlight current	Measuring points					Average	Unit	Remark
	1	2	3	4	5			
45mA	62.9	70.2	73.9	71	78.1	71.22	Cd/m ²	LCD OFF
30mA	40.6	45.6	44.9	45.9	50.4	45.48		
24mA	33.2	36.7	34.8	38	41.2	36.78		
45mA	17.3	17.3	15.6	19.8	19.1	17.82	Cd/m ²	LCD ON
30mA	10.4	10.7	10.1	11.5	11.1	10.76		
24mA	8.37	8.78	7.55	9.53	9	8.646		

11. DC CHARACTERISTICS(V_{SS}= 0V, Ta = 25°C)

Parameter	Symbol	Min.	Typ	Max	Unit
Supply Voltage Logic	V _{DD}	2.5	3.3	5.5	V
Consumed Current	I _{DD}	0.2	0.30	0.45	mA

LCD driving voltage on different Temperature (VLCD)

V_{LCD} (Min) means that contrast is little visible from 6:00, $\alpha=10^\circ$ V_{LCD} (Typ) means that contrast is best from 6:00, $\alpha=10^\circ$ V_{LCD} (Max) means that contrast is still visible, before starting to see all dots from 6:00, $\alpha=10^\circ$

Temperature	Min.	Typ	Max	Unit	Remark
-20°C	18.8	20.4	24	V	Tolerance=±0.2
+25°C	18.0	20.0	23.4	V	
+70°C	16.5	18.2	20.0	V	

12. AC CHARACTERISTICS

12.1 UCi7701c Segment Mode AC Characteristics

(V_{SS}= 0V, Ta=-20~+70°C)

Parameter	Symbol	Min.	Typ.	Max.	Unit	Condition
Shift clock period	tWCK	125	-		ns	tr, tf ≤ 11ns, Note 1
Shift clock "H" pulse width	tWCKH	51	-		ns	
Shift clock "L" pulse width	tWCKL	51	-		ns	
Data setup time	tDS	30	-		ns	
Data hold time	tDH	40	-		ns	
Latch pulse "H" pulse width	tWLPH	51	-		ns	
Shift clock rise to Latch pulse rise time	tLD	0	-		ns	
Shift clock fall to Latch pulse fall time	tSL	51	-		ns	
Latch pulse rise to Shift clock rise time	tLS	51	-		ns	
Latch pulse fall to Shift clock fall time	tLH	51	-		ns	
Input signal rise time	tr		-	50	ns	Note 2
Input signal fall time	tf		-	50	ns	Note 2
Enable setup time	tS	36	-		ns	
DISPOFF Removal time	tSD	100	-		ns	
DISPOFF enable pulse width	tWDL	1.2	-		μs	
Output delay time (1)	tD		-	78	ns	CL = 15pF
Output delay time (2)	tpd1, tpd2		-	1.2	μs	CL = 15pF
Output delay time (3)	tpd3		-	1.2	μs	CL = 15pF

Note:

1. Take the cascade connection into consideration.
2. (tCK - tWCKH - tWCKL)/2 is the maximum in the case of high speed operation.

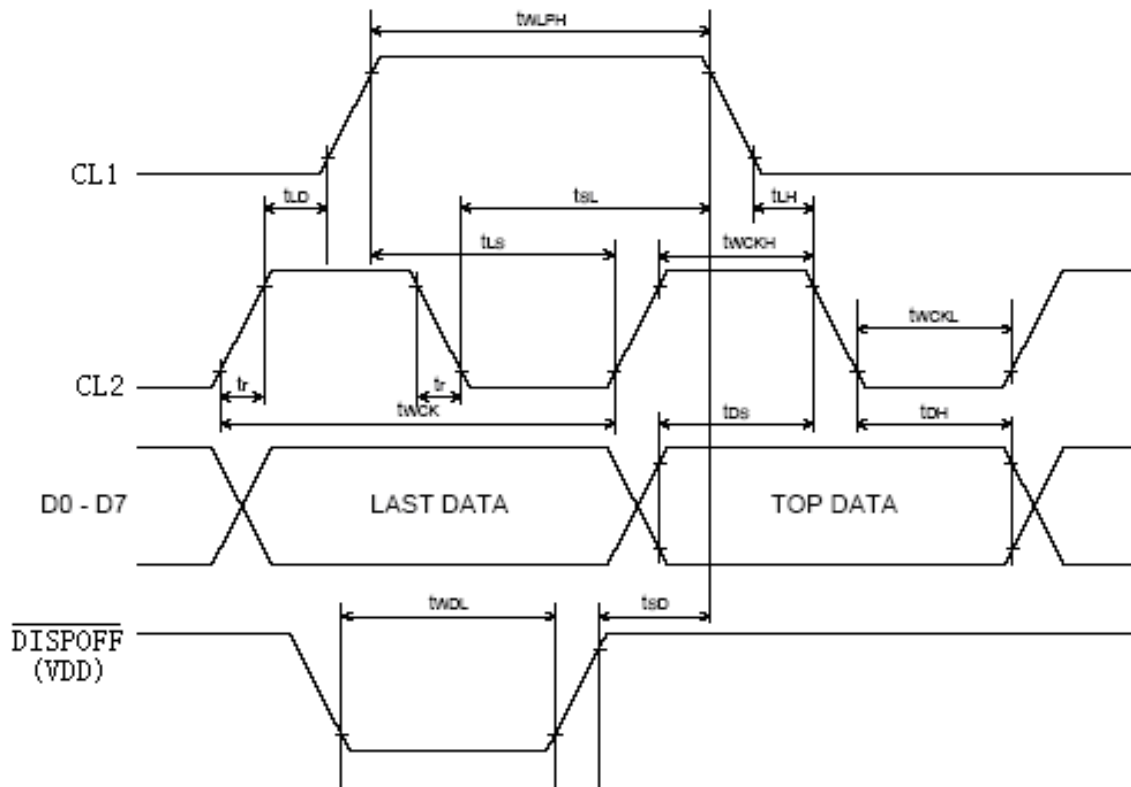

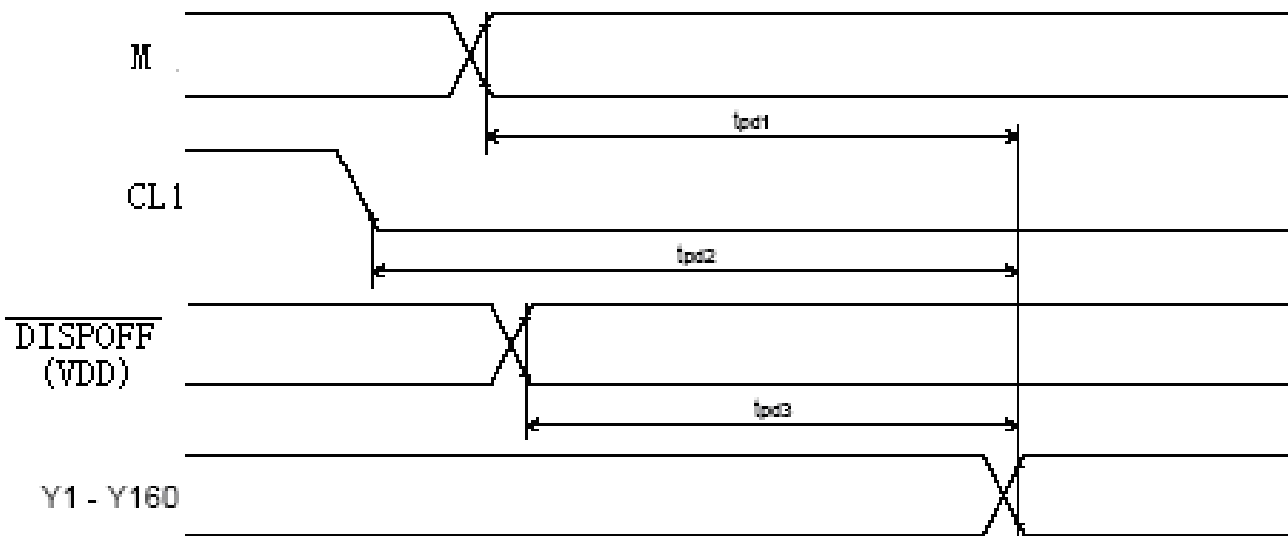
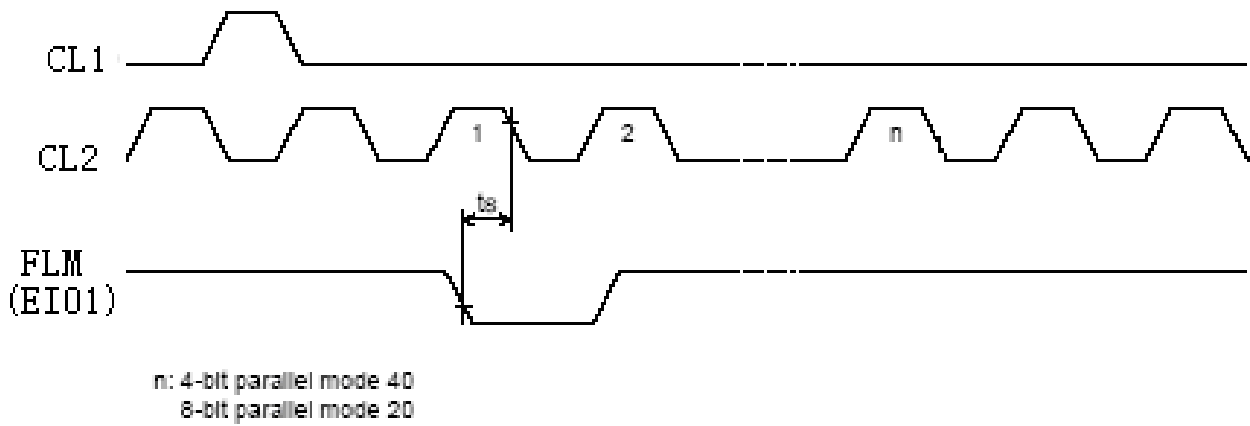

12.2 UCi7701c Common Mode AC Characteristics

(V_{SS}= 0V, Ta=25°C)

Parameter	Symbol	Min.	Typ.	Max.	Unit	Condition
Shift clock period	tWLP	250	-	-	ns	tr, tf ≤ 20ns
Shift clock "H" pulse width	tWLPH	15	-	-	ns	VDD = +5.0V ± 10%
		30	-	-	ns	VDD = +2.5 - +4.5V
Data setup time	tSU	30	-	-	ns	
Data hole time	tH	50	-	-	ns	
Input signal rise time	tr		-	50	ns	
Input signal fall time	tf		-	50	ns	
DISPOFF Removal time	tSD	100	-	-	ns	
DISPOFF enable pulse width	tWDL	1.2	-	-	μs	
Output delay time (1)	tDL	-	-	200	ns	CL = 15pF
Output delay time (2)	tpd1, tpd2	-	-	1.2	μs	CL = 15pF
Output delay time (3)	tpd3	-	-	1.2	μs	CL = 15pF

Timing Characteristics of Common Mode

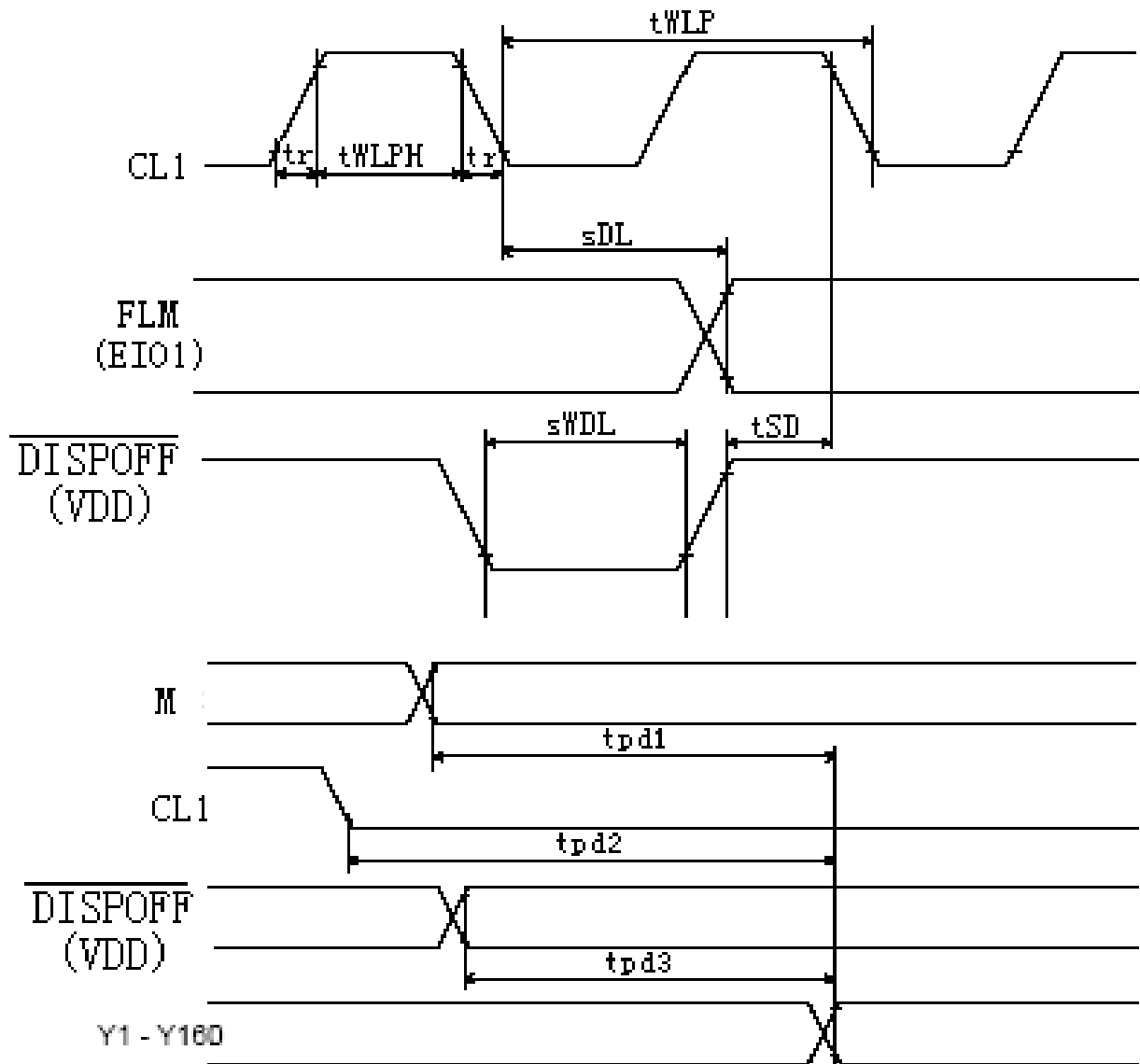

13. OPTICAL CHARACTERISTICS

13.1 Overall optical performance

Positive display (FSTN):

(Ta=25°C)

ITEM	SYMBOL	CONDITIONS	TYP.	UNIT	REMARKS
Viewing angles for Contrast Ratio CR > 3	α	$\Phi = 0^\circ$ $\Phi = 90^\circ$ $\Phi = 180^\circ$ $\Phi = 270^\circ$	50 40 50 45	°	Transflective operation

Definition of viewing angles Φ , α and contrast ratio OR

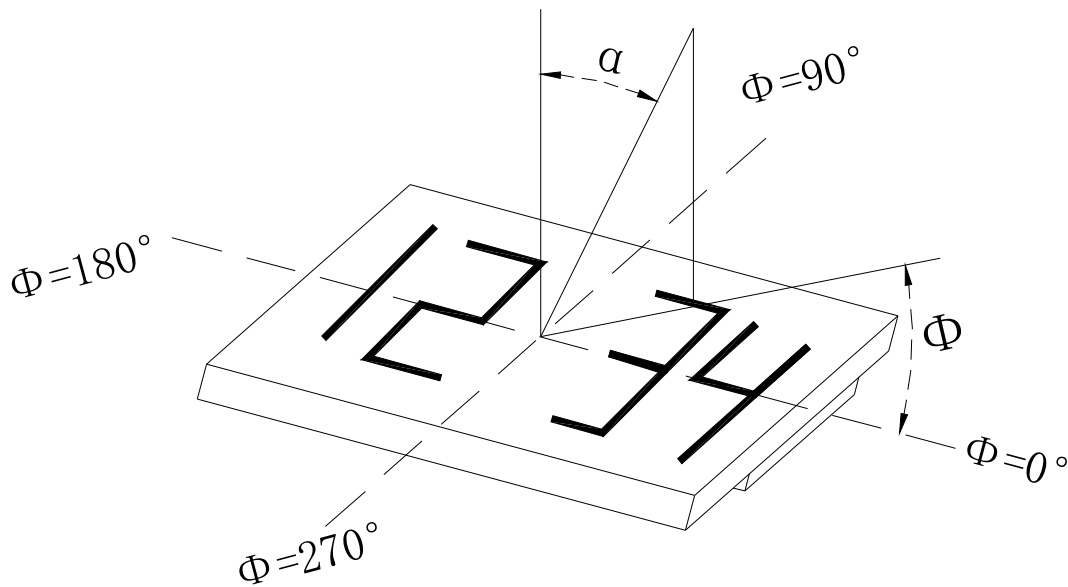

$$\text{Contrast ratio OR} = \frac{\text{Brightness of OFF-segments}}{\text{Brightness of ON-segments}}$$

13.2 Response times at different temperatures

Response times t_{on} and t_{off} are measured using simulated MUX at $f=f_{FRAME}$. V_{op} (+25°C) will be identical to V_{op} (+25°C) as specified for the viewing angles.

Item	Symbol	Conditions	Min.	Typ.	Max.	Unit	Remarks
Response Times	t_{on}	-20°C	-	1680.962	-	ms	$\alpha = 0^\circ, \Phi = 0^\circ$
	t_{off}	-20°C	-	1388.747	-	ms	
	t_{on}	0°C	-	254.418	-	ms	
	t_{off}	0°C	-	486.562	-	ms	
	t_{on}	25°C	-	40.617	-	ms	
	t_{off}	25°C	-	121.495	-	ms	

Remark: value will be measured after sampling.

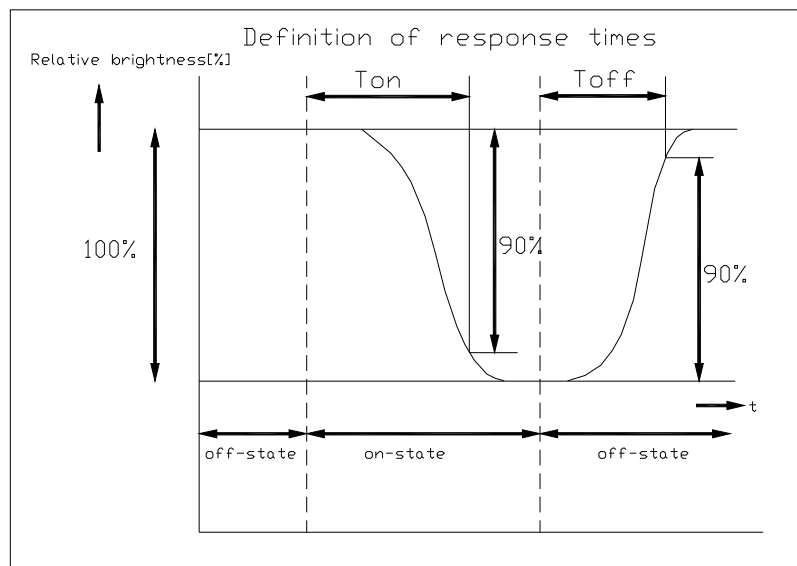

14. QUALITY DESCRIPTION

DEFECT SPECIFICATION:

Related documents, covering general aspects of evaluation of defects:

UZM-Q0/H004-01: Cell defect specification.

UZM-Q0/H004-02: Module defect specification.

Specific type-related items are covered in this sheet.

All defects, specified herein, are in category 2 (acc. to UZM-Q0/H004-01).

- a: Table for Cosmetic defects
(Note: nc = not counted).
Sizes and number of defects
(Max. Qty)

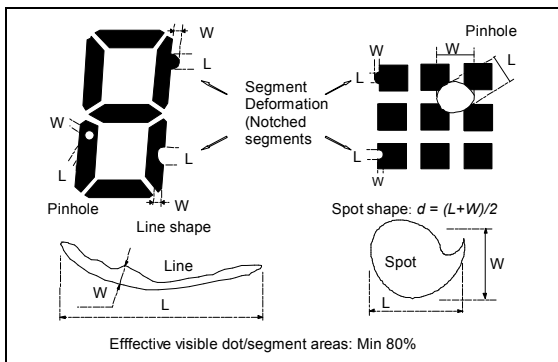

Examples/

Defect Type	Max. defect size [μm] d or L W	Max. Quantity
Black or White Spots	$d \leq 150$	nc
	$150 < d \leq 300$	5
Black or White Lines	--	nc
	$W \leq 10$	
	$L \leq 5000$ $W \leq 30$	3
	$L \leq 2000$ $W \leq 50$	2
Pinhole	$d \leq 150$	nc
	$150 < d \leq 300$	1/segment
(Total defects)		(5)
Segment Deformation	$W \leq 100$	nc
Bubble (e.g. under pola)	$d \leq 150$	nc
	$200 < d \leq 400$	3
	$400 < d \leq 600$	1

Shapes

b: Glass defects

b1: Glass defects at contact ledge

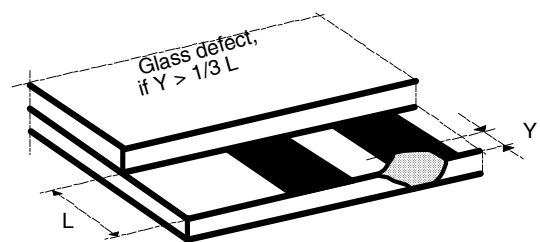

b2: Glass chipping in other areas shall not be in conflict with the product's function.

15. MODULE ACCEPT QUALITY LEVEL (AQL)

15.1 AQL Standard Value: Fatal Defect =0.1, Major Defect=0.65; Minor Defect =2.5.

15.2 Curtailed Inspection Scheme

Type	Batch Qty	AQL value	pass	Reject
module product	350PCS < 1000PCS	0.1	0	1
		0.65	2	3
		2.5	7	8
	200PCS < 350PCS	0.1	0	1
		0.65	1	2
		2.5	5	6
	<200PCS	0.1	0	1
		0.65	0	1
		2.5	4	5
Module sample	<200PCS	/	/	The sample will be reject when the fateful defect>2pcs or main defect>5pcs.
	>200PCS			

- Notes:**
- 1). Batch QTY is the production amount that Production department ship to QA department.
 - 2). All of product will be inspected if the batch QTY less than inspected QTY.
 - 3). Each batch fixed to be 500pcs.

16. RELIABILITY TEST

Operating Lifetime: Longer than 50000 hours (at room temperature without direct irradiation of sunlight)
Reliability characteristics shall meet following requirements.

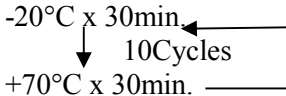
TEMPERATURE TESTS	NORMAL GRADE
High Temperature Storage	+80°C x 120hrs (Without Polarizer)
Low Temperature Storage	-40°C x 120hrs
High Temperature Operation	+70°C x 120hrs
Low Temperature Operation	-20°C x 120hrs
High Temperature, High Humidity	+60°C x 90%RH x 120hrs (Without Polarizer)
Thermal Shock	-20°C x 30min.  +70°C x 30min.

17. LCD MODULES HANDLING PRECAUTIONS

- Please remove the protection foil of polarizer before using.
- The display panel is made of glass. Do not subject it to a mechanical shock by dropping it from a high place, etc.
- If the display panel is damaged and the liquid crystal substance inside it leaks out, do not get any in your mouth. If the substance come into contact with your skin or clothes promptly wash it off using soap and water.
- Do not apply excessive force to the display surface or the adjoining areas since this may cause the color tone to vary.
- The polarizer covering the display surface of the LCD module is soft and easily scratched. Handle this polarize carefully.
- To prevent destruction of the elements by static electricity, be careful to maintain an optimum work environment.
 - Be sure to ground the body when handling the LCD module.
 - Tools required for assembly, such as soldering irons, must be properly grounded.
 - To reduce the amount of static electricity generated, do not conduct assembly and other work under dry conditions.
 - The LCD module is coated with a film to protect the display surface. Exercise care when peeling off this protective film since static electricity may be generated.
- Storage precautions
When storing the LCD modules, avoid exposure to direct sunlight or to the light of fluorescent lamps. Keep the modules in bags designed to prevent static electricity charging under low temperature / normal humidity conditions (avoid high temperature / high humidity and low temperatures below 0°C). Whenever possible, the LCD modules should be stored in the same conditions in which they were shipped from our company.

18. OTHERS

- Liquid crystals solidify at low temperature (below the storage temperature range) leading to defective orientation of liquid crystal or the generation of air bubbles (black or white). Air bubbles may also be generated if the module is subjected to a strong shock at a low temperature.
- If the LCD modules have been operating for a long time showing the same display patterns may remain on the screen as ghost images and a slight contrast irregularity may also appear. Abnormal operating status can be resumed to be normal condition by suspending use for some time. It should be noted that this phenomena does not adversely affect performance reliability.
- To minimize the performance degradation of the LCD modules resulting from caused by static electricity, etc. exercise care to avoid holding the following sections when handling the modules:
 - Exposed area of the printed circuit board
 - Terminal electrode sections.