

DISPLAY Elektronik GmbH

DATA SHEET

LCD MODULE

DEM 128064P FGH-PW

Product Specification

Version: 3.1.3

25.02.2019

GENERAL SPECIFICATION

MODULE NO. :

DEM 128064P FGH-PW

CUSTOMER P/N:

Version No.	Change Description	Date
0	Original Version	09.11.2012
1	Update	12.11.2012
2	Update	21.11.2012
3	Update	11.12.2012
3.1.0	New Production Line	24.04.2018
3.1.1	Correct the FPC Dimension in the module drawing on page 3 Add the lifetime to the BL drawing on page 5	02.04.2018
3.1.2	Change the BL drawing on page 5	05.06.2018
3.1.3	Add the double tape in the BL drawing	25.02.2019

PREPARED BY: PS

DATE: 25.02.2019

APPROVED BY: MHI

DATE: 25.02.2019

CONTENTS

1. FUNCTIONS & FEATURES2

2. MECHANICAL SPECIFICATIONS.....2

3. EXTERNAL DIMENSIONS.....3

4. BLOCK DIAGRAM.....4

5. PIN DESCRIPTION.....4

6. BACKLIGHT DRAWING5

7. ABSOLUTE MAXIMUM RATINGS6

8. ELECTRICAL CHARACTERISTICS6

9.LCD ELECTRICAL& OPTICAL CHARACTERISTICS7

10. COMMAND TABLE10

11. LCD ARTWORK..... 11

12. COMMON LAYOUT 11

13. SEGMENT LAYOUT.....12

14. IC LAYOUT12

15. ACCEPT QUALITY LEVEL (AQL).....13

16. RELIABILITY TEST.....13

17. LCD MODULES HANDLING PRECAUTIONS.....14

18. OTHERS.....14

1. FUNCTIONS & FEATURES

MODULE NAME	LCD TYPE	Remark
DEM 128064P FGH-PW	FSTN Transflective Positive	---

Viewing Direction	: 6 O'clock
Driving Scheme	: 1/65 Duty Cycle, 1/9 Bias
Supply voltage	: 3.3 Volt (typ.)
LCD Operation Voltage	: 9.0 Volt (typ.)
Driver IC	: ST7567 (Sitronix)
Interface	: 4-Line-SPI

2. MECHANICAL SPECIFICATIONS

Module Size	: 37.00 x 30.30 x 7.10 mm
Viewing Area	: 31.40 x 20.30 mm
Active Area	: 27.50 x 15.98 mm
Dot Size	: 0.195 x 0.23 mm
Dot Gap	: 0.02 mm

4. BLOCK DIAGRAM

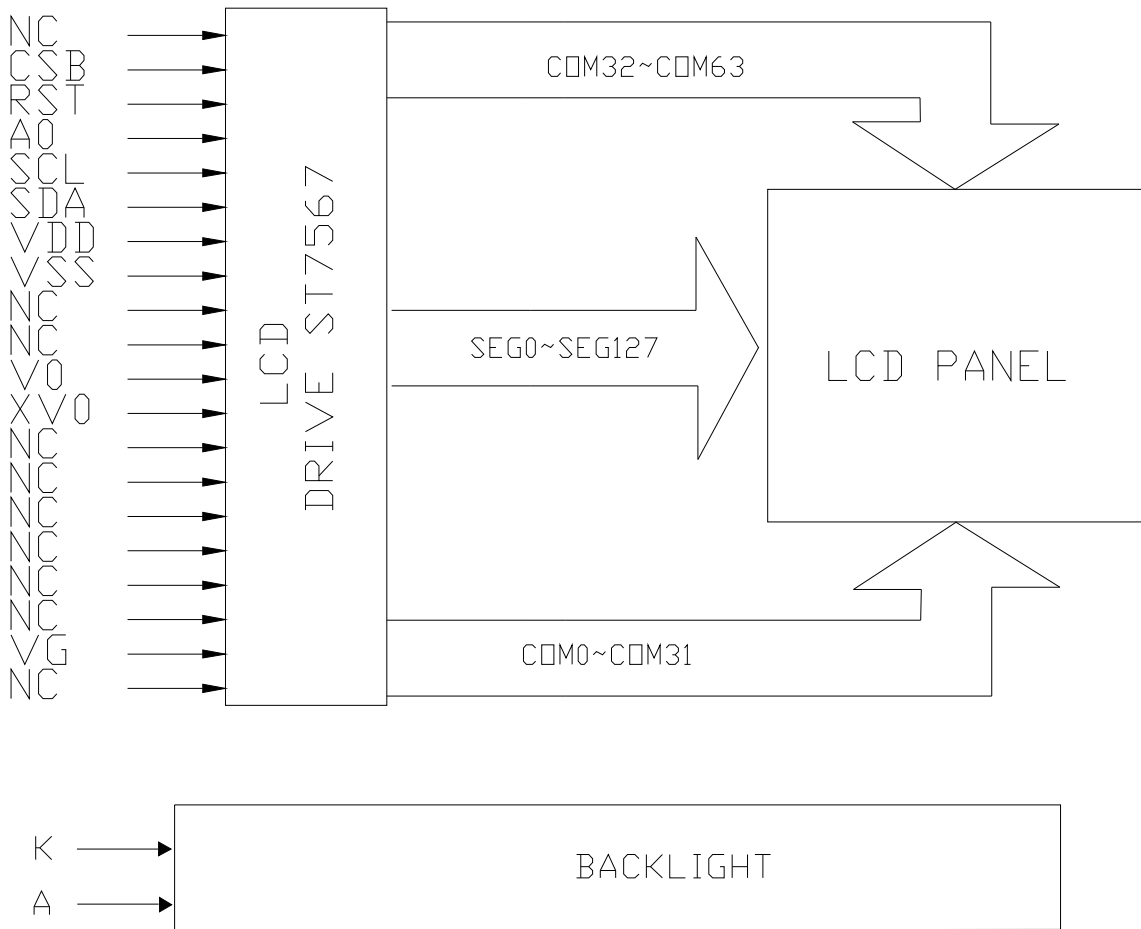

5. PIN DESCRIPTION

Pin No.	Name	Description
1	NC	No Connection
2	CSB	Chip select input pin. Interface access is enabled when CSB is "L". When CSB is non-active (CSB="H"), D[7:0] pins are high impedance.
3	RST	Hardware reset input pin. When RSTB is "L", internal initialization is executed and the internal registers will be initialized.
4	A0	It determines whether the access is related to data or command. A0="H": Indicates that signals on D[7:0] are display data. A0="L": Indicates that signals on D[7:0] are command.
5	SCL	Serial clock input.
6	SDA	Serial data input.
7	VDD	Power Supply
8	VSS	Ground level
9~10	NC	No Connection
11	V0	V0 is the LCD driving voltage for common circuits at negative frame
12	XV0	XV0 is the LCD driving voltage for common circuits at positive frame.
13~18	NC	No Connection
19	VG	VG is the LCD driving voltage for segment circuits.
20	NC	No Connection

6. Backlight Drawing

Item	Symbol	mi n.	typ.	max.	Uni t	Condi tion
Forward Vol tage	Vf	2.9	3.1	3.3	V	If= 30 mA T=25° C
Power Di ssi pati on	Pd	87	93	99	mW	
Lumi nous Uni formi ty	Δ Lv	75			%	
Lumi nance	Lv	400	500		cd/m ²	
Lumi nance Intensi ty (wi th LCD)	Lv	60	93		cd/m ²	
Col or Coordi nate	X	0.260		0.30		
	Y	0.260		0.30		
Li feti me		50000(bri ghtness reduce hal f)			hours	

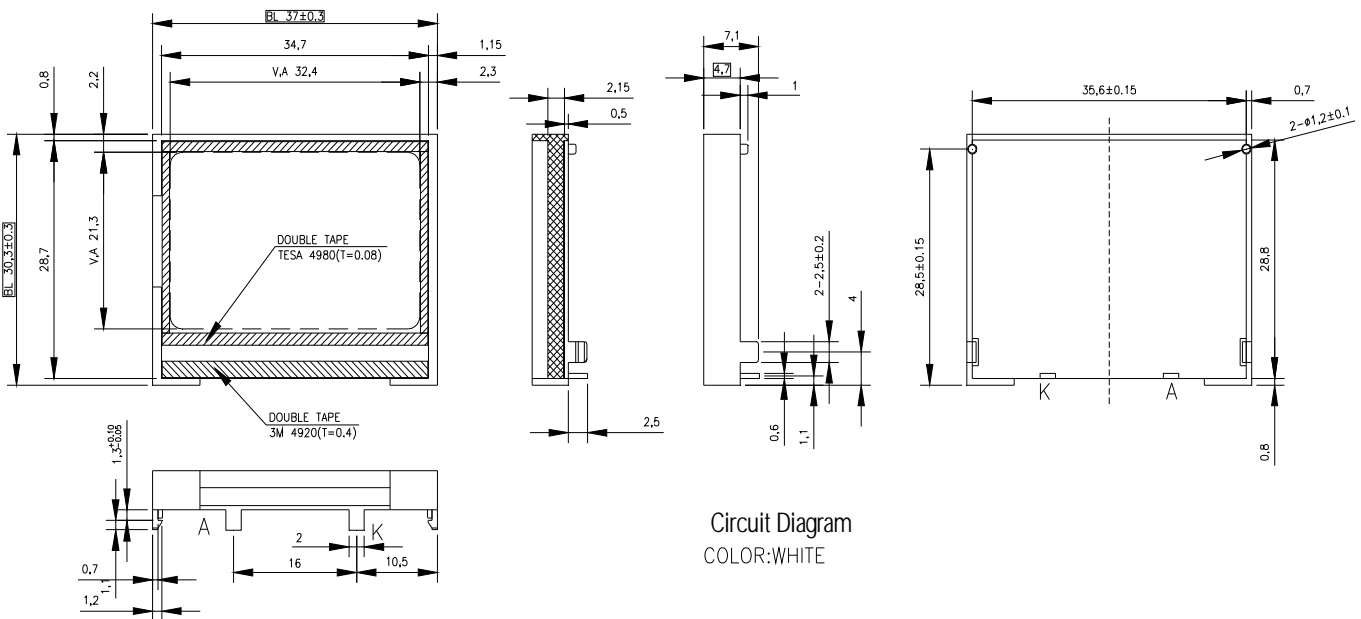

Circuit Diagram
COLOR:WHITE

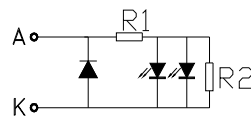

Remarks:
 1.Unmarked tolerance is ±0.3
 2.All materials comply with RoHs
 3. []critical dimension.

7. ABSOLUTE MAXIMUM RATINGS

Parameter	Symbol	Conditions	Unit
Power Supply Voltage	VDD	-0.3 ~ 4.0	V
LCD Power Supply Voltage	V0-XV0	-0.3 ~ 16	V
LCD Power Supply Voltage	VG	-0.3 ~ 4.0	V
Input Voltage	Vi	-0.3 ~ VDD+0.3	V
Operating Temperature	TOPR	-20 to +70	°C
Storage Temperature	TSTR	-30 to +80	°C

8. ELECTRICAL CHARACTERISTICS

8-1 DC CHARACTERISTICS

Item	Symbol	Condition	Standard Value			Units
			Min.	Typ.	Max.	
Operating Voltage	V _{DD}	VDD - VSS	3.0	3.3	3.6	V
LCD Driving Voltage	V _{LCD}	V0-VX0	8.7	9.0	9.3	
Input Voltage	H level	V _{IH}	-	-	VDD	
	L level	V _{IL}	-	-	0.3VDD	
Consumption Current	I _{DD}	-	-	TBD	-	mA

8-2 AC ELECTRICAL CHARACTERISTICS

System Bus Timing for 4-Line Serial Interface

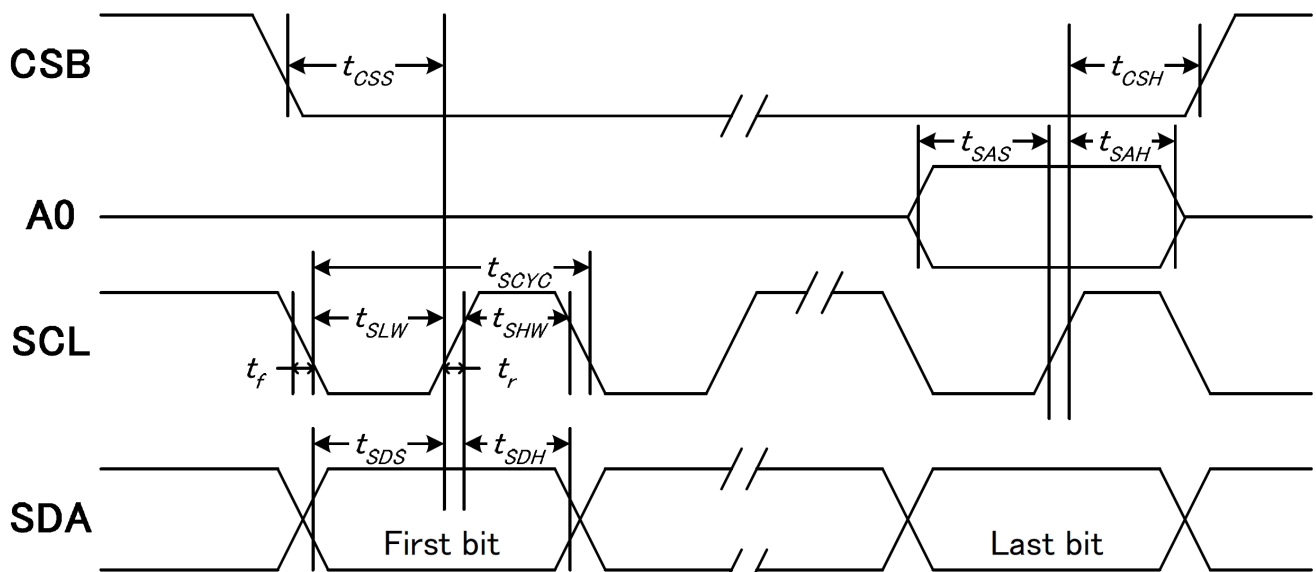

Item	Signal	Symbol	Condition	Min.	Max.	Unit
Serial clock period	SCLK	tSCYC		50	—	ns
SCLK "H" pulse width		tSHW		25	—	
SCLK "L" pulse width		tSLW		25	—	
Address setup time	A0	tSAS		20	—	
Address hold time		tSAH		10	—	
Data setup time	SDA	tSDS		20	—	
Data hold time		tSDH		10	—	
CSB-SCLK time	CSB	tCSS		20	—	
CSB-SCLK time		tCSH		40	—	

9. LCD ELECTRICAL & OPTICAL CHARACTERISTICS

Item	Symbol	Description	Condition	Temp.	Min.	Typ.	Max.	Unit
Operating Voltage for LCD	Vop	---	---	-20°C	---	---	---	V
		---	---	25°C	9.0	9.2	9.5	
		---	---	70°C	---	---	---	
Contrast	Cr	---	---	25°C	2	4	---	---
Viewing Angle	θ	3 o'clock axis ($\varphi=90^\circ$)	$Cr \geq 2.0$ $V_{DD}=3.3V \pm 3\%$	25°C	30	35	---	deg
		6 o'clock axis ($\varphi=0^\circ$)			35	45	---	
		9 o'clock axis ($\varphi=270^\circ$)			30	35	---	
		12 o'clock axis ($\varphi=180^\circ$)			35	40	---	
Response Time	T_r	Rise	$V_{DD}=3.3V \pm 3\%$	25°C	---	200	---	ms
	T_f	Fall	$V_{DD}=3.3V \pm 3\%$	25°C	---	220	---	

9.1 Definition of characteristics.

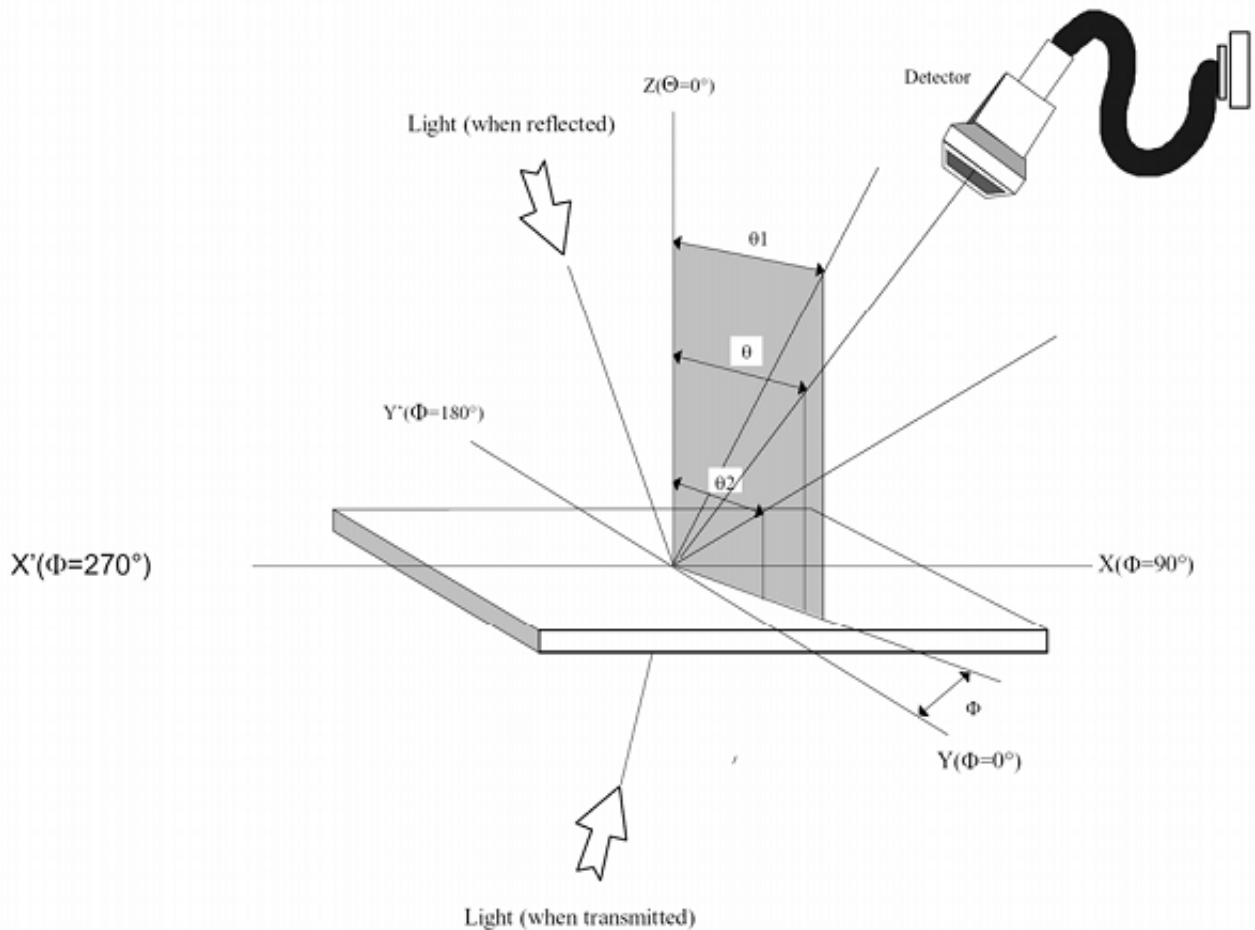

Definition of contrast $Cr. = \frac{B2}{B1} = \frac{\text{Bright curve of not selected segment}}{\text{Bright curve of selected segment}}$

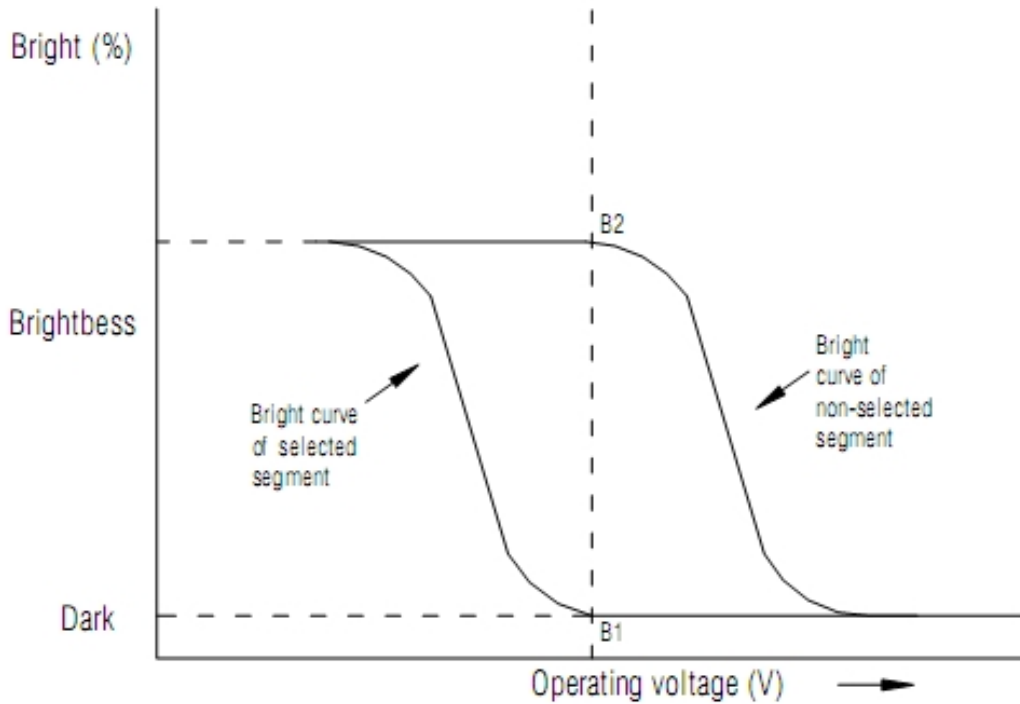

Definition of viewing angle $\theta 1$ and $\theta 2$

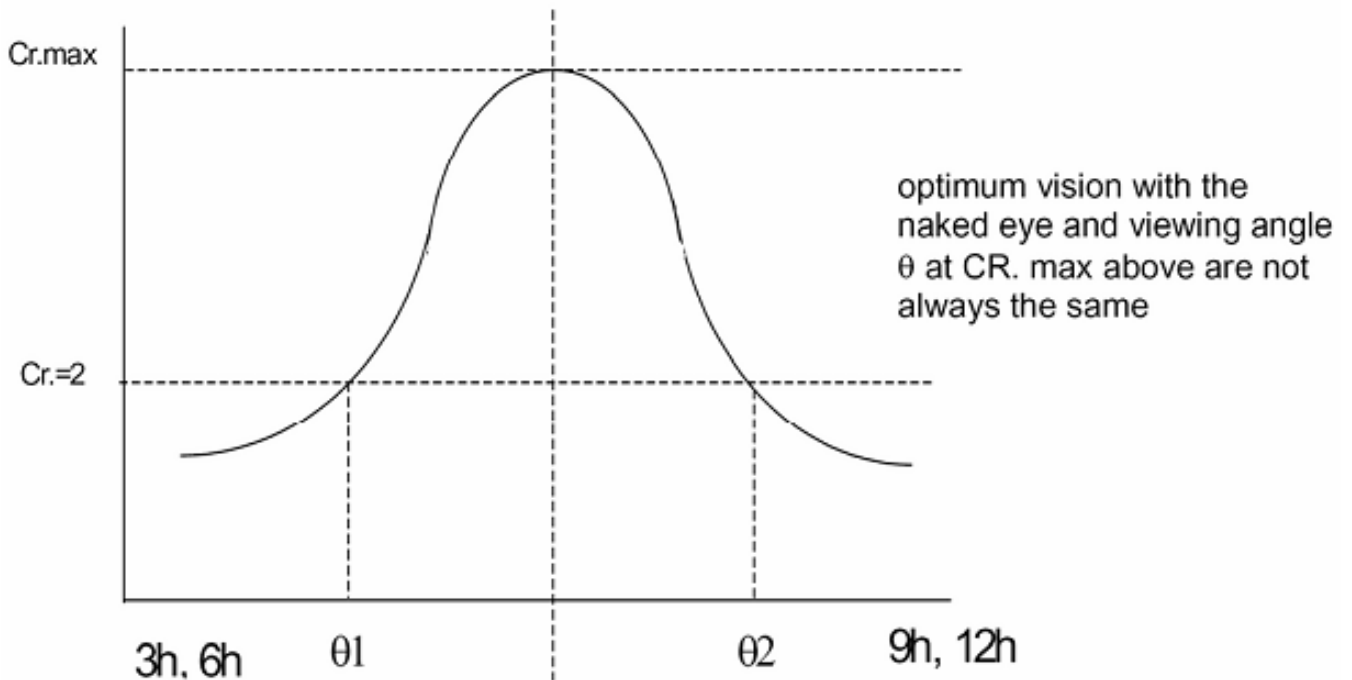

9.2 Definition of Response Time

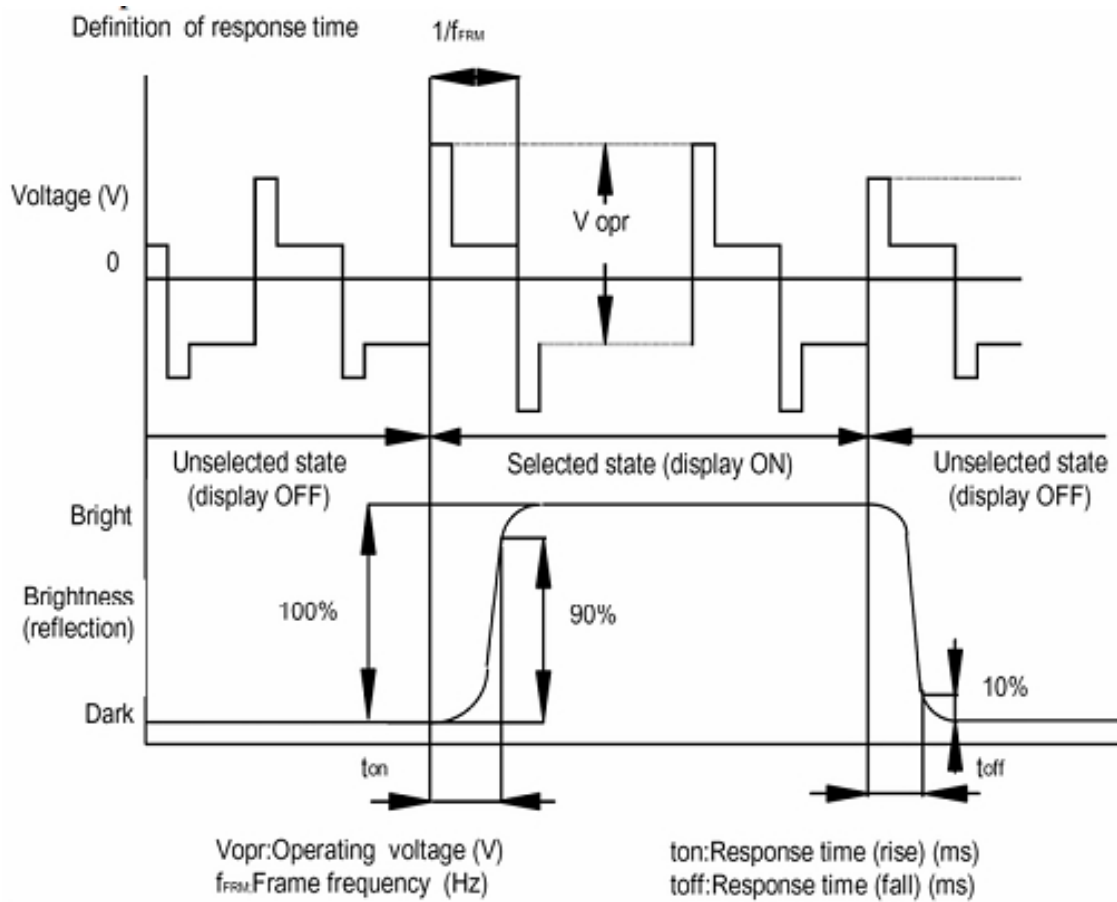

10. COMMAND TABLE

INSTRUCTION	A0	R/W (RWR)	COMMAND BYTE								DESCRIPTION	
			D7	D6	D5	D4	D3	D2	D1	D0		
(1) Display ON/OFF	0	0	1	0	1	0	1	1	1	1	D	D=1, display ON D=0, display OFF
(2) Set Start Line	0	0	0	1	S5	S4	S3	S2	S1	S0		Set display start line
(3) Set Page Address	0	0	1	0	1	1	Y3	Y2	Y1	Y0		Set page address
(4) Set Column Address	0	0	0	0	0	1	X7	X6	X5	X4		Set column address (MSB)
	0	0	0	0	0	0	X3	X2	X1	X0		Set column address (LSB)
(5) Read Status	0	1	0	MX	D	RST	0	0	0	0		Read IC Status
(6) Write Data	1	0	D7	D6	D5	D4	D3	D2	D1	D0		Write display data to RAM
(7) Read Data	1	1	D7	D6	D5	D4	D3	D2	D1	D0		Read display data from RAM
(8) SEG Direction	0	0	1	0	1	0	0	0	0	0	MX	Set scan direction of SEG MX=1, reverse direction MX=0, normal direction
(9) Inverse Display	0	0	1	0	1	0	0	1	1	INV		INV =1, inverse display INV =0, normal display
(10) All Pixel ON	0	0	1	0	1	0	0	1	0	AP		AP=1, set all pixel ON AP=0, normal display
(11) Bias Select	0	0	1	0	1	0	0	0	1	BS		Select bias setting 0=1/9; 1=1/7 (at 1/65 duty)
(12) Read-modify-Write	0	0	1	1	1	0	0	0	0	0		Column address increment: Read:+0 , Write:+1
(13) END	0	0	1	1	1	0	1	1	1	0		Exit Read-modify-Write mode
(14) RESET	0	0	1	1	1	0	0	0	1	0		Software reset
(15) COM Direction	0	0	1	1	0	0	MY	-	-	-		Set output direction of COM MY=1, reverse direction MY=0, normal direction
(16) Power Control	0	0	0	0	1	0	1	VB	VR	VF		Control built-in power circuit ON/OFF
(17) Regulation Ratio	0	0	0	0	1	0	0	RR2	RR1	RR0		Select regulation resistor ratio
(18) Set EV	0	0	1	0	0	0	0	0	0	1		Double command!! Set electronic volume (EV) level
	0	0	0	0	EV5	EV4	EV3	EV2	EV1	EV0		
(19) Set Booster	0	0	1	1	1	1	1	0	0	0		Double command!! Set booster level: BL=0: 4X BL=1: 5X
	0	0	0	0	0	0	0	0	0	BL		
(20) Power Save	0	0	Compound Command									Display OFF + All Pixel ON
(21) NOP	0	0	1	1	1	0	0	0	1	1		No operation
(22) Test	0	0	1	1	1	1	1	1	1	-		Do NOT use. Reserved for testing.

Note: Symbol "-" means this bit can be "H" or "L".

11. LCD ARTWORK

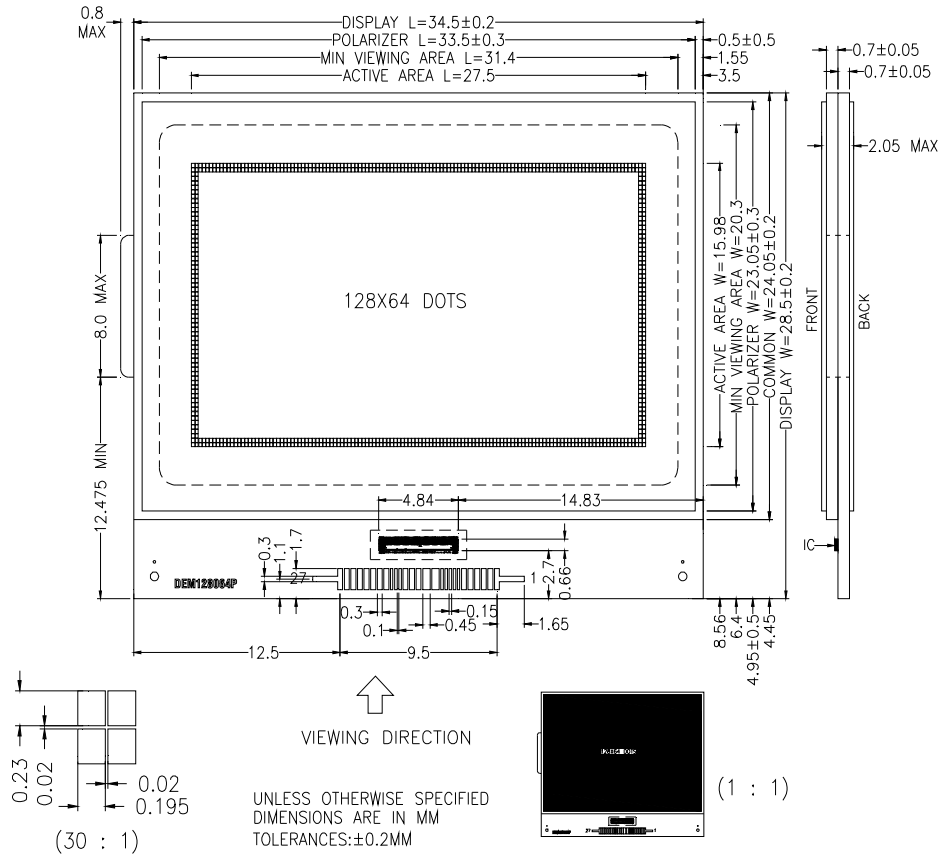

12. COMMON LAYOUT

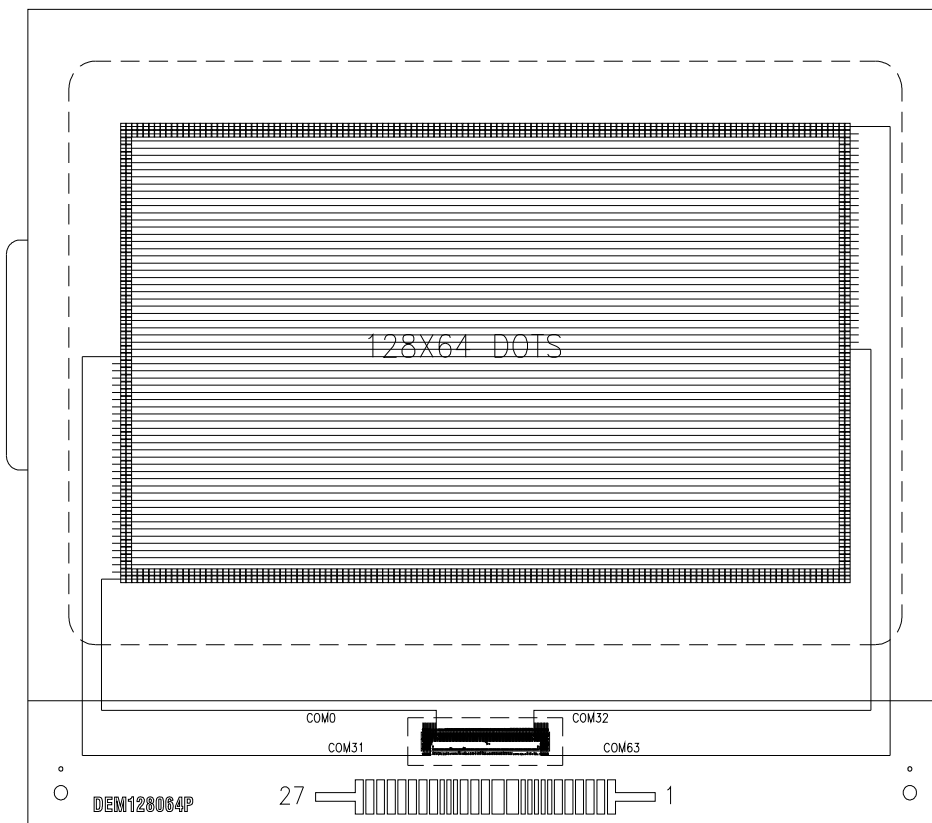

15. ACCEPT QUALITY LEVEL (AQL)

AQL Standard Value: Critical Defect =0.1, Major Defect=0.65; Minor Defect =2.5.

16. RELIABILITY TEST

Operating Lifetime: Longer than 50000 hours (at room temperature without direct irradiation of sunlight)
Reliability characteristics shall meet following requirements.

Test Item	Test Condition
High Temperature Storage	+80°C x 96hrs
Low Temperature Storage	-30°C x 96hrs
High Temperature Operation	+70°C x 96hrs
Low Temperature Operation	-20°C x 96hrs
High Temperature, High Humidity (Storage)	+70°C x 90%RH x 96hrs
Thermal Shock	-20°C x 30min → +25°C x 10s → +70°C x 30min 5 Cycles
Vibration Test	Frequency x Swing x Time 40Hz x 4mm x 4hrs
Drop Test	Drop Height x No. of drops 1.0m x 6 drops

17. LCD MODULES HANDLING PRECAUTIONS

- n** The display panel is made of glass. Do not subject it to a mechanical shock by dropping it from a high place, etc.
- n** If the display panel is damaged and the liquid crystal substance inside it leaks out, do not get any in your mouth. If the substance come into contact with your skin or clothes promptly wash it off using soap and water.
- n** Do not apply excessive force to the display surface or the adjoining areas since this may cause the color tone to vary.
- n** The polarizer covering the display surface of the LCD module is soft and easily scratched. Handle this polarize carefully.
- n** To prevent destruction of the elements by static electricity, be careful to maintain an optimum work environment.
 - Be sure to ground the body when handling the LCD module.
 - Tools required for assembly, such as soldering irons, must be properly grounded.
 - To reduce the amount of static electricity generated, do not conduct assembly and other work under dry conditions.
 - The LCD module is coated with a film to protect the display surface. Exercise care when peeling off this protective film since static electricity may be generated.
- n** Storage precautions
When storing the LCD modules, avoid exposure to direct sunlight or to the light of fluorescent lamps. Keep the modules in bags designed to prevent static electricity charging under low temperature / normal humidity conditions (avoid high temperature / high humidity and low temperatures below 0°C). Whenever possible, the LCD modules should be stored in the same conditions in which they were shipped from our company.

18. OTHERS

- n** Liquid crystals solidify at low temperature (below the storage temperature range) leading to defective orientation of liquid crystal or the generation of air bubbles (black or white). Air bubbles may also be generated if the module is subjected to a strong shock at a low temperature.
- n** If the LCD modules have been operating for a long time showing the same display patterns may remain on the screen as ghost images and a slight contrast irregularity may also appear. Abnormal operating status can be resumed to be normal condition by suspending use for some time. It should be noted that this phenomena does not adversely affect performance reliability.
- n** To minimize the performance degradation of the LCD modules resulting from caused by static electricity, etc. exercise care to avoid holding the following sections when handling the modules :
 - Exposed area of the printed circuit board
 - Terminal electrode sections