

DISPLAY Elektronik GmbH

DATA SHEET

LCD MODULE

DEM 128044A FGH-PW

Product Specification

Version: 6

06/Sep/2016

GENERAL SPECIFICATION

MODULE NO. :

DEM 128044A FGH-PW

CUSTOMER P/N:

Version No.	Change Description	Date
0	Original version	16.07.2009
1	Add version(Change FPC)	03.01.2013
2	Change UL number	22.05.2013
3	Add Version	09.12.2013
4	Add Customer P/N and Temperature	11.12.2013
5	Update Spec	19.10.2015
6	Adding current consumption	06.09.2016

PREPARED BY: GJ

DATE: 06.09.2016

APPROVED BY: MHO

DATE: 06.09.2016

CONTENTS

1. FUNCTIONS & FEATURES..... 2

2. MECHANICAL SPECIFICATIONS 2

3. EXTERNAL DIMENSIONS 3

4. BLOCK DIAGRAM 4

5. PIN DESCRIPTION 4

6. BACKLIGHT ELECTRICAL/OPTICAL SPECIFICATIONS 5

7. ABSOLUTE MAXIMUM RATINGS 6

8. ELECTRICAL CHARACTERISTICS..... 6

9. COMMAND TABLE 8

13. LCD MODULES HANDLING PRECAUTIONS 9

14. OTHERS..... 9

1. FUNCTIONS & FEATURES

Module	LCD TYPE	Remark
DEM 128044A FGH-PW	FSTN Transflective Positive Mode	---

- Viewing Direction : 6 O'clock
- Driving Scheme : 1/49 Duty Cycle, 1/8 Bias
- Power Supply Voltage : 3.3 Volt (typ.)
- LCD Operation Voltage (V0-Vss) : 9.0 Volt (typ.)
- Display Contents : 128x 44 Dots
- Driver IC : ST7565P-F1
- Interface : SPI
- Operating Temperature : -20°C to +70°C
- Storage Temperature : -30°C to +80°C
- RoHS : Compliant

2. MECHANICAL SPECIFICATIONS

- Module Size : 40.00 x 17.15 x 5.50 mm (without FPC)
- Viewing Area : 31.00 x 11.80 mm
- Active Area : 28.77 x 9.88 mm
- Dot Size : 0.20 x 0.20 mm
- Dot Pitch : 0.225 x 0.225 mm
- Dot Gap : 0.025 mm

3. EXTERNAL DIMENSIONS

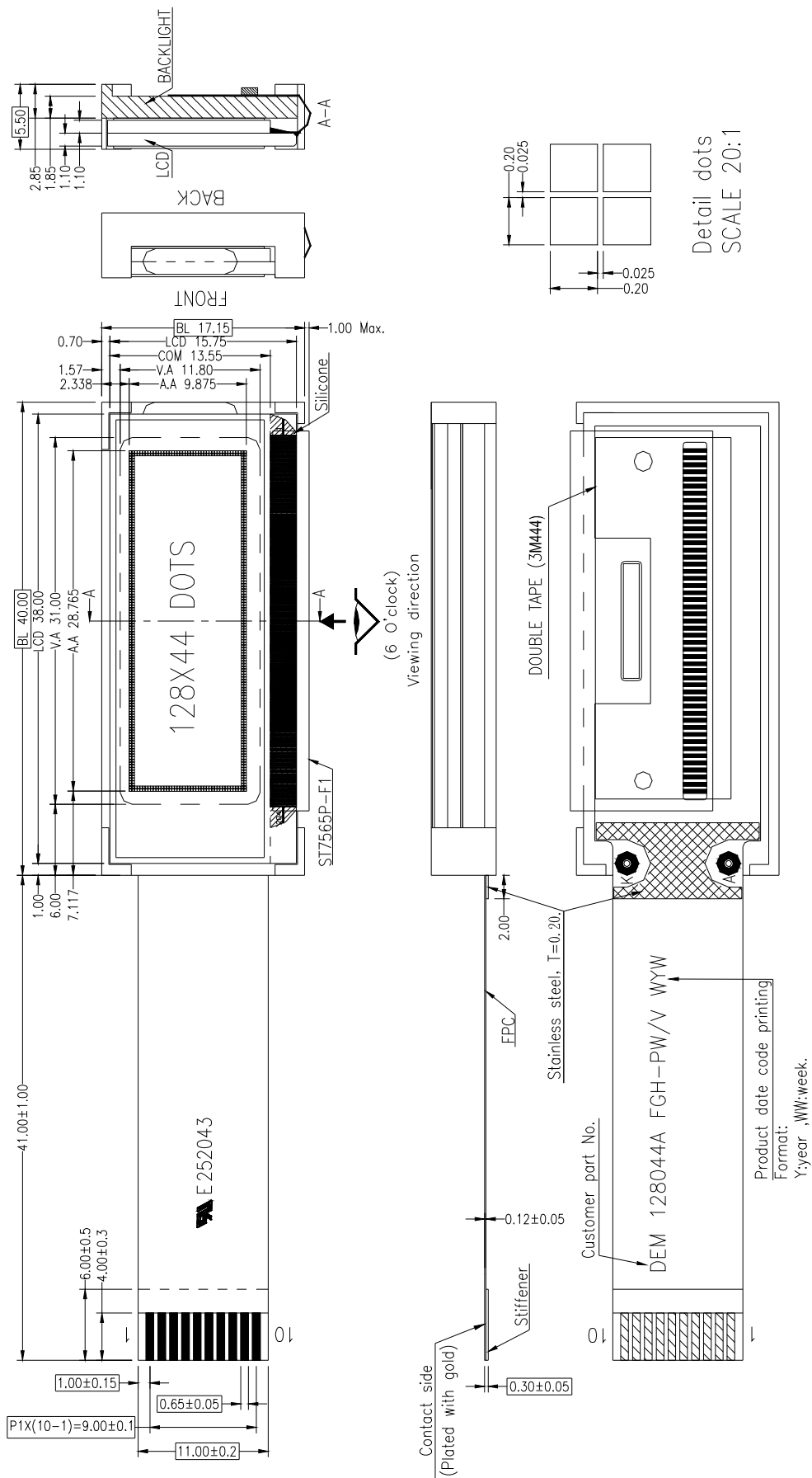

- Remarks:
1. Unmarked tolerance is ± 0.3
 2. All materials comply with RoHs
 3. \square ...:critical dimension.

4. BLOCK DIAGRAM

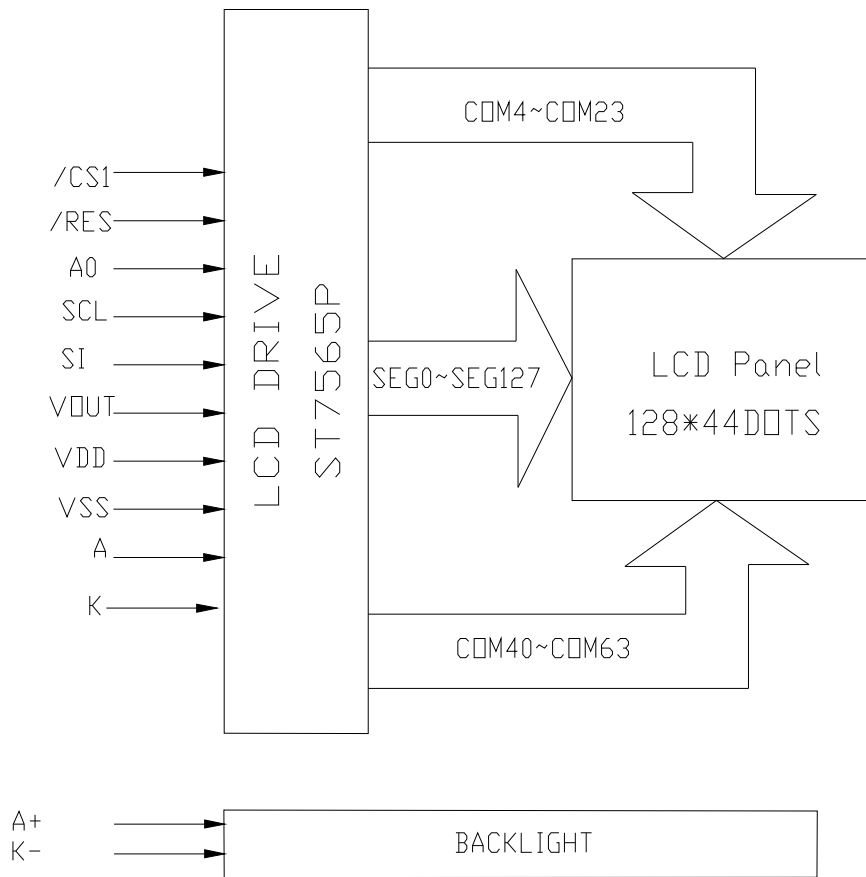

5. PIN DESCRIPTION

Pin No.	Name	Description
1	/CS1	This is the chip select signal. When /CS1="L", then the chip select becomes active, and data/command I/O is enabled.
2	/RES	When /RES is set to "L", the register settings are initialized(cleared). The reset operation is performed by the /RES signal level.
3	A0	This is connect to the least significant bit of the normal MPU address bus, and it determines whether the data bits are data or command. RS="H": Indicates that DB6 to DB7 are display data. RS="L": Indicates that DB6 to DB7 are control data.
4	SCL(D6)	Serial clock input.
5	SI(D7)	Serial data input .
6	VOUT	DC/DC voltage converter. A capacitor is connected between this terminal and VSS.
7	VDD	Voltage power supply.
8	VSS	Ground terminal.
9	A	It indicates backlight "+"signal input .
10	K	It indicates backlight "-" signal output.

6. BACKLIGHT ELECTRICAL/OPTICAL SPECIFICATIONS

ELECTRICAL–OPTICAL CHARACTERISTICS

Item	Symbol	min.	typ.	max.	Unit	Condition
Forward Voltage	Vf	2.8	3.1	3.3	V	If= 15 mA
Power Dissipation	Pd	-	-	-	mW	
Luminous Uniformity	DLv	70			%	MIN/MAX*100%
Luminance	Lv		400		cd/m ²	If= 15 mA T=25°C
Color Coordinate	X	0.250		0.330		
	Y	0.250		0.330		
Peak wave length	IP	-	-	-	nm	

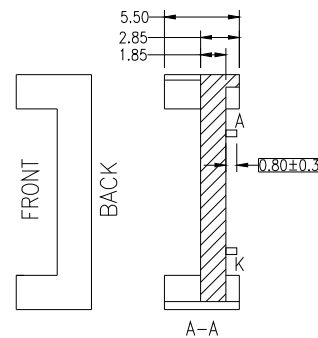
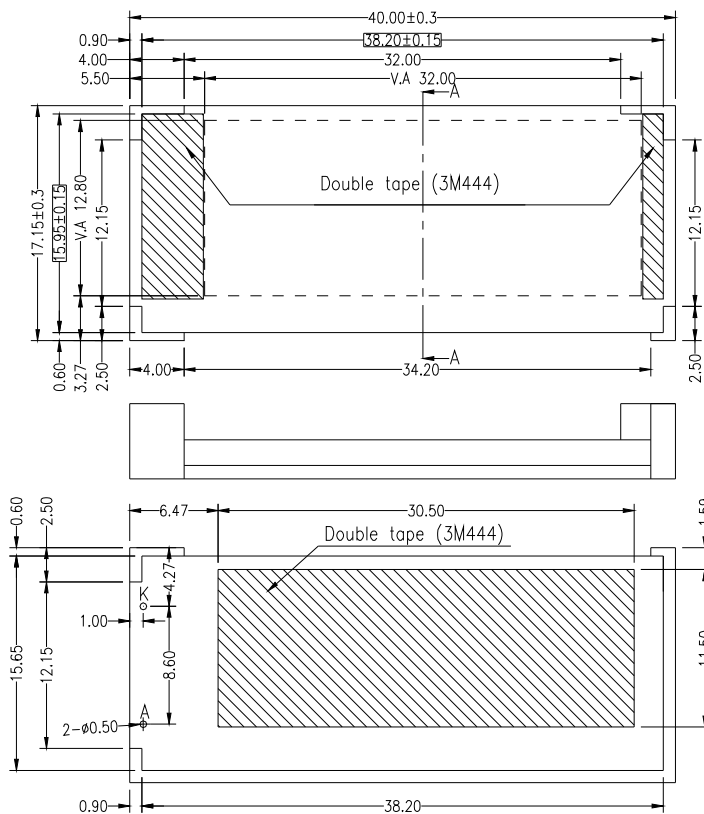

Remarks:

- 1.Unmarked tolerance is ±0.2
- 2.All materials comply with RoHs
3. []...:critical dimension.
- 4.THE COLOR IS WHITE
- 5.LED Life time 40000 hrs

Curcuit Diagram

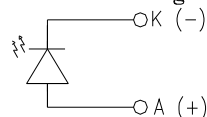

7. ABSOLUTE MAXIMUM RATINGS

Parameter	Symbol	Conditions	Unit	Remark
Power Supply Voltage(1)	V _{DD}	+2.4 to +3.6	V	
Power Supply Voltage (2)	V ₀ , V _{out}	+4.0 to +15.0	V	
Power Supply Voltage (3)	V1, V2,V3,V4	V ₀ ~0.3	V	
Operating Temperature	T _{OPR}	-20 to +70	°C	
Storage Temperature	T _{STR}	-30 to +80	°C	

8. ELECTRICAL CHARACTERISTICS

8.1 DC CHARACTERISTICS

PARAMETER	SYMBOL	STANDARD VALUE			TEST CONDITION	UNIT
		MIN	TYP	MAX	Condition	
Operation Voltage	V _{DD}	3.0	3.3	3.6	--	V
LCD Operation Voltage	V _{LCD}	8.7	9.0	9.3		V
Current Consumption	I _{DD}	--	163	224.5	Display pattern: snow	uA
			95	142.5	All ON/All OFF/Display Character	

8.2 AC ELECTRICAL CHARACTERISTICS.

The Serial Interface

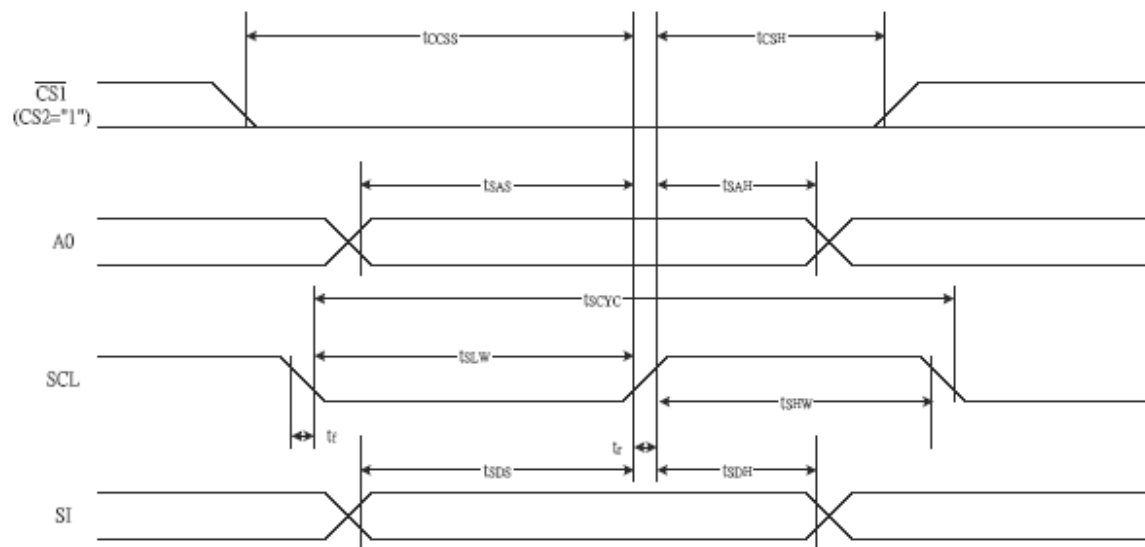

Item	Signal	Symbol	Condition	Rating		Units
				Min.	Max.	
Serial Clock Period	SCL	T _{scyc}		50	—	ns
SCL "H" pulse width		T _{shw}		25	—	
SCL "L" pulse width		T _{slw}		25	—	
Address setup time	A0	T _{sas}		20	—	
Address hold time		T _{сах}		10	—	
Data setup time	SI	T _{sds}		20	—	
Data hold time		T _{sdh}		10	—	
CS-SCL time	CS	T _{css}		20	—	
CS-SCL time		T _{csh}		40	—	

9. COMMAND TABLE

Command	Command Code								Function					
	A0	/RD	/WR	D7	D6	D5	D4	D3		D2	D1	D0		
(1) Display ON/OFF	0	1	0	1	0	1	0	1	1	1	0	1	LCD display ON/OFF 0: OFF, 1: ON	
(2) Display start line set	0	1	0	0	1	Display start address						Sets the display RAM display start line address		
(3) Page address set	0	1	0	1	0	1	1	Page address				Sets the display RAM page address		
(4) Column address set upper bit	0	1	0	0	0	0	1	Most significant column address				Sets the most significant 4 bits of the display RAM column address.		
Column address set lower bit	0	1	0	0	0	0	0	Least significant column address				Sets the least significant 4 bits of the display RAM column address.		
(5) Status read	0	0	1	Status				0	0	0	0	0	Reads the status data	
(6) Display data write	1	1	0	Write data								Writes to the display RAM		
(7) Display data read	1	0	1	Read data								Reads from the display RAM		
(8) ADC select	0	1	0	1	0	1	0	0	0	0	0	0	1	Sets the display RAM address SEG output correspondence 0: normal, 1: reverse
(9) Display normal/reverse	0	1	0	1	0	1	0	0	1	1	0	0	1	Sets the LCD display normal/reverse 0: normal, 1: reverse
(10) Display all points ON/OFF	0	1	0	1	0	1	0	0	1	0	0	0	1	Display all points 0: normal display 1: all points ON
(11) LCD bias set	0	1	0	1	0	1	0	0	0	1	0	0	1	Sets the LCD drive voltage bias ratio 0: 1/9 bias, 1: 1/7 bias (ST7565P)
(12) Read/modify/write	0	1	0	1	1	1	0	0	0	0	0	0	0	Column address increment At write: +1 At read: 0
(13) End	0	1	0	1	1	1	0	1	1	1	0	0	0	Clear read/modify/write
(14) Reset	0	1	0	1	1	1	0	0	0	1	0	0	0	Internal reset
(15) Common output mode select	0	1	0	1	1	0	0	0	1	*	*	*	*	Select COM output scan direction 0: normal direction 1: reverse direction
(16) Power control set	0	1	0	0	0	1	0	1	Operating mode			Select internal power supply operating mode		
(17) V ₀ voltage regulator internal resistor ratio set	0	1	0	0	0	1	0	0	Resistor ratio			Select internal resistor ratio(R _b /R _a) mode		
(18) Electronic volume mode set	0	1	0	1	0	0	0	0	0	0	0	0	1	Set the V ₀ output voltage
Electronic volume register set	0	1	0	0	0	Electronic volume value						electronic volume register		
(19) Static indicator ON/OFF	0	1	0	1	0	1	0	1	1	0	0	0	1	0: OFF, 1: ON
Static indicator register set	0	1	0	0	0	0	0	0	0	0	0	0	Mode	Set the flashing mode
(20) Booster ratio set	0	1	0	1	1	1	1	1	0	0	0	0	0	select booster ratio 00: 2x,3x,4x 01: 5x 11: 6x
(21) Power saver														Display OFF and display all points ON compound command
(22) NOP	0	1	0	1	1	1	0	0	0	1	1	1	1	Command for non-operation
(23) Test	0	1	0	1	1	1	1	*	*	*	*	*	*	Command for IC test. Do not use this command

10. LCD MODULES HANDLING PRECAUTIONS

- The display panel is made of glass. Do not subject it to a mechanical shock by dropping it from a high place, etc.
- If the display panel is damaged and the liquid crystal substance inside it leaks out, do not get any in your mouth. If the substance come into contact with your skin or clothes promptly wash it off using soap and water.
- Do not apply excessive force to the display surface or the adjoining areas since this may cause the color tone to vary.
- The polarizer covering the display surface of the LCD module is soft and easily scratched. Handle this polarize carefully.
- To prevent destruction of the elements by static electricity, be careful to maintain an optimum work environment.

-Be sure to ground the body when handling the LCD module.

-Tools required for assembly, such as soldering irons, must be properly grounded.

-To reduce the amount of static electricity generated, do not conduct assembly and other work under dry conditions.

-The LCD module is coated with a film to protect the display surface. Exercise care when peeling off this protective film since static electricity may be generated.

- **Storage precautions**

When storing the LCD modules, avoid exposure to direct sunlight or to the light of fluorescent lamps. Keep the modules in bags designed to prevent static electricity charging under low temperature / normal humidity conditions (avoid high temperature / high humidity and low temperatures below 0°C). Whenever possible, the LCD modules should be stored in the same conditions in which they were shipped from our company.

11. OTHERS

- Liquid crystals solidify at low temperature (below the storage temperature range) leading to defective orientation of liquid crystal or the generation of air bubbles (black or white). Air bubbles may also be generated if the module is subjected to a strong shock at a low temperature.
- If the LCD modules have been operating for a long time showing the same display patterns may remain on the screen as ghost images and a slight contrast irregularity may also appear. Abnormal operating status can be resumed to be normal condition by suspending use for some time. It should be noted that this phenomena does not adversely affect performance reliability.
- To minimize the performance degradation of the LCD modules resulting from caused by static electricity, etc. exercise care to avoid holding the following sections when handling the modules :
 - Exposed area of the printed circuit board
 - Terminal electrode sections