

Display Elektronik GmbH

DATA SHEET

TFT MODULE

**DEM 128160B TMH-PW-N
(C1-TOUCH)**

1,8" TFT + PCT

Product Specification

Ver.: 4

10.06.2023

Revision History

Revision	Date	Detail	Remarks
0	09.06.2017	Initial Release	-
1	19.10.2017	Modify Supply Voltage	P4/P5
2	21.08.2020	Modify CTP IC Modify Inspection Specification Modify Reliability Specification Modify Outline Drawing	P6 P19 P23 P27
3	29.10.2020	Modify Luminance On Modify Outline Drawing	P7 P27
4	10.06.2023	Modify Module Outline Modify Optical Glue Modify Packaging Modify Outline Drawing	P4 P6 P26 P27

Table of Contents

No.	Item	Page
1.	General Description.....	4
2.	Module Parameter.....	4
3.	Absolute Maximum Ratings.....	4
4.	DC Characteristics	5
5.	Backlight Characteristic.....	5
5.1.	Backlight Characteristic.....	5
5.2.	Backlight Characteristic.....	5
6.	Touch Screen Panel Specifications	6
7.	Optical Characteristics	7
7.1.	Optical Characteristics	7
7.2.	Definition of Response Time	7
7.3.	Definition of Contrast Ratio	8
7.4.	Definition of Viewing Angles.....	8
7.5.	Definition of Color Appearance	9
7.6.	Definition of Surface Luminance, Uniformity and Transmittance	9
8.	Block Diagram and Power Supply.....	10
9.	Interface Pins Definition	11
10.	AC Characteristics.....	12
10.1.	Reset timing.....	12
10.2.	Interface timing	13
11.	Quality Assurance	15
11.1.	Purpose	15
11.2.	Standard for Quality Test	15
11.3.	Nonconforming Analysis & Disposition	15
11.4.	Agreement Items	15
11.5.	Standard of the Product Visual Inspection.....	15
11.6.	Inspection Specification	16
11.7.	Classification of Defects	22
11.8.	Identification/marketing criteria	22
11.9.	Packaging	22
12.	Reliability Specification.....	23
13.	Precautions and Warranty.....	24
13.1.	Safety.....	24
13.2.	Handling.....	24
13.3.	Storage	24
13.4.	Metal Pin (Apply to Products with Metal Pins).....	24
13.5.	Operation.....	25
13.6.	Static Electricity.....	25
13.7.	Limited Warranty.....	25
14.	Outline Drawing.....	26

1. General Description

The specification is a transmissive type color active matrix liquid crystal display (LCD) which uses amorphous thin film transistor (TFT) as switching devices. This product is composed of a TFT-LCD panel, driver ICs, a touch panel and a backlight unit.

2. Module Parameter

Features	Details	Unit
Display Size (Diagonal)	1.77"	-
LCD Type	TN TFT	-
Display Mode	Transmissive / Normally White	-
Resolution	128 x RGB x 160	Pixels
View Direction	6 O'clock	Best Image
Gray Scale Inversion Direction	12 O'clock	-
Module Outline	40.70 x 52.75 x 4.20 (Note1)	mm
Active Area	28.03 x 35.04	mm
Pixel Size	0.219 x 0.219	mm
Pixel Arrangement	Stripe	-
Polarizer Surface Treatment	Anti-Glare	-
Display Colors	262k	-
Interface	MCU 8-Bit-Parallel MCU	-
With or without touch panel	With Projective Capacitive Touch	-
Driver IC	ILI9163V (Ilitek)	-
Operating Temperature	-20°C to +70°C	°C
Storage Temperature	-30°C to +80°C	°C
Weight	~ 13	g

Note 1: Exclusive hooks, posts, FFC/FPC tail etc.

3. Absolute Maximum Ratings

V_{SS}=0V, Ta=25°C

Item	Symbol	Min.	Max.	Unit	
Supply Voltage	Logic	IOVCC	-0.3	4.6	V
	Analog	VCC	-0.3	4.6	V
Storage Temperature	T _{STG}	-30	+80	°C	
Operating Temperature	T _{OP}	-20	+70	°C	

Note 1: If Ta below 50°C, the maximal humidity is 90%RH, if Ta over 50°C, absolute humidity should be less than 60%RH.

Note 2: The response time will be extremely slow when the operating temperature is around -10°C, and the back ground will become darker at high temperature operating.

4. DC Characteristics

Item		Symbol	Min.	Typ.	Max.	Unit
Supply Voltage	Logic	IOVCC	1.65	2.8	3.3	V
	Analog	VCC	2.5	2.8	4.0	V
Logic Low input voltage		V _{IL}	GND	-	0.3*IOVCC	V
Logic High input voltage		V _{IH}	0.7*IOVCC	-	IOVCC	V
Logic Low output voltage		V _{OL}	GND	-	0.2*IOVCC	V
Logic High output voltage		V _{OH}	0.8*IOVCC	-	IOVCC	V
Current Consumption All Black	Logic	I _{CC+ IIN}	-	(2)	(4)	mA
	Analog					

5. Backlight Characteristic

5.1. Backlight Characteristic

Item	Symbol	Condition	Min.	Typ.	Max.	Unit
Forward Voltage	V _F	T _a =25 °C, I _F =15mA/LED	2.8	3.1	3.3	V
Forward Current	I _F	T _a =25 °C, V _F =3.1V/LED	-	30	-	mA
Power Dissipation	P _D		-	93	-	mW
LED Lifetime (25 °C)	-	-	-	30000	-	Hrs
Uniformity	Avg		-	80	-	%
Drive Method	Constant Current					
LED Configuration	2 White LEDs in Parallel					

Note: LED life time defined as follows: The final brightness is at 50% of original brightness.

The environmental conducted under ambient air flow, at T_a=25°C±2 °C, 60%RH±5%, I_F=15mA

5.2. Backlight Characteristic

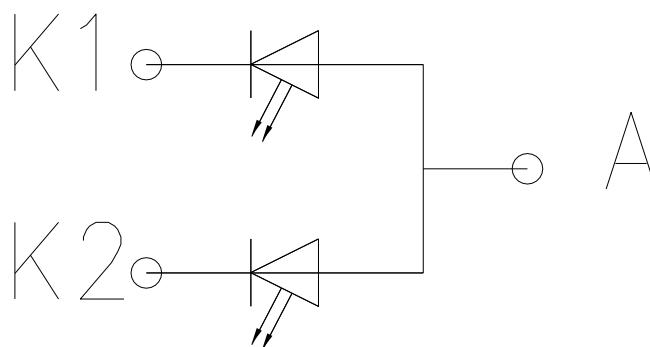

6. Touch Screen Panel Specifications

Item	CTP Description	
1	IC	FT6336U
2	Interface	I2C
3	Operating Voltage	2.8V ~ 3.3V
4	Interface Signal Voltage	2.8V ~ 3.3V
5	Surface Hardness	>6H
6	Operating Temperature	-20°C ~ +70°C
7	Storage Temperature	-30°C ~ +80°C
8	Strengthened Type	Chemical
9	Transmittance	>85%
10	Origin of Coordinates	T/L
11	Resolution Ratio	128 x 160

Item	Main Layer Define	Thickness/Material
1	Lens	0.70mm/Glass
2	Optical Glue	0.20mm
3	Sensor	0.55mm/Glass

7. Optical Characteristics

7.1. Optical Characteristics

Ta=25°C, VCC=2.8V, TN LC+ Polarizer

	Item	Symbol	Condition	Specification			Unit	
				Min.	Typ.	Max.		
Backlight On (Transmissive Mode)	Luminance on TFT ($I_f = 15\text{mA/LED}$)	Lv	Normally viewing angle $\theta_X = \phi_Y = 0^\circ$	360	450	-	cd/m ²	
	Contrast Ratio(See 6.3)	CR		400	500	-		
	Response Time (See 6.2)	TR+TF		-	8	16	ms	
	Chromaticity Transmissive (See 6.5)	Red	XR	Center CR≥10	0.553	0.603	0.653	
			YR		0.304	0.354	0.404	
		Green	XG		0.246	0.296	0.346	
			YG		0.571	0.621	0.671	
		Blue	XB		0.096	0.146	0.196	
			YB		0.039	0.089	0.139	
	White	XW	0.232	0.282	0.332			
		YW	0.282	0.332	0.382			
	Viewing Angle (See 6.4)	Horizontal	θ_{X+}	Center CR≥10	50	60	-	Deg.
			θ_{X-}		50	60	-	
Vertical		ϕ_{Y+}	50		60	-		
		ϕ_{Y-}	30		40	-		
NTSC Ratio(Gamut)				-	60	-	%	

7.2. Definition of Response Time

7.2.1. Normally Black Type (Negative)

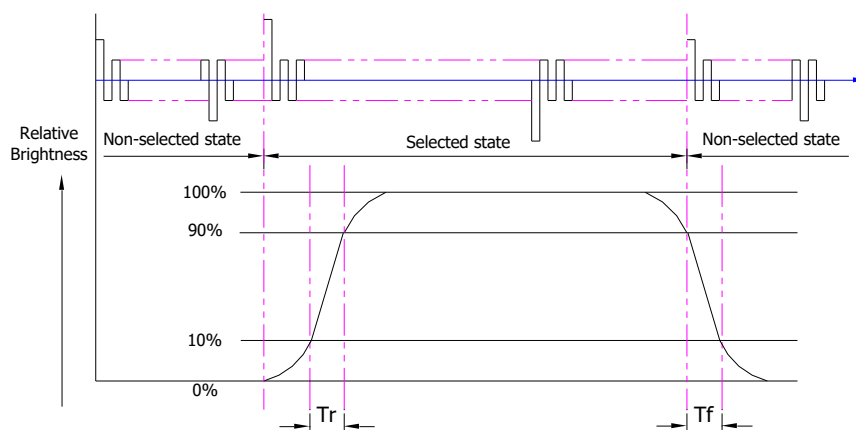

Tr is the time it takes to change from non-selected state with relative luminance 10% to selected state with relative luminance 90%;

Tf is the time it takes to change from selected state with relative luminance 90% to non-selected state with relative luminance 10%.

Note: Measuring machine: LCD-5100

7.2.2. Normally White Type (Positive)

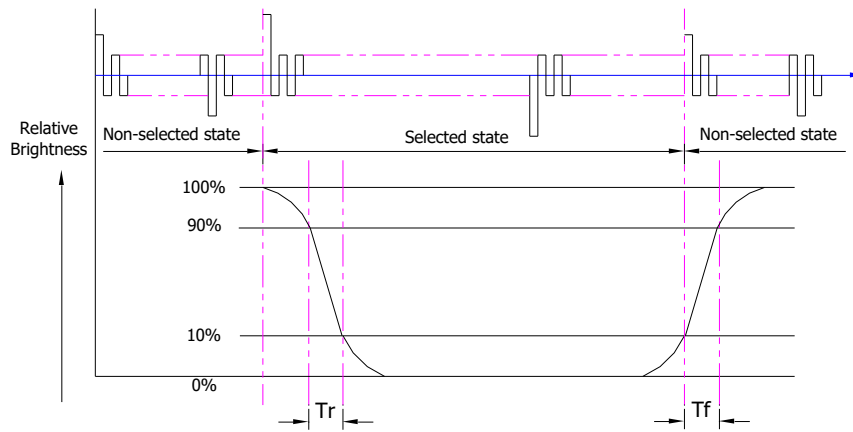

T_r is the time it takes to change from non-selected stage with relative luminance 90% to selected state with relative luminance 10%;

T_f is the time it takes to change from selected state with relative luminance 10% to non-selected state with relative luminance 90%;

Note: Measuring machine: LCD-5100 or EQUI

7.3. Definition of Contrast Ratio

Contrast is measured perpendicular to display surface in reflective and transmissive mode.

The measurement condition is:

Measuring Equipment	Eldim or Equivalent
Measuring Point Diameter	3mm//1mm
Measuring Point Location	Active Area centre point
Test pattern	A: All Pixels white
	B: All Pixel black
Contrast setting	Maximum

Definitions: CR (Contrast) = Luminance of White Pixel / Luminance of Black Pixel

7.4. Definition of Viewing Angles

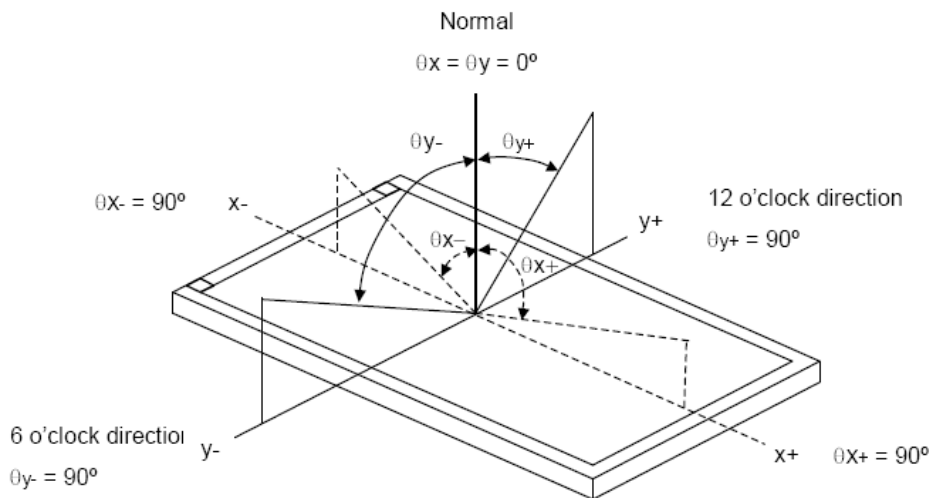

Measuring machine: LCD-5100 or EQUI

7.5. Definition of Color Appearance

R,G,B and W are defined by (x, y) on the IE chromaticity diagram

NTSC=area of RGB triangle/area of NTSC triangleX100%

Measuring picture: Red, Green, Blue and White (Measuring machine: BM-7)

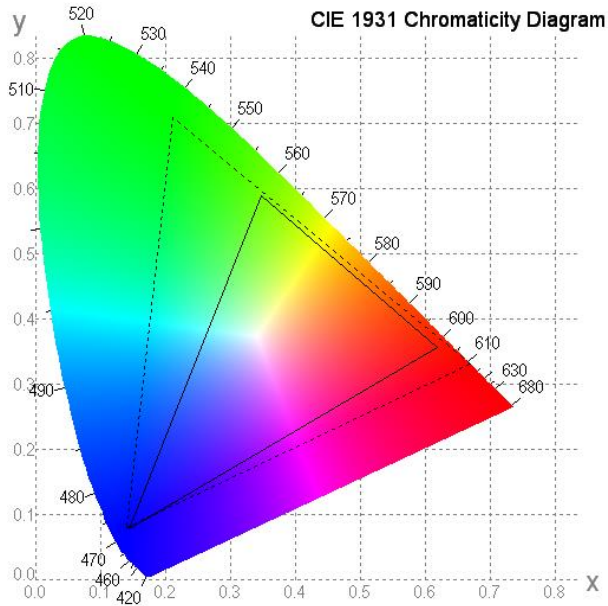

7.6. Definition of Surface Luminance, Uniformity and Transmittance

Using the transmissive mode measurement approach, measure the white screen luminance of the display panel and backlight.

7.6.1. Surface Luminance: $L_v = \text{average} (L_{P1}:L_{P9})$

7.6.2. Uniformity = $\text{Minimal} (L_{P1}:L_{P9}) / \text{Maximal} (L_{P1}:L_{P9}) * 100\%$

7.6.3. Transmittance = $L_v \text{ on LCD} / L_v \text{ on Backlight} * 100\%$

Note: Measuring machine: BM-7

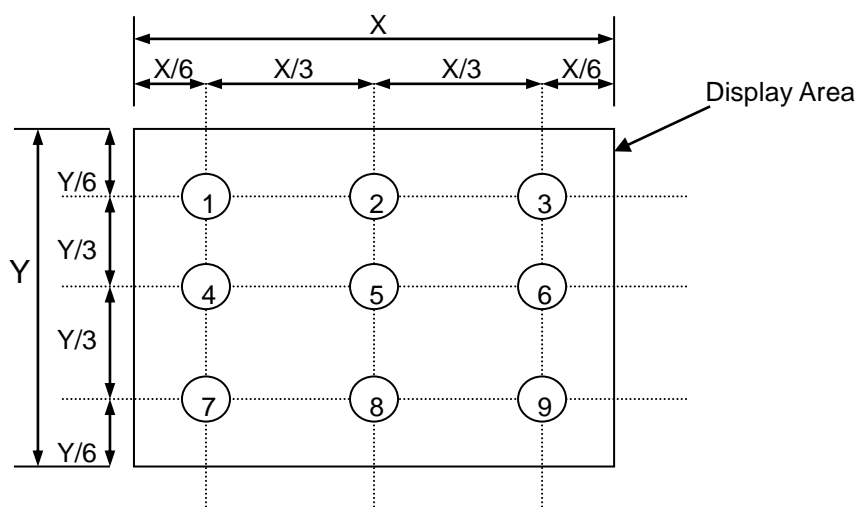

8. Block Diagram and Power Supply

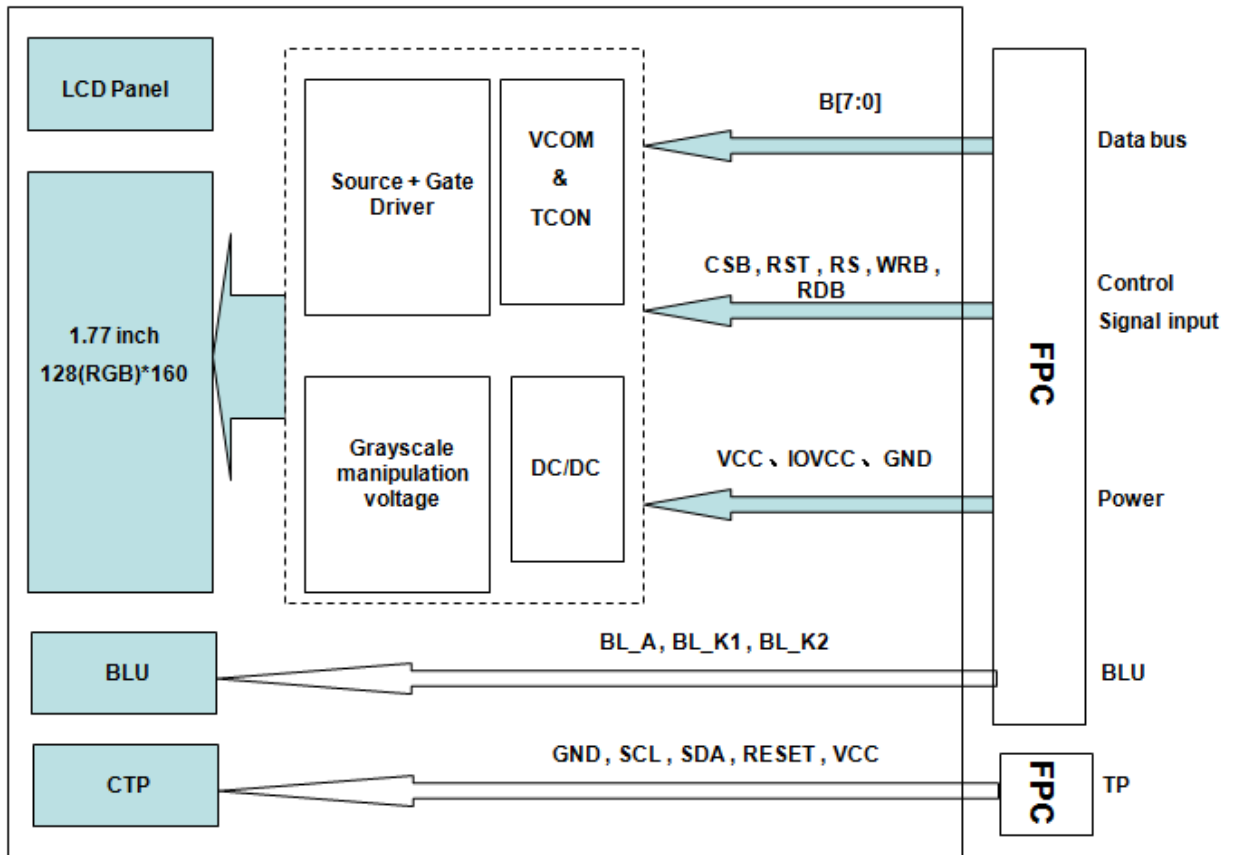

9. Interface Pins Definition**9.1 TFT PIN**

No.	Symbol	Function	Remark
1	GND	Ground	
2	IOVCC	Logic Power(1.8V)	
3	VCC	Analog Power(2.8V)	
4	CSB	Chip Select Signal	
5	RST	Reset Signal	
6	RS	Data/Command Signal	
7	WRB	Write signal	
8	RDB	Read signal	
9	DB0	Data bus	
10	DB1	Data bus	
11	DB2	Data bus	
12	DB3	Data bus	
13	DB4	Data bus	
14	DB5	Data bus	
15	DB6	Data bus	
16	DB7	Data bus	
17	BL_A	Led anode	
18	BL_K1	Led cathode	
19	BL_K2	Led cathode	
20	GND	Ground	

9.2 CTP PIN

No.	Symbol	Function	Remark
1	GND	Ground	
2	SCL	Clock	
3	SDA	Data	
4	INT	Interrupt	
5	RESET	Reset	
6	VCC	Power supply	

10. AC Characteristics

10.1. Reset timing

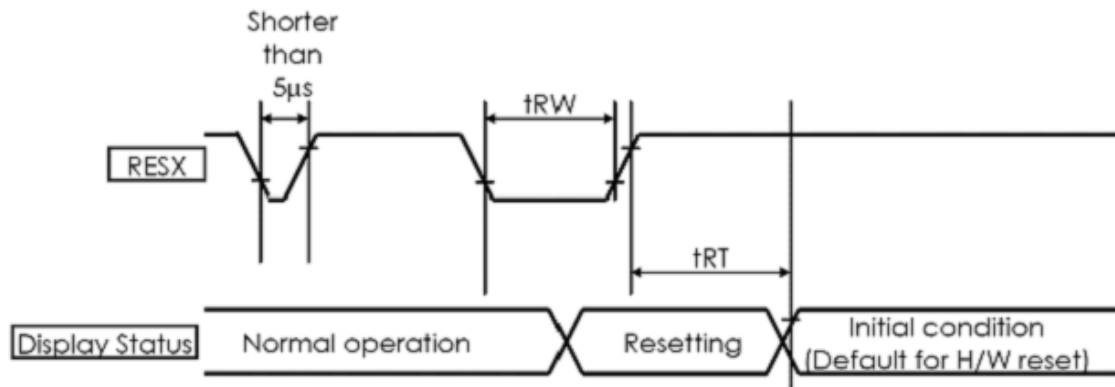

(VSS=0V, VDDI=1.65V to 1.95V, VPNL=2.6V to 2.9V, Ta = -30 to 70°C)

Symbol	Parameter	Related Pins	MIN	TYP	MAX	Note	Unit
tRESW	*1) Reset low pulse width	RESX	10	-	-	-	µs
tREST	*2) Reset complete width	-	-	-	5	When reset applied during Sleep in mode	ms
		-	-	-	120	When reset applied during Sleep out mode	ms

Note

1. Spike due to an electrostatic discharge on RESX line does not cause system reset according to the table below.

WRX	twc	Write cycle	66		ns	
	twrh	Control pulse H duration	15		ns	
	twrl	Control pulse L duration	15		ns	
RDX	trc	Read cycle (ID)	160		ns	When read ID data
	trdh	Control pulse H duration(ID)	90		ns	
	trdl	Control pulse L duration(ID)	45		ns	
RDX	trcfm	Read cycle (FM)	450		ns	When read from frame memory
	trdhfm	Control pulse H duration (FM)	90		ns	
	trdlfm	Control pulse L duration (FM)	355		ns	
D[17..0]	tdst	Data setup time	10		ns	For maximum CL = 30pF
	tdht	Data hold time	10		ns	
	trat	Read access time (ID)		40	ns	For minimum CL = 8pF
	tratfm	Read access time (FM)		340	ns	
	todh	Output disable time	20	80	ns	

Note 1: VDDI 1.65 to 3.3V, VDD=2.6 to 3.3V, AGND=GND=0V, Ta=-30 to 70 °C (to +85°C no damage)

Note 2: This input signal rise time and fall time (tr, tf) is specified at 15 ns or less. Logic high and low levels are specified as 30% and 70% of VDDI for input signals

11. Quality Assurance

11.1. Purpose

This standard for Quality Assurance assures the quality of LCD module products supplied to customer.

11.2. Standard for Quality Test

11.2.1 Sampling Plan:

GB2828.1-2012

Single sampling, general inspection level II

11.2.2 Sampling Criteria:

Visual inspection: AQL 1.5%

Electrical functional: AQL 0.65%.

11.2.3 Reliability Test:

Detailed requirement refer to Reliability Test Specification.

11.3. Nonconforming Analysis & Disposition

11.3.1 Nonconforming analysis:

11.3.1.1 Customer should provide overall information of non-conforming sample for their complaints.

11.3.1.2 After receipt of detailed information from customer, the analysis of nonconforming parts usually should be finished in one week.

11.3.1.3 If cannot finish the analysis on time, customer will be notified with the progress status.

11.3.2 Disposition of nonconforming:

11.3.2.1 Non-conforming product over PPM level will be replaced.

11.3.2.2 The cause of non-conformance will be analyzed. Corrective action will be discussed and implemented.

11.4. Agreement Items

Shall negotiate with customer if the following situation occurs:

11.4.1 There is any discrepancy in standard of quality assurance.

11.4.2 Additional requirement to be added in product specification.

11.4.3 Any other special problem.

11.5. Standard of the Product Visual Inspection

11.5.1 Appearance inspection:

11.5.1.1 The inspection must be under illumination about 1000 – 1500 lx, and the distance of view must be at 30cm ± 2cm.

11.5.1.2 The viewing angle should be 45° from the vertical line without reflection light or follows customer's viewing angle specifications.

11.5.1.3 Definition of area: A Zone: Active Area, B Zone: Viewing Area,

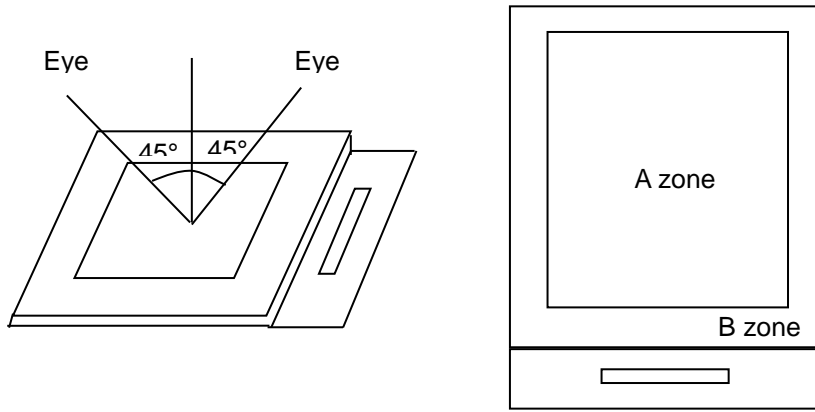

11.5.2 Basic principle:

11.5.2.1 A set of sample to indicate the limit of acceptable quality level must be discussed by both us and customer when there is any dispute happened.

11.5.2.2 New item must be added on time when it is necessary.

11.6. Inspection Specification

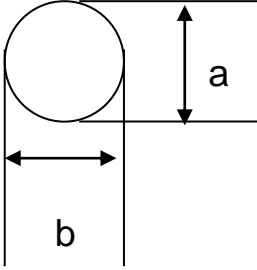
No.	Item	Criteria (Unit: mm)																		
01	Black / White spot Foreign material (Round type) Pinholes Stain Particles inside cell. (Minor defect)	 <p>$\phi = (a + b) / 2$</p> <table border="1" data-bbox="880 1012 1385 1352"> <thead> <tr> <th>Size</th> <th>Area</th> <th>Acc. Qty</th> </tr> </thead> <tbody> <tr> <td>$\phi \leq 0.10$</td> <td></td> <td>Ignore</td> </tr> <tr> <td>$0.10 < \phi \leq 0.15$</td> <td></td> <td>2</td> </tr> <tr> <td>$0.15 < \phi \leq 0.25$</td> <td></td> <td>1</td> </tr> <tr> <td>$0.25 < \phi$</td> <td></td> <td>0</td> </tr> <tr> <td>Total</td> <td></td> <td>2 no include $\phi \leq 0.10$</td> </tr> </tbody> </table> <p>Distance between 2 defects should more than 3mm apart.</p>	Size	Area	Acc. Qty	$\phi \leq 0.10$		Ignore	$0.10 < \phi \leq 0.15$		2	$0.15 < \phi \leq 0.25$		1	$0.25 < \phi$		0	Total		2 no include $\phi \leq 0.10$
Size	Area	Acc. Qty																		
$\phi \leq 0.10$		Ignore																		
$0.10 < \phi \leq 0.15$		2																		
$0.15 < \phi \leq 0.25$		1																		
$0.25 < \phi$		0																		
Total		2 no include $\phi \leq 0.10$																		
02	Electrical Defect (Minor defect)	<table border="1" data-bbox="555 1491 1375 1706"> <thead> <tr> <th></th> <th>Display Area</th> <th>Total</th> <th rowspan="3">Note1</th> </tr> </thead> <tbody> <tr> <td>Bright dot</td> <td>0</td> <td>0</td> </tr> <tr> <td>Dark dot</td> <td>$N \leq 2$</td> <td>$N \leq 2$</td> </tr> <tr> <td>Total dot</td> <td>$N \leq 2$</td> <td>$N \leq 2$</td> <td></td> </tr> <tr> <td>Mura</td> <td colspan="2">Not visible through 5% ND filters.</td> <td>Note 2</td> </tr> </tbody> </table> <p>Remark: 1. Bright dot caused by scratch and foreign object accords to item 1.</p>		Display Area	Total	Note1	Bright dot	0	0	Dark dot	$N \leq 2$	$N \leq 2$	Total dot	$N \leq 2$	$N \leq 2$		Mura	Not visible through 5% ND filters.		Note 2
	Display Area	Total	Note1																	
Bright dot	0	0																		
Dark dot	$N \leq 2$	$N \leq 2$																		
Total dot	$N \leq 2$	$N \leq 2$																		
Mura	Not visible through 5% ND filters.		Note 2																	

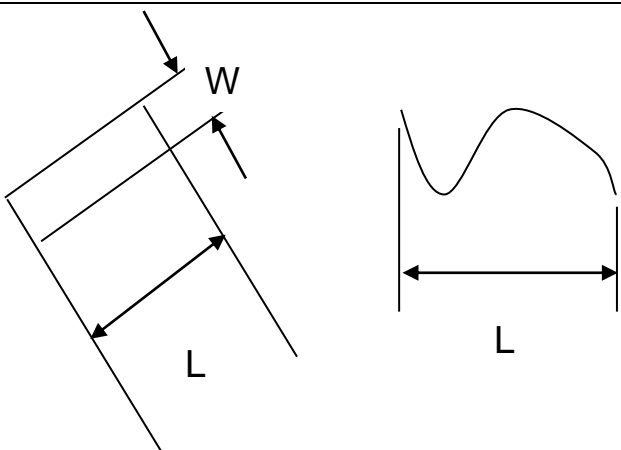
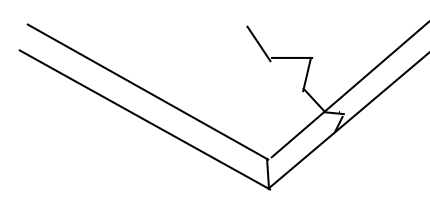
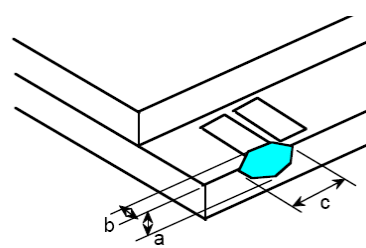
<p>03</p>	<p>Black and White line Scratch Foreign material (Line type) (Minor defect)</p>	 <table border="1" data-bbox="606 638 1236 952"> <thead> <tr> <th>Length</th> <th>Width</th> <th>Acc. Qty</th> </tr> </thead> <tbody> <tr> <td>/</td> <td>$W \leq 0.03$</td> <td>Ignore</td> </tr> <tr> <td>$L \leq 2.5$</td> <td>$0.03 < W \leq 0.05$</td> <td>3</td> </tr> <tr> <td>$L \leq 2.5$</td> <td>$0.05 < W \leq 0.10$</td> <td>2</td> </tr> <tr> <td>/</td> <td>$0.1 < W$</td> <td>0</td> </tr> <tr> <td colspan="2">Total</td> <td>3</td> </tr> </tbody> </table> <p>Distance between 2 defects should more than 3mm apart. Scratches not viewable through the back of the display are acceptable.</p>	Length	Width	Acc. Qty	/	$W \leq 0.03$	Ignore	$L \leq 2.5$	$0.03 < W \leq 0.05$	3	$L \leq 2.5$	$0.05 < W \leq 0.10$	2	/	$0.1 < W$	0	Total		3
Length	Width	Acc. Qty																		
/	$W \leq 0.03$	Ignore																		
$L \leq 2.5$	$0.03 < W \leq 0.05$	3																		
$L \leq 2.5$	$0.05 < W \leq 0.10$	2																		
/	$0.1 < W$	0																		
Total		3																		
<p>04</p>	<p>Glass Crack (Minor defect)</p>	 <p>Crack is potential to enlarge, any type is not allowed.</p>																		
<p>05</p>	<p>Glass Chipping Pad Area: (Minor defect)</p> 	<table border="1" data-bbox="845 1523 1324 1702"> <thead> <tr> <th>Length and Width</th> <th>Acc. Qty</th> </tr> </thead> <tbody> <tr> <td>$c > 3.0, b < 1.0$</td> <td>1</td> </tr> <tr> <td>$c < 3.0, b < 1.0$</td> <td>3</td> </tr> <tr> <td colspan="2">$a < \text{Glass Thickness}$</td> </tr> </tbody> </table>	Length and Width	Acc. Qty	$c > 3.0, b < 1.0$	1	$c < 3.0, b < 1.0$	3	$a < \text{Glass Thickness}$											
Length and Width	Acc. Qty																			
$c > 3.0, b < 1.0$	1																			
$c < 3.0, b < 1.0$	3																			
$a < \text{Glass Thickness}$																				

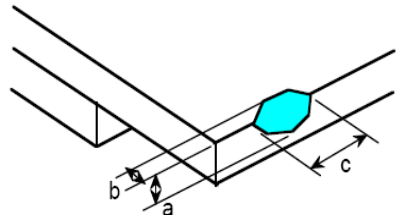
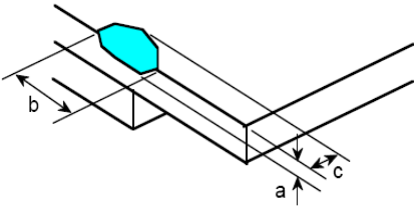
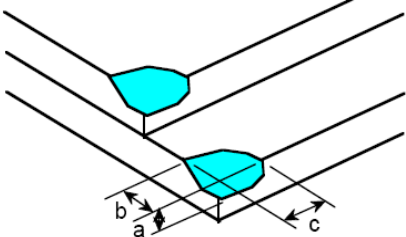
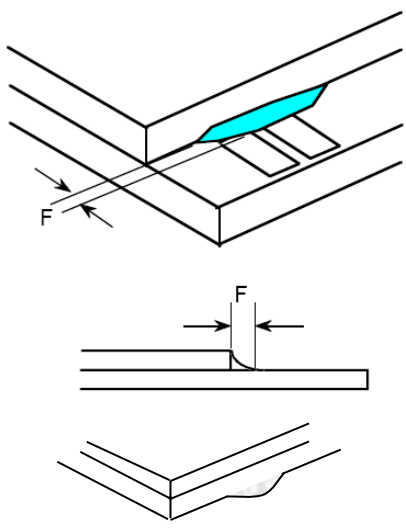
<p>06</p>	<p>Glass Chipping Rear of Pad Area: (Minor defect)</p> 	<table border="1"> <thead> <tr> <th>Length and Width</th> <th>Acc. Qty</th> </tr> </thead> <tbody> <tr> <td>$c > 3.0, b < 1.0$</td> <td>1</td> </tr> <tr> <td>$c < 3.0, b < 1.0$</td> <td>2</td> </tr> <tr> <td>$c < 3.0, b < 0.5$</td> <td>4</td> </tr> <tr> <td colspan="2" style="text-align: center;">$a < \text{Glass Thickness}$</td> </tr> </tbody> </table>	Length and Width	Acc. Qty	$c > 3.0, b < 1.0$	1	$c < 3.0, b < 1.0$	2	$c < 3.0, b < 0.5$	4	$a < \text{Glass Thickness}$	
Length and Width	Acc. Qty											
$c > 3.0, b < 1.0$	1											
$c < 3.0, b < 1.0$	2											
$c < 3.0, b < 0.5$	4											
$a < \text{Glass Thickness}$												
<p>07</p>	<p>Glass Chipping Except Pad Area: (Minor defect)</p> 	<table border="1"> <thead> <tr> <th>Length and Width</th> <th>Acc. Qty</th> </tr> </thead> <tbody> <tr> <td>$c > 3.0, b < 1.0$</td> <td>1</td> </tr> <tr> <td>$c < 3.0, b < 1.0$</td> <td>2</td> </tr> <tr> <td>$c < 3.0, b < 0.5$</td> <td>4</td> </tr> <tr> <td colspan="2" style="text-align: center;">$a < \text{Glass Thickness}$</td> </tr> </tbody> </table>	Length and Width	Acc. Qty	$c > 3.0, b < 1.0$	1	$c < 3.0, b < 1.0$	2	$c < 3.0, b < 0.5$	4	$a < \text{Glass Thickness}$	
Length and Width	Acc. Qty											
$c > 3.0, b < 1.0$	1											
$c < 3.0, b < 1.0$	2											
$c < 3.0, b < 0.5$	4											
$a < \text{Glass Thickness}$												
<p>08</p>	<p>Glass Corner Chipping: (Minor defect)</p> 	<table border="1"> <thead> <tr> <th>Length and Width</th> <th>Acc. Qty</th> </tr> </thead> <tbody> <tr> <td>$c < 3.0, b < 3.0$</td> <td>Ignore</td> </tr> <tr> <td colspan="2" style="text-align: center;">$a < \text{Glass Thickness}$</td> </tr> </tbody> </table>	Length and Width	Acc. Qty	$c < 3.0, b < 3.0$	Ignore	$a < \text{Glass Thickness}$					
Length and Width	Acc. Qty											
$c < 3.0, b < 3.0$	Ignore											
$a < \text{Glass Thickness}$												
<p>09</p>	<p>Glass Burr: (Minor defect)</p> 	<table border="1"> <thead> <tr> <th>Length</th> <th>Acc. Qty</th> </tr> </thead> <tbody> <tr> <td>$F < 1.0$</td> <td>Ignore</td> </tr> </tbody> </table> <p>Glass burr don't affect assemble and module dimension.</p>	Length	Acc. Qty	$F < 1.0$	Ignore						
Length	Acc. Qty											
$F < 1.0$	Ignore											

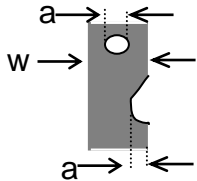
10	<p>FPC Defect: (Minor defect)</p> 	<p>10.1 Dent, pinhole width $a < w/3$. (w: circuitry width.)</p> <p>10.2 Open circuit is unacceptable.</p> <p>10.3 No oxidation, contamination and distortion.</p>										
11	Bubble on Polarizer (Minor defect)	<table border="1"> <thead> <tr> <th>Diameter</th> <th>Acc. Qty</th> </tr> </thead> <tbody> <tr> <td>$\varphi \leq 0.20$</td> <td>Ignore</td> </tr> <tr> <td>$0.20 < \varphi \leq 0.30$</td> <td>4</td> </tr> <tr> <td>$0.30 < \varphi \leq 0.50$</td> <td>1</td> </tr> <tr> <td>$0.50 < \varphi$</td> <td>None</td> </tr> </tbody> </table>	Diameter	Acc. Qty	$\varphi \leq 0.20$	Ignore	$0.20 < \varphi \leq 0.30$	4	$0.30 < \varphi \leq 0.50$	1	$0.50 < \varphi$	None
Diameter	Acc. Qty											
$\varphi \leq 0.20$	Ignore											
$0.20 < \varphi \leq 0.30$	4											
$0.30 < \varphi \leq 0.50$	1											
$0.50 < \varphi$	None											
12	Dent on Polarizer (Minor defect)	<table border="1"> <thead> <tr> <th>Diameter</th> <th>Acc. Qty</th> </tr> </thead> <tbody> <tr> <td>$\varphi \leq 0.20$</td> <td>Ignore</td> </tr> <tr> <td>$0.20 < \varphi \leq 0.30$</td> <td>4</td> </tr> <tr> <td>$0.30 < \varphi \leq 0.50$</td> <td>1</td> </tr> <tr> <td>$0.50 < \varphi$</td> <td>None</td> </tr> </tbody> </table>	Diameter	Acc. Qty	$\varphi \leq 0.20$	Ignore	$0.20 < \varphi \leq 0.30$	4	$0.30 < \varphi \leq 0.50$	1	$0.50 < \varphi$	None
Diameter	Acc. Qty											
$\varphi \leq 0.20$	Ignore											
$0.20 < \varphi \leq 0.30$	4											
$0.30 < \varphi \leq 0.50$	1											
$0.50 < \varphi$	None											
13	Bezel	<p>13.1 No rust, distortion on the Bezel.</p> <p>13.2 No visible fingerprints, stains or other contamination.</p>										
14	PCB	<p>14.1 No distortion or contamination on PCB terminals.</p> <p>14.2 All components on PCB must same as documented on the BOM/component layout.</p> <p>14.3 Follow IPC-A-600F.</p>										
15	Soldering	Follow IPC-A-610C standard										
16	Electrical Defect (Major defect)	<p>The below defects must be rejected.</p> <p>16.1 Missing vertical / horizontal segment,</p> <p>16.2 Abnormal Display.</p> <p>16.3 No function or no display.</p> <p>16.4 Current exceeds product specifications.</p> <p>16.5 LCD viewing angle defect.</p> <p>16.6 No Backlight.</p> <p>16.7 Dark Backlight.</p> <p>16.8 Touch Panel no function.</p>										

Remark: LCD Panel Broken shall be rejected. Defect out of LCD viewing area is acceptable.

Inspection Specification for the Capacitive Touch Panel

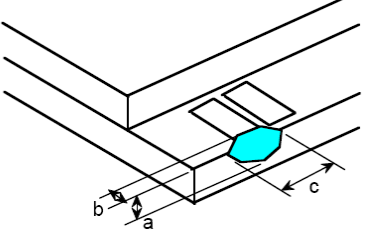
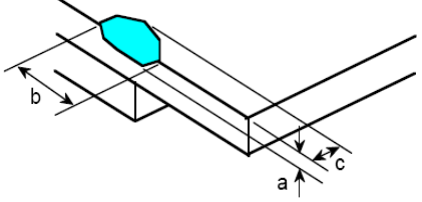
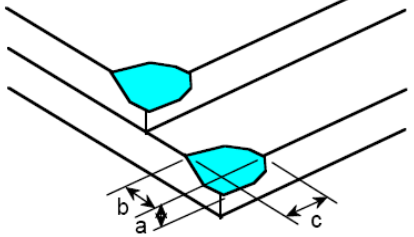
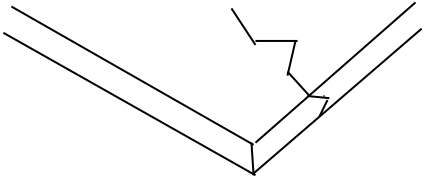
<p>01</p>	<p>Chipping Pad Area(Not include the cover lens): (Minor defect)</p> 	<p>The chip is seriously influence the product's function, any type is not allowed.</p>						
<p>02</p>	<p>Chipping Except Pad Area(Not include the cover lens): (Minor defect)</p> 	<table border="1" data-bbox="880 763 1353 893"> <thead> <tr> <th>Length and Width</th> <th>Acc. Qty</th> </tr> </thead> <tbody> <tr> <td>$c < 1.5, b < 1$</td> <td>$N \leq 5$</td> </tr> <tr> <td colspan="2">$a < 1/2$ Glass Thickness</td> </tr> </tbody> </table>	Length and Width	Acc. Qty	$c < 1.5, b < 1$	$N \leq 5$	$a < 1/2$ Glass Thickness	
Length and Width	Acc. Qty							
$c < 1.5, b < 1$	$N \leq 5$							
$a < 1/2$ Glass Thickness								
<p>03</p>	<p>Corner Chipping(Not include the cover lens): (Minor defect)</p> 	<table border="1" data-bbox="880 1137 1353 1267"> <thead> <tr> <th>Length and Width</th> <th>Acc. Qty</th> </tr> </thead> <tbody> <tr> <td>$c < 1.5, b < 0.5$</td> <td>Ignore</td> </tr> <tr> <td colspan="2">$a < 1/2$ Glass Thickness</td> </tr> </tbody> </table>	Length and Width	Acc. Qty	$c < 1.5, b < 0.5$	Ignore	$a < 1/2$ Glass Thickness	
Length and Width	Acc. Qty							
$c < 1.5, b < 0.5$	Ignore							
$a < 1/2$ Glass Thickness								
<p>04</p>	<p>Crack: (Minor defect)</p>	 <p>Crack is potential to enlarge, any type is not allowed.</p>						
<p>05</p>	<p>Cover lens must be without any chips, cracks or other damage when viewed from the front.</p>							

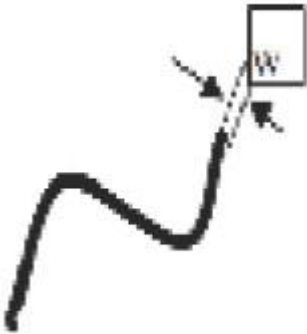
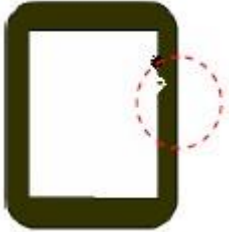
<p>06</p>	<p>Same/Different color spot</p> 	<p>D: Diameter W: width L: length</p> <table border="1" data-bbox="890 230 1342 365"> <thead> <tr> <th>Diameter</th> <th>Acc. Qty</th> </tr> </thead> <tbody> <tr> <td>D < 0.20</td> <td>Ignore</td> </tr> </tbody> </table> <p>Active Area:</p> <table border="1" data-bbox="890 412 1342 631"> <thead> <tr> <th>Diameter</th> <th>Acc. Qty</th> </tr> </thead> <tbody> <tr> <td>0.20 < D ≤ 0.30</td> <td>2</td> </tr> <tr> <td>0.30 < D ≤ 0.50</td> <td>1</td> </tr> <tr> <td>D>0.5</td> <td>NG</td> </tr> </tbody> </table> <p>Viewing Area :</p> <table border="1" data-bbox="890 678 1342 916"> <thead> <tr> <th>Diameter</th> <th>Acc. Qty</th> </tr> </thead> <tbody> <tr> <td>D<0.20</td> <td>Ignore</td> </tr> <tr> <td>0.20 < D ≤ 0.5</td> <td>3</td> </tr> <tr> <td>D>0.5</td> <td>NG</td> </tr> </tbody> </table> <p>Distance between 2 defects should more than 15mm apart.</p>	Diameter	Acc. Qty	D < 0.20	Ignore	Diameter	Acc. Qty	0.20 < D ≤ 0.30	2	0.30 < D ≤ 0.50	1	D>0.5	NG	Diameter	Acc. Qty	D<0.20	Ignore	0.20 < D ≤ 0.5	3	D>0.5	NG
Diameter	Acc. Qty																					
D < 0.20	Ignore																					
Diameter	Acc. Qty																					
0.20 < D ≤ 0.30	2																					
0.30 < D ≤ 0.50	1																					
D>0.5	NG																					
Diameter	Acc. Qty																					
D<0.20	Ignore																					
0.20 < D ≤ 0.5	3																					
D>0.5	NG																					
<p>07</p>	<p>Cover lens line Scratch</p> 	<table border="1" data-bbox="794 1061 1422 1368"> <thead> <tr> <th>Length</th> <th>Width</th> <th>Acc. Qty</th> </tr> </thead> <tbody> <tr> <td>/</td> <td>W ≤ 0.08mm</td> <td>Ignore</td> </tr> <tr> <td>L ≤ 5</td> <td>0.08 < W ≤ 0.15</td> <td>2</td> </tr> <tr> <td>L ≤ 3</td> <td>0.15 < W ≤ 0.20</td> <td>1</td> </tr> <tr> <td>-</td> <td>W>0.2</td> <td>NG</td> </tr> <tr> <td>L>5</td> <td>-</td> <td>NG</td> </tr> </tbody> </table> <p>Distance between 2 defects should more than 15mm apart.</p>	Length	Width	Acc. Qty	/	W ≤ 0.08mm	Ignore	L ≤ 5	0.08 < W ≤ 0.15	2	L ≤ 3	0.15 < W ≤ 0.20	1	-	W>0.2	NG	L>5	-	NG		
Length	Width	Acc. Qty																				
/	W ≤ 0.08mm	Ignore																				
L ≤ 5	0.08 < W ≤ 0.15	2																				
L ≤ 3	0.15 < W ≤ 0.20	1																				
-	W>0.2	NG																				
L>5	-	NG																				
<p>08</p>	<p>Printing sawtooth</p> 	<table border="1" data-bbox="794 1576 1422 1796"> <thead> <tr> <th>Length</th> <th>Width</th> <th>Acc. Qty</th> </tr> </thead> <tbody> <tr> <td>/</td> <td>W ≤ 0.2mm</td> <td>2</td> </tr> <tr> <td>L ≤ 2</td> <td>0.2 < W ≤ 0.3</td> <td>1</td> </tr> <tr> <td>L ≤ 2</td> <td>W>0.3</td> <td>NG</td> </tr> </tbody> </table>	Length	Width	Acc. Qty	/	W ≤ 0.2mm	2	L ≤ 2	0.2 < W ≤ 0.3	1	L ≤ 2	W>0.3	NG								
Length	Width	Acc. Qty																				
/	W ≤ 0.2mm	2																				
L ≤ 2	0.2 < W ≤ 0.3	1																				
L ≤ 2	W>0.3	NG																				

11.7. Classification of Defects

11.7.1 Visual defects (Except no / wrong label) are treated as minor defect and electrical defect is major.

11.7.2 Two minor defects are equal to one major in lot sampling inspection.

11.8. Identification/marketing criteria

Any unit with illegible / wrong /double or no marking/ label shall be rejected.

11.9. Packaging

11.9.1 There should be no damage of the outside carton box, each packaging box should have one identical label.

11.9.2 Modules inside package box should have compliant mark.

11.9.3 All direct package materials shall offer ESD protection

Note1: Bright dot is defined as the defective area of the dot is larger than 50% of one sub-pixel area.

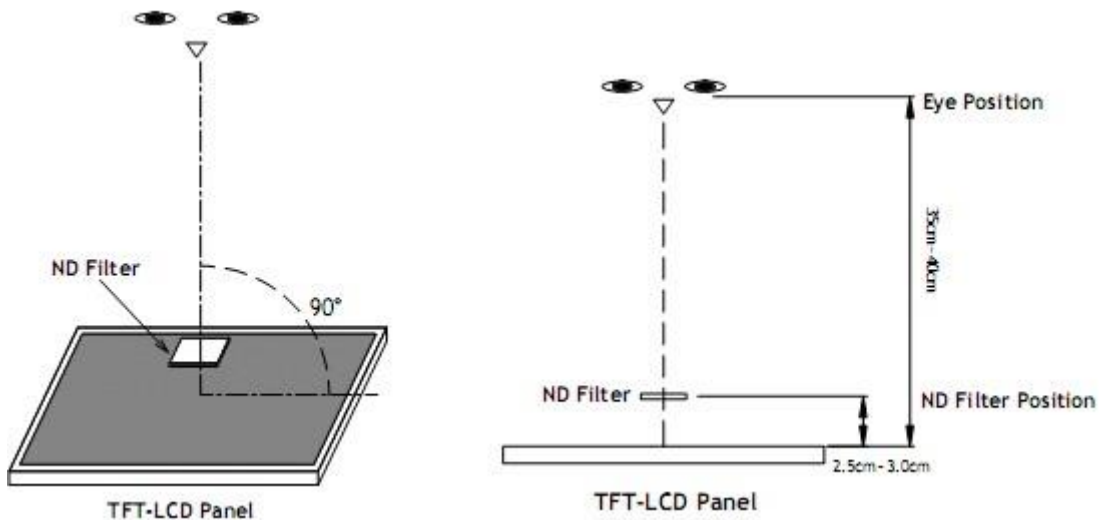

Bright dot: The bright dot size defect at black display pattern. It can be recognized by 2% transparency of filter when the distance between eyes and panel is 350mm ± 50mm.

Dark dot: Cyan, Magenta or Yellow dot size defect at white display pattern. It can be recognized by 5% transparency of filter when the distance between eyes and panel is 350mm ± 50mm.

Note2: Mura on display which appears darker / brighter against background brightness on parts of display area.

12. Reliability Specification

No	Item	Condition	Quantity	Criteria
1	High Temperature Operating	+70°C, 96Hrs	2	GB/T2423.2-2008
2	Low Temperature Operating	-20°C, 96Hrs	2	GB/T2423.1-2008
3	High Humidity Storage	+50°C, 90%RH, 96Hrs	2	GB/T2423.3-2016
4	High Temperature Storage	+80°C, 96Hrs	2	GB/T2423.2-2008
5	Low Temperature Storage	-30°C, 96Hrs	2	GB/T2423.1-2008
6	Thermal Cycling Test Storage	-20°C, 60min~+70°C, 60min, 20 cycles.	2	GB/T2423.22-2012
7	Packing vibration	Frequency range:10Hz~50Hz Acceleration of gravity:5G X, Y, Z 30 min for each direction.	-	GB/T5170.14-2009
8	Electrical Static Discharge	Air: ±8kV 150pF/330 Ω 5 times Contact: ±4kV 150pF/330 Ω 5 times	2	GB/T17626.2-2018
9	Drop Test (Packaged)	Height:80 cm,1 corner, 3 edges, 6 surfaces.	-	GB/T2423.8-1995

Note1. No deflection cosmetic and operational function allowable.

Note2. Total current Consumption should be below double of initial value

13. Precautions and Warranty

13.1. Safety

- 13.1.1. The liquid crystal in the LCD is poisonous. Do not put it in your mouth. If the liquid crystal touches your skin or clothes, wash it off immediately using soap and water.
- 13.1.2. Since the liquid crystal cells are made of glass, do not apply strong impact on them. Handle with care.

13.2. Handling

- 13.2.1. Reverse and use within ratings in order to keep performance and prevent damage.
- 13.2.2. Do not wipe the polarizer with dry cloth, as it might cause scratch. If the surface of the LCD needs to be cleaned, wipe it swiftly with cotton or other soft cloth soaked with petroleum IPA, do not use other chemicals.

13.3. Storage

- 13.3.1 Do not store the LCD module beyond the specified temperature ranges.
- 13.3.2 Strong light exposure causes degradation of polarizer and color filter.

13.4. Metal Pin (Apply to Products with Metal Pins)

13.4.1. Pins of LCD and Backlight

- 13.4.1.1. Solder tip can touch and press on the tip of Pin LEAD during the soldering

13.4.1.2. Recommended Soldering Conditions

Solder Type: Sn96.3~94-Ag3.3~4.3-Cu0.4~1.1

Maximum Solder Temperature: 370°C

Maximum Solder Time: 3s at the maximum temperature

Recommended Soldering Temp: 350±20°C

Typical Soldering Time: ≤3s

13.4.1.3. Solder Wetting

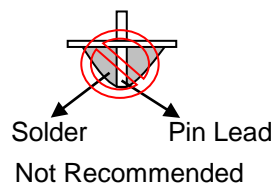
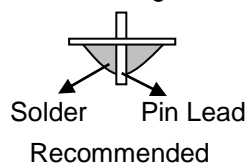

13.4.2. Pins of EL

- 13.4.2.1. Solder tip can touch and press on the tip of EL leads during soldering.
- 13.4.2.2. No Solder Paste on the soldering pad on the motherboard is recommended.

13.4.2.3. Recommended Soldering Conditions

Solder type: Nippon Alimit Leadfree SR-34, size 0.5mm

Recommended Solder Temperature: 270~290°C

Typical Soldering Time: ≤2s

Minimum solder distance from EL lamp (body):2.0mm

- 13.4.2.4. No horizontal press on the EL leads during soldering.

- 13.4.2.5. 180° bend EL leads three times is not allowed.

13.4.2.6. Solder Wetting

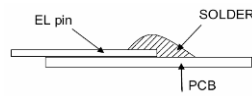

Recommended

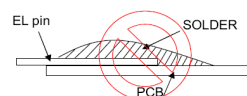

Not Recommended

13.4.2.7. The type of the solder iron:

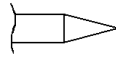

Recommended

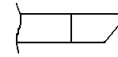

Not Recommended

13.4.2.8. Solder Pad

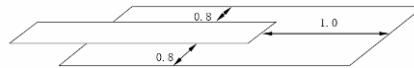

13.5. Operation

- 13.5.1. Do not drive LCD with DC voltage
- 13.5.2. Response time will increase below lower temperature
- 13.5.3. Display may change color with different temperature
- 13.5.4. Mechanical disturbance during operation, such as pressing on the display area, may cause the segments to appear “fractured”.
- 13.5.5. Do not connect or disconnect the LCM to or from the system when power is on.
- 13.5.6. Never use the LCM under abnormal condition of high temperature and high humidity.
- 13.5.7. Module has high frequency circuits. Sufficient suppression to the electromagnetic interface shall be done by system manufacturers. Grounding and shielding methods may be important to minimize the interference.

Do not display the fixed pattern for long time (we suggest the time not longer than one hour) because it may develop image sticking due to the TFT structure.

13.6. Static Electricity

- 13.6.1. CMOS LSIs are equipped in this unit, so care must be taken to avoid the electro-static charge, by ground human body, etc.
- 13.6.2. The normal static prevention measures should be observed for work clothes and benches.
- 13.6.3. The module should be kept into anti-static bags or other containers resistant to static for storage.

13.7. Limited Warranty

- 13.7.1. Our warranty liability is limited to repair and/or replacement. We will not be responsible for any consequential loss.
- 13.7.2. If possible, we suggest customer to use up all modules in six months. If the module storage time over twelve months, we suggest that recheck it before the module be used.
- 13.7.3. After the product shipped, any product quality issues must be feedback within three months, otherwise, we will not be responsible for the subsequent or consequential events.

14. Outline Drawing

